

**AMENDMENT NO. 1
TO
RIVERSIDE COUNTY TRANSPORTATION COMMISSION
COMPREHENSIVE LICENSE AGREEMENT WITH CITY OF PERRIS
FOR RAILROAD TRACKS AND OTHER IMPROVEMENTS**

1. Parties and Date.

This AMENDMENT NO. 1 TO COMPREHENSIVE LICENSE AGREEMENT WITH CITY OF PERRIS FOR RAILROAD TRACKS AND OTHER IMPROVEMENTS ("Amendment") is made this ___ day of _____ 2015 ("Effective Date") by and between the RIVERSIDE COUNTY TRANSPORTATION COMMISSION, a California public agency (referred to herein as "COMMISSION") and THE CITY OF PERRIS, a municipal corporation and general law city (referred to herein as "CITY"). COMMISSION and CITY are sometimes referred to individually as "Party" and collectively as "Parties."

2. Recitals.

2.1 The Parties have executed a Comprehensive License Agreement for Railroad Tracks and Other Improvements dated March 7, 2013 (the "Master Agreement").

2.2 The Master Agreement sets forth a description of the property licensed thereunder, referred to as the "Licensed Property", which includes certain property referred to as the "Perris Depot property", both as further defined in the Master Agreement.

2.3 The Parties have agreed to include additional property owned by COMMISSION within the definition of the Perris Depot property, and therefor within the Licensed Property.

2.4 The Parties desire to enter into this Amendment for the purpose of amending Exhibits "B" and "C" of the Master Agreement related to the Perris Depot property to reflect the additional property included as part of the Licensed Property.

2.5 The Master Agreement also provides that COMMISSION intends to convey that property described as the "Museum Line property" to the CITY. Until such time as the conveyance has been completed, including approval thereof by BNSF, the Parties desire to include the Museum Line Property under the license granted pursuant to the Master Agreement. Upon completion of the conveyance and recordation of a quitclaim deed or other document transferring the Museum Line Property to CITY, the Museum Line Property shall automatically be removed from the Licensed Property without any further amendment of the Master Agreement or action by COMMISSION or CITY, as described in Section 3.5 below.

NOW, THEREFORE, for and in consideration of the mutual covenants and conditions hereinafter stated, the Parties agree as follows:

3. Terms.

3.1 Exhibit "B" and Exhibit "C" of the Master Agreement related to the Perris Depot property are hereby replaced in their entirety by the versions of Exhibit "B" and Exhibit "C" attached to this Amendment and incorporated herein by reference.

3.2 Section 3.3 of the Master Agreement is hereby amended and replaced in its entirety with the following:

3.3 **Licensed Property.** The term "Licensed Property" means and refers to, collectively, that portion of the COMMISSION's property further described and defined herein as the Perris Depot property, the New Track property, and the Museum Line property, and licensed to CITY pursuant to the terms of this Agreement.

3.3 Section 3.5 of the Master Agreement is hereby amended and replaced in its entirety with the following:

3.5 **Museum Line property.** The term "Museum Line property" means and refers to that certain rail right of way, including existing railroad track, railroad crossings and other improvements and appurtenances, in the City of Perris, Riverside County, California generally located south of 7th Street to Mapes Road, and more specifically depicted in Exhibit "A".

3.4 The Master Agreement shall be amended to include a new Section 5.1.6 to read as follows:

5.1.6 Grant of License for Use of Museum Line Property. Subject to the terms and conditions hereinafter set forth, COMMISSION hereby grants to CITY a license in, on, over, and across the Museum Line property for use, repair and maintenance of the railroad tracks and related improvements on and across the Museum Line property, and for no other purpose.

Subject to the terms and conditions hereinafter set forth, COMMISSION and CITY agree that CITY shall have the right to assign or sublicense the rights of occupancy granted to CITY related to the Museum Line Property to MUSEUM for the limited purposes of allowing the MUSEUM to use, repair and maintain the property, to operate Trains on the Museum Line property, without limitation on days or hours of such operation, as part of the Museum operations, and for other MUSEUM uses and operations. No operation of Trains on the Museum Line property shall be permitted until evidence of adequate insurance has been provided to COMMISSION, as required herein.

3.5 The Master Agreement shall be amended to include a new Section 5.1.7 to read as follows:

5.1.7 Conveyance of Museum Line Property. Upon recordation of a quitclaim deed or other conveyance document conveying the Museum Line property from COMMISSION to CITY, the Museum Line property shall no longer be part of the Licensed Property and Section 5.1.6 shall be of no further force and effect. The conveyance of the Museum Line property shall be subject to the terms and conditions of the quitclaim deed or other conveyance document. Subject to BNSF's approval of the conveyance, COMMISSION's Executive Director and CITY's City Manager are hereby authorized to execute the quitclaim deed or other conveyance document without further action by COMMISSION or CITY.

3.6 The recitals set forth above are true and correct and are incorporated into this Amendment by reference as though fully set forth herein.

3.7 Except as set forth herein, all provisions of the Master Agreement shall remain in full force and effect and shall govern the actions of the Parties and the amended provisions set forth in this Amendment.

[Signatures on following page]

**SIGNATURE PAGE
TO
AMENDMENT NO. 1 TO
RIVERSIDE COUNTY TRANSPORTATION COMMISSION
COMPREHENSIVE LICENSE AGREEMENT WITH CITY OF PERRIS
FOR RAILROAD TRACKS AND OTHER IMPROVEMENTS**

IN WITNESS WHEREOF, the parties have executed this Agreement No. 13-33-082-01 in duplicate the day and year first above written.

**RIVERSIDE COUNTY
TRANSPORTATION COMMISSION**

CITY OF PERRIS

By: _____
Anne Mayer, Executive Director

By: _____
Richard Belmudez, City Manager

APPROVED AS TO FORM:

ATTEST:

By: _____
Best Best & Krieger LLP
Counsel to the Riverside
County Transportation
Commission

By: _____
Nancy Salazar, City Clerk

APPROVED AS TO FORM:

By: _____
Aleshire & Wynder, LLP
Eric L. Dunn, City Attorney

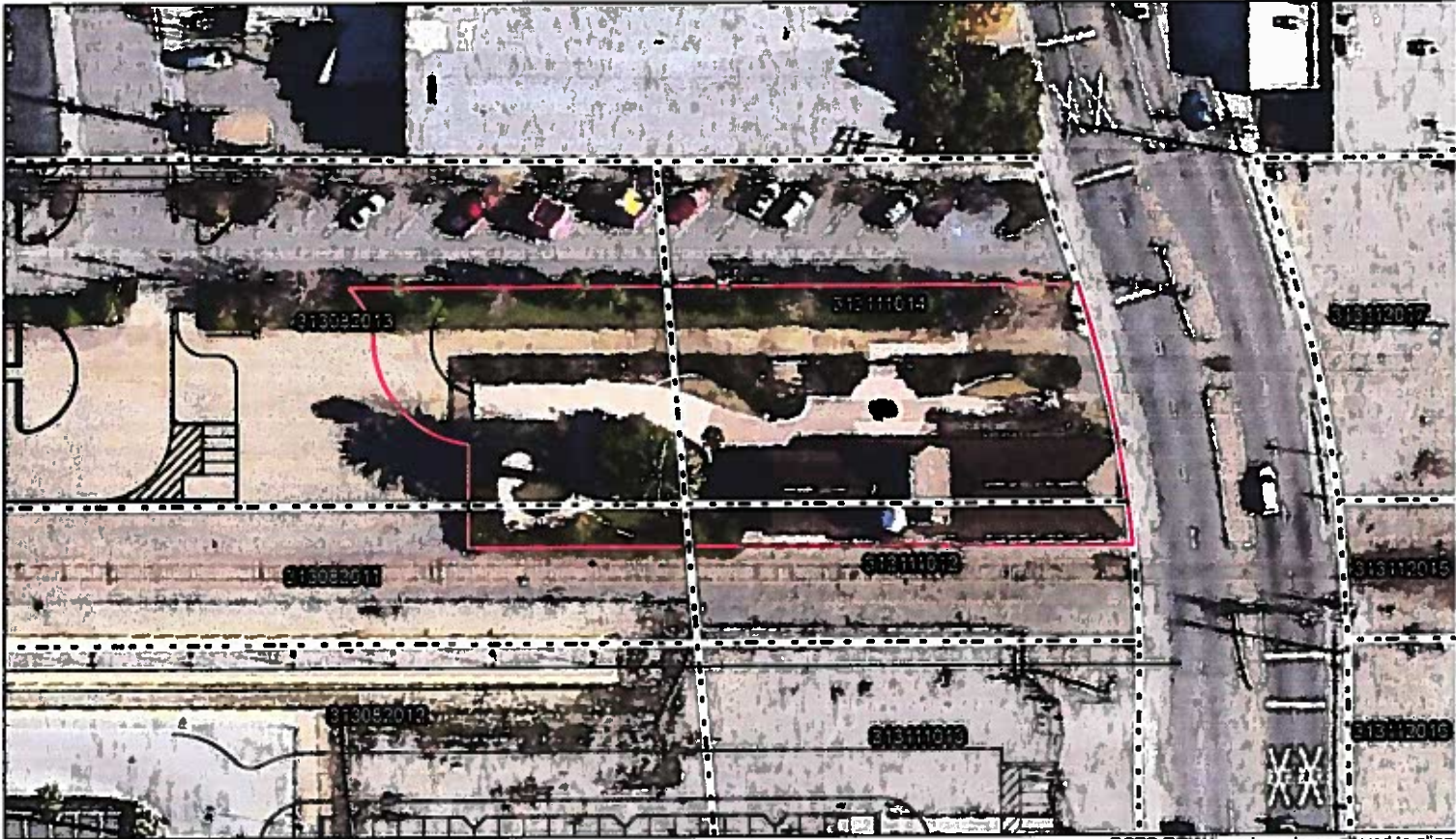

 Perris Depot/Landscape



EXHIBIT A
 PERRIS, CALIFORNIA
 AGREEMENT NO. 13-33-082-01

0 25 50 Feet

RCTC ROW lines have been altered to align with the aerial imagery for visualization purposes only
 Parcel boundary data by RCTLMA
 Parking data by J.L. PATTERSON & ASSOCIATES, INC
 Aerial imagery by GOOGLE EARTH
 Date of Imagery: 11/6/2012
 Version 4 Date: 9/11/2014

Epic Land Solutions, Inc.

This map was created using the best data available at the time of production. Epic Land Solutions Inc. assumes no responsibility for the accuracy of third party information. This map is intended for data visualization only and should not serve as the basis for any legal action or be used for engineering purposes.

EXHIBIT "B"
DEPICTION OF THE PERRIS DEPOT PROPERTY

[Attached behind this page]

EXHIBIT C
DESCRIPTION OF THE PERRIS DEPOT

Historic Depot Building on Perris Depot property, landscape improvements and driveway entrance.

**RECORDING REQUESTED BY AND
WHEN RECORDED RETURN TO:**

Riverside County Transportation Commission
4080 Lemon Street, 3rd Floor
Riverside, CA 92502-2208
Attn: Executive Director

Exempt from Recording Fee
Pursuant to Government Code Section 27383

Exempt from Documentary Transfer Tax
Pursuant to R&T Code § 11922

OPTION TO PURCHASE AGREEMENT

THIS OPTION TO PURCHASE AGREEMENT ("Agreement") is made as of _____, 2015 ("Agreement Date"), by and between the RIVERSIDE COUNTY TRANSPORTATION COMMISSION, a county transportation commission ("Optionee") and the CITY OF PERRIS, a California municipal corporation ("Optionor"). Optionor and Optionee may be referred to herein individually as a "Party" or collectively as the "Parties."

RECITALS

1. Optionee owns in fee that certain real property, including the existing railroad track, in the City of Perris, Riverside County, California generally located south of 7th Street to Mapes Road, commonly known as the Near Perris (Old Elsinore Museum Line) (the "Property"), as more fully described in the legal description attached as Exhibit "A" and depicted in the attached Exhibit "B", both incorporated herein by reference.
2. The Property was subject to that certain lease agreement originally entered into by the Atchison, Topeka and Santa Fe Railway Company ("Santa Fe") and the Orange Empire Railway Museum ("OERM") dated February 12, 1979, as subsequently amended (Secretary's Contract No. 157248, as amended) ("Lease"), which was assumed by Optionee upon transfer of the Property from Santa Fe to Optionee.
3. Optionor and Optionee have entered into that certain Comprehensive License Agreement ("License") to provide for the conveyance of the Property to Optionor and the licensing to Optionor of certain property referred to in the License as the "Perris Depot Property." The Perris Depot Property is adjacent to the Property, and both the Property and the Perris Depot Property properties have been used by OERM for the purpose of conducting museum train movements, both with and without passengers.
4. Pursuant to that certain Quitclaim Deed Containing Covenants and Restrictions Including a Power of Termination, dated of even date herewith ("Quitclaim Deed"), Optionee will convey the Property to Optionor, for continuation of its current use as made by OERM as provided in the License and Quitclaim Deed, subject to certain restrictions and conditions, including a power of termination as set forth therein.

5. In connection with the conveyance to be made under the Quitclaim Deed, and as material consideration therefor, Optionee has negotiated the exclusive right and option ("Option") to purchase the Property or a portion thereof ("Option Property") from Optionor at such future date, if any, as Optionee requires the Property for the purpose of providing commuter rail service.
6. Upon its exercise of the Option, Optionee shall pay the agreed Purchase Price for the Option Property, as set forth herein, and Optionee shall not be required to pay additional consideration for the Option Property.
7. In light of the foregoing, Optionor herein grants an option to Optionee to purchase the Option Property as more particularly set forth herein.

OPTION AGREEMENT

NOW, THEREFORE, in consideration of the foregoing and for other good and valuable consideration, the receipt and adequacy of which are hereby acknowledged, the Parties agree as follows:

A. Grant of Option. In consideration of Optionee's agreement to convey the Property to Optionor pursuant to the Quitclaim Deed, Optionor hereby grants to Optionee the Option to purchase the Option Property, which shall be exercisable by Optionee in the manner and on the terms and conditions set forth in this Agreement. If not previously exercised, the term of the Option ("Option Term") shall expire eighty (80) years after the Agreement Date.

B. Exercise of Option. Optionee shall exercise the Option, if at all, by giving ninety (90) calendar days written notice to Optioner during the Option Term that Optionee requires the Option Property for commuter rail or related purposes ("Exercise Notice"). The Exercise Notice shall be accompanied by the Purchase Price described in Section C below. The Exercise Notice shall specify the proposed use of the Option Property. Optionee's timely delivery of the Exercise Notice and the Purchase Price to Optionor shall create a binding contract for the purchase and sale of the Option Property. Optionee shall not be entitled to exercise the Option for seven (7) years commencing as of the Agreement Date, or five (5) years after the date of completion of the New Track (as defined in the License), whichever is earlier.

C. Purchase Price and Closing Costs. The purchase price, including any applicable closing costs, for the Option Property ("Purchase Price") shall be One Dollar (\$1.00). Optionee shall pay any applicable escrow fees, and any other closing costs.

D. Conveyance. Upon Optionee's timely exercise of the Option, Optionor or its successors or assigns shall, at Optioner's sole expense, remove from title to the Option Property, prior to the closing date, all encumbrances not existing as of the date of the Quitclaim Deed (including without limitation any monetary liens) and shall thereafter convey by quitclaim deed to Optionee title to the Option Property, as specified in the Exercise Notice, and all improvements thereon. Such conveyance shall be duly acknowledged by Optionor, or its successors or assigns and a notary in a manner suitable for recordation. Optionee may enforce its rights pursuant to this Agreement by means of an action filed in any court of competent jurisdiction. Any improvements remaining on the Option Property following conveyance of the

Option Property from Optionor to Optionee, shall become the property of Optionee without further compensation to Optionor.

E. Operation of Property During Option Term. During the period commencing on the Agreement Date and ending on the earlier to occur of (a) the recording of the grant deed conveying the Option Property to Optionee or (b) the expiration of the Option:

1. Maintenance. Optionor shall maintain the Option Property in as good condition and state of repair as that existing on the Agreement Date (ordinary wear and tear excepted) in compliance with applicable law.

2. No Alteration. Except as authorized in the License or the Quitclaim Deed, Optionor shall not materially alter the physical condition of the Option Property, or introduce or release, or permit the introduction or release, in, from, under or on the Property of any substance or material that is described as a toxic or hazardous substance, waste or material or a pollutant or contaminant, or words of similar import, under applicable Federal, state or local laws and regulations.

F. Expiration Without Exercise; Unenforceability of Option. Should the Option expire without being exercised or be deemed unenforceable by a court of competent jurisdiction Optionor shall reasonably cooperate with Optionee to execute and acknowledge an instrument providing Optionee an easement for Optionee's use of the Option Property for commuter rail service. This Section F shall survive the termination or expiration of this Agreement.

G. Miscellaneous.

1. Brokerage Commissions. Each Party warrants and represents to the other that no broker, finder or other intermediary hired or employed by it is entitled to a commission, finder's fee or other compensation based upon the transaction contemplated hereby for which the other Party may become financially responsible and each Party shall indemnify and hold harmless the other Party from and against any and all claims, liabilities, losses, damages, costs and expenses (including, but not limited to, reasonable attorneys' fees, court costs and litigation expenses) caused by or arising out of the claim of any broker, finder or other intermediary alleging to have been employed or hired by the indemnitor, to a commission, finder's fee or other compensation based upon the transaction contemplated hereby. The obligations of Optionor and Optionee pursuant to this Section shall survive any termination of this Agreement.

2. Notices. Any notice hereunder to be given by Optionee to Optionor shall be deemed to be properly served on the date it is deposited in the United States Mail, postage prepaid, addressed to City Manager, City of Perris, 101 North "D" Street, Perris, California 92570. Any notice to be given hereunder by Optionor to Optionee shall be deemed to be properly served on the date it is deposited in the United States Mail, postage prepaid, addressed to Executive Director, Riverside County Transportation Commission, 4080 Lemon Street, Third Floor, Riverside, CA 92502-2208. Either Optionor or Optionee may change its address for the receipt of notice by giving written notice thereof to the other party of such change.

3. Time of the Essence. Time is of the essence of this Agreement and each and every term and provision hereof.

4. **California Law.** This Agreement shall be governed by and construed in accordance with the internal laws of the State of California applicable to agreements made and to be performed within the state.

5. **Interpretation.** This Agreement has been negotiated at arm's length between the Parties. Accordingly, any rule of law (including California Civil Code Section 1654) or legal decision that would require interpretation of any ambiguities in this Agreement against the party that has drafted it is not applicable and is waived. The provisions of this Agreement shall be interpreted in a reasonable manner to effect the purpose of the Parties and this Agreement.

6. **Severability.** If any provision of this Agreement, or the application thereof, shall for any reason and to any extent be invalid or unenforceable, the remainder of this Agreement and application of such provision to other circumstances, shall be interpreted so as best to reasonably effect the intent of the Parties hereto.

7. **Performance of Acts on Business Days.** Unless specifically stated to the contrary, all references to days herein shall be deemed to refer to calendar days. In the event that the final date for payment of any amount or performance of any act hereunder falls on a Saturday, Sunday or holiday, such payment may be made or act performed on the next succeeding business day.

8. **Venue; Jurisdiction.** The Parties hereto agree that the State Courts located in Riverside County, California ("Court") shall have exclusive jurisdiction over any action or proceeding brought to enforce or interpret any provision of this Agreement or otherwise arising out of the transaction described herein ("Action"), and the Parties hereby consent to the exercise of personal jurisdiction over them by the Court for purposes of resolving the Action. Either Party may file a complaint with the Court, and in no other court.

9. **Attorneys' Fees.** In the event of any Action instituted between Optionor or Optionee in connection with this Agreement, the prevailing Party shall be entitled to recover from the losing Party all of its costs and expenses, including, without limitation, court costs, all costs of appeals and reasonable attorneys' fees.

10. **Further Assurances; Survival.** Subject to the terms and conditions hereof, the Parties agree to cooperate with each other and to perform such further acts or execute and deliver such additional instruments or documents as any Party may reasonably request in order to carry out the purposes of this Agreement and the transactions contemplated hereby. All covenants and obligations contained in this Agreement which imply or require performance after the conveyance of the Option Property date shall survive such conveyance.

11. **Entire Agreement; Amendments.** This Agreement is intended by the Parties to be the final expression of their agreement with respect to the subject matter hereof, and is intended as the complete and exclusive statement of the terms of the agreement between the Parties. As such, this Agreement supersedes any prior understandings between the Parties, whether oral or written. Any amendments to this Agreement shall be in writing and shall be signed by all Parties hereto.

12. **No Waiver.** No delay on the part of any Party hereto in exercising any right, power or privilege hereunder shall operate as a waiver thereof, nor shall any waiver on the part of any Party hereto of any right, power or privilege hereunder operate as a waiver of any other right, power or privilege hereunder, nor shall any single or partial exercise of any right, power or privilege hereunder, preclude any other or further exercise thereof or the exercise of any other right, power or privilege hereunder.

13. **Assignment.** Optionor shall not assign any of its rights or delegate any of its obligations hereunder. Optionee may freely assign its rights hereunder to another entity for the purpose of providing commuter rail service on the Option Property.

14. **Binding Effect.** This Agreement shall be binding upon and inure to the benefit of the Parties hereto and their respective heirs, representatives, successors and permitted assigns.

15. **Headings; Cross-References; Exhibits.** The headings and captions used in this Agreement are for convenience and ease of reference only and shall not be used to construe, interpret, expand or limit the terms of this Agreement.

16. **Counterparts.** This Agreement may be executed in any number of counterparts and by the Parties hereto in separate counterparts, each of which when so executed shall be deemed to be an original and all of which taken together shall constitute one and the same agreement.

17. **Option Runs with the Land.** This Option, and the rights and obligations herein, shall run with the Option Property and shall be binding upon, and inure to the benefit of, the parties hereto and their respective successors and assigns.

[Signatures on following page]

**SIGNATURE PAGE
TO
OPTION TO PURCHASE AGREEMENT
BY AND BETWEEN
RIVERSIDE COUNTY TRANSPORTATION COMMISSION
AND
CITY OF PERRIS**

IN WITNESS WHEREOF, the Parties have caused this Agreement to be executed by their duly authorized representatives as of the Agreement Date.

FOR "OPTIONEE"

FOR "OPTIONOR"

**RIVERSIDE COUNTY
TRANSPORTATION COMMISSION**

CITY OF PERRIS

By: _____
Anne Mayer, Executive Director

By: _____
Name: _____
Its: _____

APPROVED AS TO FORM:

ATTEST:

By: _____
Best Best & Krieger LLP
Counsel to the Riverside
County Transportation
Commission

By: _____
Its: City Clerk

APPROVED AS TO FORM:

By: _____
Aleshire & Wynder, LLP
Eric L. Dunn, City Attorney

Exhibit "A"
to
Option to Purchase Agreement

[placeholder, corrected exhibit under preparation]

NEAR PERRIS (OLD ELSINORE MUSEUM LINE)

THOSE PORTIONS OF SECTION 6, TOWNSHIP 5 SOUTH, RANGE 3 WEST, AND SECTION 31, TOWNSHIP 4 SOUTH, 3 WEST, SAN BERNARDINO BASE AND MERIDIAN, IN THE COUNTY OF RIVERSIDE, ACCORDING TO THOSE CERTAIN DEEDS RECORDED JULY 10, 1883 IN BOOK 44 PAGE 298, OF DEEDS, AND SEPTEMBER 26, 1887 IN BOOK 92 PAGE 398, OF DEEDS, BOTH RECORDS OF SAN DIEGO COUNTY, AND DEEDS RECORDED OCTOBER 2, 1958 IN BOOK 2341 PAGE 378 AND JUNE 1, 1960 IN BOOK 2706 PAGE 256 OF OFFICIAL RECORDS OF RIVERSIDE COUNTY, CALIFORNIA, MORE PARTICULARLY DESCRIBED AS FOLLOWS:

PARCEL 1:

A 200 FOOT WIDE STRIP OF LAND LOCATED IN SECTION 6, TOWNSHIP 5 SOUTH, RANGE 3 WEST, SAN BERNARDINO BASE AND MERIDIAN, THE CENTERLINE OF WHICH BEGINS ON THE SOUTH LINE OF SAID SECTION 6, DISTANT 433.00 FEET WEST OF THE SOUTHEAST QUARTER OF THE SOUTHWEST QUARTER SECTION OF SAID SECTION 6, SAID POINT HAVING A RAILWAY ENGINEER'S STATION OF 5465 PLUS 61.00; THENCE NORTHEASTERLY TO A POINT OF INTERSECTION WITH THE SOUTH LINE OF THE SOUTHEAST QUARTER OF SECTION 31, TOWNSHIP 4 SOUTH, RANGE 3 WEST, SAN BERNARDINO BASE AND MERIDIAN, SAID POINT BEING 1558 FEET WESTERLY FROM THE SOUTHEAST CORNER OF SAID SECTION 31, A DISTANCE OF 5348.60 FEET, SAID POINT HAVING A RAILWAY ENGINEER'S STATION OF 5519 PLUS 09.6.

PARCEL 2:

A 100 FOOT WIDE STRIP OF LAND LOCATED IN THE SOUTHEAST QUARTER OF SECTION 31, TOWNSHIP 4 SOUTH, RANGE 3 WEST, SAN BERNARDINO BASE AND MERIDIAN, THE CENTERLINE OF WHICH BEGINS ON THE SOUTH LINE OF SAID SOUTHEAST QUARTER, DISTANT 1558.00 FEET WEST OF THE SOUTHEAST CORNER OF SAID SOUTHEAST QUARTER, SAID POINT HAVING AN ENGINEER'S STATION OF 5519 PLUS 09.6; THENCE NORTHEASTERLY COINCIDENT WITH THE CENTERLINE OF THE ATCHISON, TOPEKA AND SANTA FE RAILWAY COMPANY'S MAIN TRACK FOR A DISTANCE OF 1464.44 FEET, TO THE POINT OF INTERSECTION WITH THE SOUTH LINE OF 10TH STREET AND THE CENTERLINE OF SAID TRACK, SAID POINT HAVING AN ENGINEER'S STATION OF 5533 PLUS 74.04, SAID POINT BEING THE POINT OF TERMINATION.

Exhibit "B"
to
Option to Purchase Agreement
Depiction of Option Property

[attached behind this page]

**RECORDING REQUESTED BY AND
WHEN RECORDED RETURN TO:**

Riverside County Transportation Commission
4080 Lemon Street, 3rd Floor
Riverside, CA 92502-2208
Attn: Executive Director

Exempt from Recording Fee
Pursuant to Government Code Section 27383

Exempt from Documentary Transfer Tax
Pursuant to R&T Code § 11922

**QUITCLAIM DEED CONTAINING COVENANTS AND RESTRICTIONS
INCLUDING A POWER OF TERMINATION**

This Quitclaim Deed is made this ___ day of _____, 2015 ("Effective Date"), by and between the RIVERSIDE COUNTY TRANSPORTATION COMMISSION, a county transportation commission ("Grantor") and the CITY OF PERRIS, a California municipal corporation ("Grantee").

RECITALS

WHEREAS, Grantor owns in fee that certain real property, including the existing railroad track, railroad crossings and other improvements and appurtenances, in the City of Perris, Riverside County, California generally located south of 7th Street to Mapes Road, located within the City of Perris, County of Riverside, State of California (the "Property"), as more fully described in the legal description attached as Exhibit "A" and depicted in the attached Exhibit "B", both incorporated herein by reference; and

WHEREAS, the Property was subject to that certain lease agreement originally entered into by the Atchison, Topeka and Santa Fe Railway Company ("Santa Fe") and the Orange Empire Railway Museum ("OERM") dated February 12, 1979, as subsequently amended (Secretary's Contract No. 157248, as amended) ("Lease"); and

WHEREAS, the Lease was assumed by Grantor upon transfer of ownership of the Property from Santa Fe to Grantor; and

WHEREAS, Grantor and Grantee have entered into that certain Comprehensive License Agreement ("License") to provide for the conveyance of the Property to Grantee and the licensing to Grantee of certain property referred to in the License as the "Perris Depot Property" and the "New Track Property," collectively referred to as the "Licensed Property." The Licensed Property is adjacent to the Property, and both the Property and the Licensed Property properties have been used by OERM for the purpose of conducting museum train movements, both with and without passengers; and

WHEREAS, Grantor acknowledges that Grantee intends to enter into a new license agreement with OERM for the Licensed Property and the Property ("Sublicense"), for the purpose of conducting museum train movements, both with and without passengers, which movements involve the operation of historic rail equipment which includes one or more diesel locomotives, steam locomotives, electric trains, and one or more passenger cars; and

WHEREAS, Grantor does not currently require the Property for its own purposes, however, Grantor may, in the future, require the Property for the purpose of providing commuter rail service, and, therefore, has entered or intends to enter that certain Option to Purchase Agreement dated of even date herewith ("Option Agreement") with Grantee whereby Grantee, in consideration of Grantor's conveyance of the Property to Grantee pursuant to this Quitclaim Deed, grants an irrevocable option to Grantor to purchase the Property, or a portion thereof, which option shall be maintained for the period set forth therein; and

WHEREAS, Grantor now intends to convey the Property to Grantee, for continuation of its use by OERM as provided in the Sublicense, or use by Grantee as provided in the License, subject to certain restrictions and conditions, including a power of termination as set forth in this Quitclaim Deed; and

WHEREAS, Grantee acknowledges that, as a material part of the consideration for this conveyance, Grantor has reserved to itself a power of termination as provided below. Grantee acknowledges that any future exercise of the power of termination will serve a public purpose; and

WHEREAS, Grantee further acknowledges that Grantor acquired the property from Santa Fe pursuant to that certain Correction Grant Deed and Grant of Easement (San Jacinto Subdivision (Riverside County)) dated March 29, 1993, recorded in the Official Records of Riverside County as Document No. 191848 ("Correction Deed"), the terms of which are incorporated herein by reference. Pursuant to the Correction Deed, BNSF, as successor in interest to Santa Fe, retains a "Reserved Rail Freight Service Easement" and a "Reserved Rail Freight Service License" (as those terms are defined in the Correction Deed) in the properties described in the Correction Deed, which include the Property.

WHEREAS, Grantee further acknowledges that the conveyance of the Property is made subject to certain restrictions regarding its use as set forth below.

QUITCLAIM

NOW THEREFORE FOR VALUABLE CONSIDERATION, receipt of which is hereby acknowledged, Grantor hereby remises, releases and quitclaims to Grantee all of Grantor's rights, title and interest in and to that certain real property legally described in Exhibit "A" attached to and by this reference incorporated into this Quitclaim Deed subject to the rights and restrictions contained below.

Section 1. Condition of Property. Grantee acknowledges and agrees that the Property is quitclaimed by Grantor to Grantee in its "AS IS," "WHERE IS" and "SUBJECT TO ALL FAULTS," as of the date of recordation of this Quitclaim Deed, with no warranties,

expressed or implied, as to the environmental or other physical condition of the Property, the presence or absence of any patent or latent environmental or other physical condition on or in the Property, or any other matters affecting the Property.

Section 2. Prohibited Uses. Grantee covenants and agrees for itself, its successors and assigns that Grantee shall not use the Property for any purpose that may interfere with Grantor's future ability to use the Property for commuter rail service, including but not limited to the following: placing of any buildings, infrastructure, and/or permanent improvements on the Property ("Interfering Structures"), except as provided in the License or Sublicense or as otherwise approved by Grantor.

Section 3. No Transfer of Any Interest in the Property. Grantee covenants and agrees for the exclusive benefit of Grantor that Grantee will not transfer any ownership or other interest in the Property without the prior written approval of Grantor. Grantor hereby approves the Sublicense subject to Grantor's rights of review under the License.

Section 4. No Encumbrances. Grantee covenants and agrees for the exclusive benefit of Grantor that Grantee will not encumber the Property with any mortgage, deed of trust or similar financial instrument.

Section 5. Conditional Grant. Grantee covenants and agrees for itself, its successors and assigns that the conveyance of the Property from Grantor to Grantee is made upon the express condition, limitation and restriction that the Property be used for the exclusive purpose of conducting museum train movements, both with and without passengers, which is hereby intended to mean the operation of historic rail equipment, except as may be approved by Grantor. Grantee agrees for itself, its successors and assigns that the express condition, limitation and restriction set forth in this Section 5 are intended to be binding upon Grantee and its permitted successors and assigns forever.

Section 6. Covenant to Reconvey Property. Grantee covenants and agrees for the exclusive benefit of Grantor that Grantee shall reconvey the Property to Grantor, in accordance with the terms of this Quitclaim Deed, upon notification from Grantor, pursuant to Section 8(a) below, that Grantee has breached any condition, restriction or limitation set forth herein.

Section 7. Complete Restoration. Grantee covenants and agrees to keep the Property free from any Interfering Structures. If Grantor later identifies any Interfering Structures on the Property, upon notice of its intent to exercise its power of termination pursuant to Section 8(a) below or upon exercise of its option under the Option Agreement, Grantor may also provide Grantee written notice of its demand that any Interfering Structures be removed within the thirty (30) day notice period. Grantee shall, at its own cost and expense, satisfactorily remove any Interfering Structures to Grantor's reasonable satisfaction, and in the event of Grantee's failure to do so, the same may be accomplished by Grantor at Grantee's expense.

Section 8. Grantor Power of Termination Regarding Property.

(a) Grantor hereby reserves a power of termination pursuant to Civil Code Sections 885.010, et seq., exercisable by Grantor, in its sole and absolute discretion, upon ninety (90)

calendar days written notice to Grantee referencing this Section 8, to terminate the fee interest of Grantee in the Property and/or any improvements to the Property and revest such fee title in Grantor and take possession of all or any portion of the Property and any improvements located thereon, without compensation to Grantee, upon Grantee's breach of the condition set forth in Section 5 above, or upon a breach by Grantee of any other restriction contained in this Quitclaim Deed.

(b) The ninety (90) calendar day written notice specified in Section 8(a) shall specify the alleged breach of Grantee triggering Grantor's exercise of the power of termination. Grantor shall proceed with its remedy set forth in Section 8(a) only if the Grantee continues in default for a period of ninety (90) calendar days following such notice or, upon commencing to cure such default, fails to diligently and continuously prosecute said cure to satisfactory conclusion.

(c) Upon Grantor's exercise of its power of termination pursuant to this Section 8, Grantee or its successors or assigns shall convey by quitclaim deed to Grantor title to the Property, as specified in Grantor's notice pursuant to Section 8(a), and all improvements thereon. Such conveyance shall be duly acknowledged by Grantee and a notary in a manner suitable for recordation. Grantor may enforce its rights pursuant to this Section 8 by means of injunctive relief or other appropriate action filed in any court of competent jurisdiction.

(d) IMMEDIATELY FOLLOWING THE NINETY (90) DAY PERIOD SPECIFIED IN SECTION 8(A), ABOVE, GRANTOR, ITS EMPLOYEES AND AGENTS SHALL HAVE THE RIGHT TO REENTER AND TAKE POSSESSION OF ALL OR ANY PORTION OF THE PROPERTY AND ANY IMPROVEMENTS THEREON, WITHOUT FURTHER NOTICE OR COMPENSATION TO GRANTEE. BY INITIALING BELOW, GRANTEE HEREBY EXPRESSLY WAIVES, TO THE MAXIMUM EXTENT ALLOWED BY LAW, ANY AND ALL RIGHTS THAT GRANTEE MAY HAVE UNDER CALIFORNIA CIVIL CODE SECTION 791 AND CALIFORNIA CODE OF CIVIL PROCEDURE SECTION 1162, AS THOSE STATUTES MAY BE AMENDED, REPLACED, RENUMBERED OR SUBSTITUTED, OR UNDER ANY OTHER STATUTES OR COMMON LAW PRINCIPLES OF SIMILAR EFFECT.

Initials of Grantee's
Authorized Representative

(e) GRANTEE ACKNOWLEDGES AND AGREES THAT GRANTOR'S EXERCISE OF ITS POWER OF TERMINATION AND RIGHT OF REENTRY PURSUANT TO THIS SECTION 8 MAY WORK A FORFEITURE OF THE ESTATE IN THE PROPERTY CONVEYED TO GRANTEE THROUGH THIS QUITCLAIM DEED. GRANTEE HEREBY EXPRESSLY WAIVES, TO THE MAXIMUM EXTENT ALLOWED BY LAW, ANY AND ALL EQUITABLE AND LEGAL DEFENSES THAT GRANTEE MAY HAVE TO SUCH FORFEITURE, INCLUDING, BUT NOT LIMITED TO, THE DEFENSES OF LACHES, WAIVER, ESTOPPEL, SUBSTANTIAL PERFORMANCE OR COMPENSABLE DAMAGES. GRANTEE FURTHER EXPRESSLY WAIVES, TO THE MAXIMUM EXTENT ALLOWED BY LAW, ANY AND ALL RIGHTS AND DEFENSES

THAT GRANTEE MAY HAVE UNDER CALIFORNIA CIVIL CODE SECTION 3275 OR ANY OTHER STATUTE OR COMMON LAW PRINCIPLE OF SIMILAR EFFECT. GRANTEE ACKNOWLEDGES THAT THE TERMS AND CONDITIONS THIS QUITCLAIM DEED REFLECT THE POSSIBILITY OF FORFEITURE BY VIRTUE OF THE EXERCISE OF GRANTOR'S POWER OF TERMINATION PROVIDED IN THIS SECTION 8 AND FURTHER ACKNOWLEDGE THAT GRANTEE HAS RECEIVED INDEPENDENT AND ADEQUATE CONSIDERATION FOR ITS WAIVER AND RELINQUISHMENT OF RIGHTS AND REMEDIES PURSUANT TO THIS SECTION 8.

Initials of Grantee's
Authorized Representative

Section 9. Grantee Indemnity. Commencing as of the Effective Date, and to the fullest extent permitted by law, Grantee shall at all times indemnify and save harmless Grantor against and pay in full all losses, damages, or expenses that Grantor may sustain, incur or become liable for, including, but not limited to, (a) loss of or damage to property, or (b) injury to or death of persons, resulting in any manner from the Property or the use, ownership, maintenance or operation thereof on or after the Effective Date by Grantee or any third party, including, without limitation, any licensee of Grantee. The indemnification and defense obligations set forth in this Section 9 shall apply except to the extent of the sole negligence or willful misconduct of Grantor.

Section 10. Covenants, Conditions and Restrictions Run with the Land. Each of the covenants and agreements contained in this Quitclaim Deed touch and concern the Property and each of them is expressly declared to be a covenant that runs with the land for the benefit of Grantor for the entire period that such covenants are in full force and effect, regardless of whether Grantor is or remains an owner of any land or interest in land to which such covenants relate. Grantor, in the event of any breach of any such covenants, has the right to exercise all of the rights and remedies, and to maintain any actions at law or suits in equity or other proper proceedings, to enforce the curing of such breach, as provided by law.

Section 11. Duration of Covenants, Conditions and Restrictions. The covenants, conditions, restrictions and agreements of this Quitclaim Deed shall have the durations set forth below:

Section 2:	in perpetuity
Section 3:	in perpetuity
Section 4:	in perpetuity
Section 5:	in perpetuity
Section 6:	in perpetuity
Section 7:	in perpetuity
Section 9:	in perpetuity

Section 12. Interpretation as Condition Subsequent. It is the intent of Grantor in executing this Quitclaim Deed that all of the covenants, conditions, restrictions and agreements set forth in this Quitclaim Deed be given full force and effect in favor of Grantor, as Grantor would not have executed this Quitclaim Deed without such covenants, conditions, restrictions

and agreements, and that each such covenant, condition, restriction and agreement should be considered, as necessary to its enforcement in favor of the Grantor, as a condition subsequent to the conveyance of this Quitclaim Deed.

Section 13. BNSF Reservation of Easement and License; Obligations of Grantee. Notwithstanding any other provision herein, this Quitclaim Deed and the rights granted hereunder are expressly subject to the Correction Deed and the rights and obligations of the parties thereunder including, but not limited to, BNSF's "Reserved Rail Freight Service Easement" and "Reserved Rail Freight Service License", as well as the rights and obligations under the Shared Use Agreement (as referenced in the Correction Deed) as such rights and obligations pertain to the Property. As successor in interest to the Property, Grantee shall be responsible for all obligations of Grantor (as defined herein) under the Correction Deed and the Shared Use Agreement, as such obligations pertain to the Property.

Section 14. Costs and Attorneys' Fees. If legal proceedings are initiated to enforce the rights, duties or obligations of any of the covenants set forth in this Quitclaim Deed, then the prevailing party in such proceeding shall be entitled to collect its reasonable attorney fees and costs from the other party in addition to any other damages or relief obtained in such proceedings.

Section 15. Severability. In the event that any provision of this Quitclaim Deed is held to be invalid, unenforceable or unlawful by a final judgment of a court of competent jurisdiction, such invalidity or unenforceability shall not affect the validity or enforceability of any other provision of this Quitclaim Deed.

Section 14. Incorporation of Recitals. The Recitals set forth above are true and correct and are incorporated into this Quitclaim Deed by reference as though fully set forth herein.

[SIGNATURES ON FOLLOWING PAGE]

**QUITCLAIM DEED
SUBJECT TO POWER OF TERMINATION**

IN WITNESS WHEREOF, the Grantor and the Grantee have caused this instrument to be executed on their behalf by their respective and duly authorized officers, on the following dates, effective as of _____, 2015.

GRANTOR:

Dated: _____

RIVERSIDE COUNTY TRANSPORTATION
COMMISSION, a county transportation commission

By: _____
Anne Mayer
Executive Director

GRANTEE:

Dated: _____

CITY OF PERRIS, a California municipal corporation

By: _____

Its: _____

ATTEST:

By: _____

Its: City Clerk

EXHIBIT A

LEGAL DESCRIPTION OF THE PROPERTY

[placeholder, corrected exhibit under preparation]

NEAR PERRIS (OLD ELSINORE MUSEUM LINE)

THOSE PORTIONS OF SECTION 6, TOWNSHIP 5 SOUTH, RANGE 3 WEST, AND SECTION 31, TOWNSHIP 4 SOUTH, 3 WEST, SAN BERNARDINO BASE AND MERIDIAN, IN THE COUNTY OF RIVERSIDE, ACCORDING TO THOSE CERTAIN DEEDS RECORDED JULY 10, 1883 IN BOOK 44 PAGE 298, OF DEEDS, AND SEPTEMBER 26, 1887 IN BOOK 92 PAGE 398, OF DEEDS, BOTH RECORDS OF SAN DIEGO COUNTY, AND DEEDS RECORDED OCTOBER 2, 1958 IN BOOK 2341 PAGE 378 AND JUNE 1, 1960 IN BOOK 2706 PAGE 256 OF OFFICIAL RECORDS OF RIVERSIDE COUNTY, CALIFORNIA, MORE PARTICULARLY DESCRIBED AS FOLLOWS:

PARCEL 1:

A 200 FOOT WIDE STRIP OF LAND LOCATED IN SECTION 6, TOWNSHIP 5 SOUTH, RANGE 3 WEST, SAN BERNARDINO BASE AND MERIDIAN, THE CENTERLINE OF WHICH BEGINS ON THE SOUTH LINE OF SAID SECTION 6, DISTANT 433.00 FEET WEST OF THE SOUTHEAST QUARTER OF THE SOUTHWEST QUARTER SECTION OF SAID SECTION 6, SAID POINT HAVING A RAILWAY ENGINEER'S STATION OF 5465 PLUS 61.00; THENCE NORTHEASTERLY TO A POINT OF INTERSECTION WITH THE SOUTH LINE OF THE SOUTHEAST QUARTER OF SECTION 31, TOWNSHIP 4 SOUTH, RANGE 3 WEST, SAN BERNARDINO BASE AND MERIDIAN, SAID POINT BEING 1558 FEET WESTERLY FROM THE SOUTHEAST CORNER OF SAID SECTION 31, A DISTANCE OF 5348.60 FEET, SAID POINT HAVING A RAILWAY ENGINEER'S STATION OF 5519 PLUS 09.6.

PARCEL 2:

A 100 FOOT WIDE STRIP OF LAND LOCATED IN THE SOUTHEAST QUARTER OF SECTION 31, TOWNSHIP 4 SOUTH, RANGE 3 WEST, SAN BERNARDINO BASE AND MERIDIAN, THE CENTERLINE OF WHICH BEGINS ON THE SOUTH LINE OF SAID SOUTHEAST QUARTER, DISTANT 1558.00 FEET WEST OF THE SOUTHEAST CORNER OF SAID SOUTHEAST QUARTER, SAID POINT HAVING AN ENGINEER'S STATION OF 5519 PLUS 09.6; THENCE NORTHEASTERLY COINCIDENT WITH THE CENTERLINE OF THE ATCHISON, TOPEKA AND SANTA FE RAILWAY COMPANY'S MAIN TRACK FOR A DISTANCE OF 1464.44 FEET, TO THE POINT OF INTERSECTION WITH THE SOUTH LINE OF 10TH STREET AND THE CENTERLINE OF SAID TRACK, SAID POINT HAVING AN ENGINEER'S STATION OF 5533 PLUS 74.04, SAID POINT BEING THE POINT OF TERMINATION.

EXHIBIT B
DEPICTION OF PROPERTY

[attached behind this page]

**CITY OF PERRIS
CERTIFICATE OF ACCEPTANCE OF
QUITCLAIM DEED**

This Certificate of Acceptance pertains to the interest in certain real property conveyed by the Quitclaim Deed dated _____ to which this Certificate of Acceptance is attached,

from: **RIVERSIDE COUNTY TRANSPORTATION COMMISSION, a county transportation commission ("Grantor"),**

to: **CITY OF PERRIS, a California municipal corporation ("Grantee"),**

Said Quitclaim Deed is hereby accepted by the undersigned officer on behalf of Grantee pursuant to authority conferred by the Grantee's governing board, and Grantee hereby consents to recordation of said Quitclaim Deed.

Dated: _____

CITY OF PERRIS, a California municipal corp.

By: _____

Its: Mayor

ATTEST:

Grantor Clerk

Notary Acknowledgment

(Attached to Quitclaim Deed Containing Covenants and Restrictions Including a Power of Termination)

A notary public or other officer completing this certificate verifies only the identity of the individual who signed the document to which this certificate is attached, and not the truthfulness, accuracy, or validity of that document.

STATE OF CALIFORNIA
COUNTY OF _____

On _____, before me, _____, Notary Public,
Date Name And Title Of Officer (e.g. "Jane Doe, Notary Public")

personally appeared _____,
Name(s) of Signer(s)

who proved to me on the basis of satisfactory evidence to be the person(s) whose name(s) is/are subscribed to the within instrument and acknowledged to me that he/she/they executed the same in his/her/their authorized capacity(ies), and that by his/her/their signature(s) on the instrument the person(s), or the entity upon behalf of which the person(s) acted, executed the instrument.

I certify under PENALTY OF PERJURY under the laws of the State of California that the foregoing paragraph is true and correct.

WITNESS my hand and official seal.

Place Notary Seal Above

Signature of Notary Public

OPTIONAL

Though the information below is not required by law, it may prove valuable to persons relying on the document and could prevent fraudulent removal and reattachment of this form to another document.

CAPACITY CLAIMED BY SIGNER

DESCRIPTION OF ATTACHED DOCUMENT

- Individual
 Corporate Officer

- _____
Title(s)
 Partner(s) Limited
 Attorney-In-Fact General
 Trustee(s)
 Guardian/Conservator
 Other: _____

Title or Type of Document

Number Of Pages

Date Of Document

Signer is representing:
Name Of Person(s) Or Entity(ies)

Signer(s) Other Than Named Above

**RIVERSIDE COUNTY TRANSPORTATION COMMISSION
LICENSE AGREEMENT
WITH THE CITY OF PERRIS FOR PARKING
ALONG D STREET BETWEEN 1ST AND 3RD
AND FOR WALKWAY ALONG D STREET BETWEEN 1ST AND 2ND**

1. Parties and Date.

THIS LICENSE AGREEMENT (hereinafter referred to as the "Agreement"), is made this ____ day of _____, 2015 by and between the RIVERSIDE COUNTY TRANSPORTATION COMMISSION, a public agency existing under the authority of the laws of the State of California (hereinafter referred to as "Licensor"), and the CITY OF PERRIS, a public agency existing under the authority of the laws of the State of California (hereinafter referred to as "Licensee"):

2. Recitals.

2.1 Licensor is the owner in fee of certain real property located along D Street between First Street and Third Street within the City of Perris, California, and improved with a parking lot ("Station Parcel") serving the Perris Valley Line Metrolink Station (the "Station").

2.2 Licensee desires to obtain a license to utilize that portion of the Station Parcel directly to the north of and adjacent to the businesses located on D Street between First and Third Street ("D Street Businesses"), and comprised of 58 total parking spaces, as depicted on Exhibit "A" (the "Licensed Spaces"), in order to provide parking for D Street Business patrons. The term "Licensed Spaces", as used herein, also includes the drive aisle depicted on Exhibit "A", and necessary for access to the parking spaces licensed hereunder.

2.3 Patrons of the commercial tenants located on the ground floor of the adjacent senior development located on D Street between First Street and San Jacinto Avenue shall also be considered D Street Business patrons, as that term is used in this Agreement.

2.4 Licensee also desires to obtain a license to utilize that portion of Licensor's property located directly between the Licensed Spaces and the D Street Businesses between First and Second Street, which is 1,625 sq. feet of unimproved land to be used by Licensee to provide an ADA compliant walkway (the "Walkway") for the D Street Businesses located between First and Second Street to move their trash bins to and from trash pick-up locations to be provided by Licensee or the D Street

Businesses on First Street and/or Second Street. The Walkway is as depicted on Exhibit "B".

2.5 Licensor desires to grant to Licensee a license for use of the Licensed Spaces and the Walkway subject to the terms and conditions in this Agreement.

3. Terms.

3.1 General Grant of License. Subject to the terms and conditions hereinafter set forth, Licensor hereby grants to Licensee a revocable, non-exclusive license for:

3.1.1 The Licensed Spaces for the purpose of allowing Licensee to provide parking for D Street Business patrons, and, if required by Licensor, to place signage related to such parking, as described in Section 3.2.2 below, and to tow impermissibly parked vehicles if signage is installed.

3.1.2 The Walkway for the purpose of allowing Licensee to provide access for the D Street Businesses to move their trash bins to and from trash pick-up locations to be provided by Licensee or the D Street Businesses on First Street and/or Second Street.

3.1.3 The Licensed Spaces and the Walkway are sometimes referred to herein, collectively, as the "Licensed Property", as depicted in Exhibits "A" and "B".

3.2 Use.

3.2.1 General Terms of Use. Licensee shall use the Licensed Property solely for the purposes set forth in Section 3.1 above, and the Licensed Property shall not be used for any other purpose whatsoever. No change shall be made by Licensee in the use of the Licensed Property without Licensor's prior written approval.

3.2.2 Special Terms of Use Related to Licensed Spaces. Use of the Licensed Spaces shall be further limited as follows:

A. The intent is that no more than thirty percent (30%) of the Licensed Spaces shall be used, at any one time, for the purpose of providing parking for D Street Business patrons, and that the remainder of the Licensed Spaces shall be available for Station patrons.

B. D Street Business patrons may use the Licensed Spaces for short term parking only. No overnight parking or parking after midnight shall be permitted.

C. The Licensed Spaces shall not be used as residential tenant or visitor parking for the adjacent senior development located on D Street between First Street and San Jacinto Avenue. Patrons of the commercial tenants located on the

ground floor of said development may utilize the Licensed Spaces subject to the limitation set forth herein, and provided that such use does not negatively impact the use of the Station Parcel by the Station Parcel Patrons.

D. This Agreement is entered into based on the understanding and agreement that use of the Licensed Spaces as contemplated hereunder shall not impact the security of the Station or its patrons, and shall not increase vandalism or trash. Licensor shall have the right to terminate this Agreement for cause, pursuant to Section 3.3.1(B) below, if Licensor determines, in its sole discretion, that Licensee's use of the Licensed Spaces is causing a negative impact on security, safety or maintenance of the Station Parcel, or if there is insufficient parking available for Station Parcel Patrons.

E. If required by Licensor, Licensee shall place signage identifying the limitations on use of the Licensed Spaces, and providing for towing of vehicles that violate the permitted usage of the Licensed Spaces. If signage is required by Licensor, Licensee shall, in accordance with applicable law, tow vehicles impermissibly parked in the Licensed Spaces. Licensee shall provide any and all proposed signage to Licensor for review and approval prior to installation.

3.2.3 No Interference. Except as provided herein, Licensee shall not use or allow the use of the Licensed Property in such a manner as to interfere with the rights of Licensor, its guest, invitees and patrons to use and enjoy the Station Parcel. Licensee shall not install, construct, or maintain and shall not permit the installation, construction or maintenance, except by Licensor, of any fence, wall, or other improvement that would block the access or parking rights granted herein. Licensee shall at all times keep a space of twenty-five (25) feet from the nearest rail of any railroad track entirely clear of structures, material and obstructions of every sort owned by Licensee, or any Invitee, employee or contractor of Licensee. Licensee shall remove any such obstructions, regardless of the source, immediately upon notice from Licensor. For the purposes of this Agreement, an "Invitee" shall mean: (i) a D Street Business owner using the Walkway for its intended purpose, or (ii) a D Street Business patron using the Licensed Spaces for its intended purpose.

3.2.4 Concurrent/Overlapping Use of Licensed Spaces. Licensor and Licensee acknowledge that Licensee's use of the Licensed Spaces will be nonexclusive and that Licensor intends to utilize the Licensed Spaces for pedestrian and vehicular access, ingress, egress and parking in connection with commuter rail and bus services to be provided by Licensor or other transportation agencies. Licensor and Licensee anticipate that the Licensed Spaces will be utilized by commuter rail and bus patrons, tenants, employees and invitees of Licensor (collectively "Station Parcel Patrons") during normal business hours, including the commuting periods before and after such hours. Licensor and Licensee acknowledge that, subject to the limitations on the Station Parcel described in Sections 3.2.1. and 3.2.2. above, the Licensed Spaces will be available to the general public and the Station Parcel Patrons on a first come, first served basis. Licensor hereby expressly excepts and reserves the right, to be

exercised by Licensor and by any others who have obtained or may obtain permission or authority from Licensor so to do, (a) to operate, maintain, renew and relocate any and all existing pipe, power, and communication lines and appurtenances and other facilities of like character upon, over or under the surface of the Licensed Property; and (b) from time to time to construct, operate, maintain, renew and relocate such additional facilities of the same character.

3.3 Termination of License.

3.3.1 Notwithstanding any other term or provision of this Agreement, Licensor shall have the right to terminate this Agreement and shall have no obligation to reimburse Licensee for any of its improvements to the Licensed Property, under any of the following circumstances:

A. In the event that Licensor determines in its sole discretion that it requires the Licensed Property for its own uses, which determination shall be made by the Executive Director or his or her designee and shall not require proof of or satisfaction of any legal standard of necessity. Should Licensor exercise this option, Licensor may terminate this Agreement by providing sixty (60) days written notice to Licensee of the intent to terminate this Agreement.

B. Licensor may terminate this Agreement at any time for cause, for a breach by Licensee of any covenant or term of this Agreement, or a default by Licensee of any term or provision of this Agreement, which acts of Licensee shall include but not be limited to: (i) the failure by Licensee to pay any amount in full when it is due under this Agreement; or (ii) the failure by Licensee to perform any obligation under this Agreement. Notification of such termination shall be in writing.

3.3.2 Licensee may terminate this Agreement at any time for its convenience by providing written notice to Licensor thirty (30) days prior to the date of termination.

3.4 Hazardous Materials Use and Related Indemnity.

3.4.1 Use and Termination. Licensee covenants that it will not handle or transport Hazardous Materials on the Licensed Property. As used in this license, "Hazardous Materials" means any chemical, substance or material which is now or becomes in the future listed, defined or regulated in any manner by any Environmental Law based upon, directly or indirectly, its properties or effects. As used in this preceding sentence, "Environmental Law" means any federal, state or local environmental, health and/or safety-related laws, regulations, standards, decisions of the courts, permits or permit conditions, currently existing or as amended or adopted in the future which are or become applicable to the Licensee or the Licensed Property. In the event the Licensed Property is now or in the future used in the handling or transporting of Hazardous Materials, Licensee agrees fully to comply with all applicable federal, state, and local laws, rules, regulations, orders, decisions and ordinances

(hereinafter referred to as "Hazardous Materials Standards") concerning Hazardous Materials. Licensee further agrees that at Licensor's request it will furnish Licensor with proof, satisfactory to Licensor, that Licensee is in such compliance. Should Licensee not comply fully with the above-stated obligations, Licensor may, in its sole discretion, terminate this Agreement as to the Licensee by serving five (5) days' notice of termination upon Licensee. Any waiver by Licensor of any breach of Licensee's obligation shall not constitute a waiver of the right to terminate this Agreement for any subsequent breach which may occur, or to enforce any other provision of this Agreement. Upon termination, Licensee shall restore the Licensed Property and any property of Licensor adjacent to the Licensed Property ("Licensor's Property") as herein provided. Licensee shall require its tenant(s), if any, to comply with the requirements of this paragraph.

3.4.2 Indemnity. Notwithstanding anything else contained in this Agreement and to the extent permitted by law, in case of a breach of the obligations contained in this Section 3.4 or the discharge of Hazardous Materials by the general public, except for the sole negligence or willful misconduct of Licensor, Licensee agrees to assume liability for and to save and hold harmless Licensor from and against any and all injuries to any person, including wrongful death, and damage to property, including without limitation, property of Licensor and Licensee, and all related expenses, including without limitation attorneys' fees, investigators' fees and litigation expenses, resulting in whole or in part from the failure of Licensee or any of its invitees to comply with any Hazardous Materials Standards issued by any governmental authority concerning Hazardous Materials. Licensee, at its cost, shall assume the defense of all claims, in accordance with Section 3.15 hereof. Licensee agrees to reimburse Licensor for all costs of any kind incurred as a result of the Licensee's failure to comply with this Section 3.4, including, but not limited to, fines, penalties, clean-up and disposal costs, and legal costs incurred as a result of the handling, transporting, or disposing of Hazardous Materials on the property of Licensor by the Licensee.

3.5 Fees and Taxes.

3.5.1 Consideration. Licensor shall bill the Licensee yearly, on the first day of January, \$1.00 for the use of the License granted hereby.

3.5.2 Taxes. Licensee shall be liable for and agrees to pay promptly and prior to delinquency, any tax or assessment, including but not limited to any possessory interest tax, levied by any governmental authority against the Licensed Property and/or any personal property, fixtures or equipment of Licensee used in connection therewith.

3.6 Maintenance and Repair.

3.6.1 Licensee Obligations for the Walkway. Licensee shall, at its sole cost and expense, maintain and repair the Walkway, and any improvements by Licensee thereto. Any repair and maintenance work shall be done to Licensor's standards. Licensee shall

provide Licensor no less than three (3) days written notice and shall acquire all necessary approvals from Licensor prior to Licensee's commencement of any such repair and maintenance work. If, at any time, Licensee shall, in the judgment of Licensor, fail to perform properly its obligations under this section, Licensor may, at its option, perform such work itself as it deems necessary for the safe operation of its property. In such event, Licensee agrees to pay, within fifteen (15) days after a bill is rendered therefor, the cost so incurred by Licensor. However, failure on the part of Licensor to perform the obligations of Licensee shall not release Licensee from liability hereunder for any loss or damage occasioned thereby.

3.6.2 Licensed Spaces - Joint Obligations. The parties shall determine cost sharing provisions for maintenance of the Licensed Spaces determined appropriate by the parties, and shall enter into an amendment to this Agreement or a separate agreement for maintenance of the Licensed Spaces. Licensee shall, at all times, maintain any signs placed on the Licensed Spaces in good condition and repair. Licensee's City Manager shall be authorized to amend this Agreement to carry out the foregoing joint maintenance obligations without formal action of the Licensee's City Council.

3.7 Standards. Licensee shall comply with all statutes, ordinances, rules, regulations, orders and decisions (hereinafter referred to as "Standards"), issued by any federal, state or local governmental body or agency established thereby including without limitation, the Interstate Railroad Commission, the California Public Utilities Commission and the Southern California Regional Rail Authority, (hereinafter collectively referred to as "Agency"), relating to Licensee's use of the Licensed Property hereunder. In its use of the Licensed Property, Licensee shall at all times be in full compliance with all Standards, present or future, set by any Agency, including, but not limited to, Standards concerning air quality, water quality, noise, and Hazardous Materials. In the event a Licensee fails to be in full compliance with Standards set by any Agency, Licensor may, but shall not be obligated to, after giving notice of the failure to Licensee, and if Licensee, within fifteen (15) days of such notice, fails to correct such non-compliance, take whatever action it determines in its sole discretion to be necessary to protect the Licensed Property and Licensor's railroad and other adjacent property. Licensee shall reimburse the Licensor for all costs (including but not limited to, consulting, engineering, clean-up and disposal, and legal costs) incurred by the Licensor as a result of the Licensee's failure to comply with such Standards, and also such costs incurred by the Licensor in abating a violation of such Standards, protecting against a threatened violation of such Standards, defending any claim of violation of such Standards in any proceeding before any Agency or court, and paying any fines or penalties imposed for such violations. Licensee shall, to the extent permitted by law, assume liability for and shall save and hold harmless the Licensor from any claim of a violation of the Standards regardless of the nature thereof or the Agency or person asserting such claim, which results from Licensee's use of Licensed Property, whether such claim arises in whole or in part from the negligence or alleged negligence of the

Licensor or otherwise. Licensee, at its cost, shall assume the defense of all such claims as provided for in Section 3.15 hereof.

3.8 Tests and Inspections. Licensor shall have the right at any time to inspect the Licensed Property so as to monitor compliance with this Agreement. If, in Licensor's sole judgment, any installation on, or use or condition of the Licensed Property may have an adverse effect on its property, adjacent property (whether or not owned by Licensor) or Licensor's operations, Licensor shall be permitted to conduct any tests or assessments, including but not limited to environmental assessments, of, on or about the Licensed Property, as it determines to be necessary or useful to evaluate the condition of the Licensed Property. Licensee shall cooperate with Licensor in any tests or inspections deemed necessary by Licensor. Licensee shall pay or reimburse Licensor, as appropriate, for all reasonable costs and expenses incurred due to the tests, inspections or any necessary corrective work and inspections thereafter within thirty days of a request for payment.

3.9 Construction and Installation.

3.9.1 Any improvements to the Walkway and the installation, repair and maintenance of signs on the Licensed Spaces (the "Project") shall be completed at Licensee's sole cost in accordance with plans approved in advance by Licensor.

3.9.2 The Project shall be accomplished in such a manner so that it will not interfere with or be a source of danger to the safe operation of the Station Parcel. The Project shall be conducted at a distance no less than fifty (50) feet from the tracks. Any aspect of the Project which will interfere with any uses on the Station Parcel, or any other property of Licensor shall be approved in advance by Licensor. Licensor may require that Licensor's representative be present during some or all of the conducting of the Project. If Licensor's representative determines that the Project is not being accomplished in accordance with this Agreement, he may, but shall not be required to, halt the work. Notwithstanding the presence of Licensor's representative, Licensee shall, at all times, retain full liability and responsibility for all aspects of the Project.

3.9.3 Licensee shall reimburse Licensor for any expense incurred by Licensor on account of the Project; including, without limitation, the cost of Licensor's representatives. Licensee shall notify Licensor's Property Agent both in writing, at the address provided in Section 3.28 below, and verbally, at (951) 787-7141, at least five (5) days prior to construction.

3.10 Underground Storage Tanks. Licensee shall not install or use any underground storage tanks on the Licensed Property unless specifically approved in advance in writing by Licensor, which approval may be withheld in Licensor's sole discretion. At Licensor's option, upon the termination of this Agreement at any time and for any reason, Licensee shall, prior to the effective date of such termination, remove and close all underground storage tanks and related equipment and clean up and

remove all Hazardous Materials in, on, under and about the Licensor's Property, in accordance with the requirements of all federal, state and local environmental laws and to the satisfaction of Licensor and any governmental authorities having jurisdiction thereof, and deliver to Licensor a copy of a certificate of closure issued for such tanks by the appropriate governmental authority.

3.11 Insurance. Licensee, at its sole cost and expense, shall obtain and maintain in full force and effect insurance as required by Licensor in the amounts and coverage specified and issued by insurance companies as described on Exhibit "C". Licensor reserves the right, to review and change the amount and type of insurance coverage it requires in connection with this agreement. Prior to the general public having access to the Licensed Property, Licensee shall furnish Licensor with the insurance endorsements and certificates in the form and amounts specified in Exhibit "C," evidencing the existence, amounts and coverage of the insurance required to be maintained hereunder.

3.12 Subordinate Rights. This Agreement is subject and subordinate to the prior and future rights and obligations of Licensor, its successors and assigns, to use its property in the exercise of its powers and in the performance of its duties, including those as a County transportation commission and a member of the Southern California Regional Rail Authority. Accordingly, there is reserved and retained unto Licensor, its successors, assigns and permittees, the right to construct, reconstruct, maintain and use existing and future rail tracks, facilities and appurtenances and existing and future transportation, communication and other facilities and appurtenances in, upon, over, under, across and along the Licensed Property, and in connection therewith, the right to grant and convey to others, rights and interests to the Licensed Property in, on and around the Licensed Property. This Agreement is subject to all licenses, leases, easements, restrictions, conditions, covenants, encumbrances, liens, claims and other matters of title (hereinafter referred to as "Title Exceptions") which may affect the Licensed Property now or hereafter, and the words "grant" or "convey" as used herein shall not be construed as a covenant against the existence of any such Title Exceptions. This Agreement is also subordinate to the Shared Use Agreement executed between the Licensor and Santa Fe dated as of October 30, 1992 and any subsequent amendments thereto.

3.13 Indemnity/Hold Harmless. Licensee shall at all times indemnify and save harmless Licensor against and pay in full all losses, damages, or expenses that Licensor may sustain, incur or become liable for, resulting in any manner from (i) the construction, installation, repair or maintenance of the Project, (ii) the use by Licensee, its employees, contractors or Invitees of the Licensed Spaces, (iii) the use and/or maintenance of the Walkway (iii) any towing of vehicles by or on behalf of Licensee. The foregoing shall include, but is not limited to, indemnification for any such losses, damages or expenses arising out of (a) loss of or damage to property, (b) injury to or death of persons, (c) mechanics' or other liens of any character, (d) taxes or assessments of any kind, or (e) interference with the use of the Licensor's tracks.

3.24 Eviction, Abandonment or Sale. In the case of the eviction of Licensee by anyone owning or obtaining title to the premises, or the sale or abandonment by Licensor of said premises, Licensor shall not be liable to Licensee for any damage of any nature whatsoever or to refund any payment made by Licensee to Licensor hereunder, except the proportionate part of any recurring rental charge which may have been paid hereunder in advance.

3.25 Condemnation. In the event all or any portion of the Licensed Property shall be taken or condemned for public use, any damages arising out of such taking or condemnation awarded to Licensee are hereby assigned by Licensee to Licensor, excepting any portion of damages attributable to improvements constructed or installed by Licensee.

3.26 Revocable License. Notwithstanding any improvements made by Licensee to the Licensed Property, or other sums expended by Licensee in furtherance of this Agreement, the license granted herein is revocable and may be terminated by Licensor. This Agreement and the license granted herein is given by Licensor and accepted by the Licensee upon the express condition that it may be terminated at any time by Licensor upon one-hundred eighty (180) days' notice in writing to be served upon Licensee. Such notice shall state therein the effective date of termination. The rights under this section are in addition to any other termination rights contained in this Agreement.

3.27 Restoration of Licensor's Property, Claims for Costs. Upon the termination, revocation or cessation of this Agreement in any manner provided in this Agreement, Licensee, upon demand of Licensor and at Licensee's own cost and expense, shall abandon the Project, as defined in Section 3.9.1, and remove it and restore the Licensed Property to the same condition in which it was prior to the conducting of the Project, reasonable wear and tear excepted. In no event shall Licensee have any claim against Licensor for any of the costs of conducting, maintaining or removing the Project. In case Licensee shall fail to restore the Licensed Property as aforesaid within ten (10) days after the effective date of termination, Licensor may proceed with such work at the expense of Licensee or may assume title and ownership of the Project and any other property of Licensee located on the Licensed Property. No termination hereof shall release Licensee from any liability or obligation hereunder, whether of indemnity or otherwise, resulting from any acts, omissions or events happening prior to the date the Project is removed and the Licensed Property restored as provided herein.

3.28 Notice. Notices hereunder to be given shall be deemed to be properly served on the date it is deposited in the United States Mail, postage prepaid, addressed to the following:

The Licenser

Executive Director
Riverside County Transportation Commission
Riverside County Regional Complex
4080 Lemon Street, Third Floor
Riverside, CA 92502-2208

The Licensee

City Manager
City of Perris
101 North D Street
Perris, CA 92570-1998

Licenser or Licensee may change its address for the receipt of notice by giving written notice thereof to the other party of such change.

3.29 Nondiscrimination. Licensee certifies and agrees that all persons employed thereby and/or the affiliates, subsidiaries, or holding companies thereof and any contractors retained thereby with respect to the Licensed Property are and shall be treated equally without regard to or because of race, religion, ancestry, national origin, or sex, and in compliance with all federal and state laws prohibiting discrimination in employment, including but not limited to the Civil Rights Act of 1964; the Unruh Civil Rights Act; the Cartwright Act; and the California Fair Employment Practices Act.

3.30 Further Acts. Licensee agrees to perform any further acts and to execute and deliver in recordable form any documents which may be reasonably necessary to carry out the provisions of this Agreement and the license granted by this Agreement.

3.31 Liens. Licensee shall not permit to be placed against the Licensed Property, or any part thereof, any design professionals', mechanics', materialmen's contractors' or subcontractors' liens with regard to the actions upon the Licensed Property of the Licensee. Licensee agrees to hold Licenser harmless for any loss or expense, including reasonable attorneys' fees and costs, arising from any such liens which might be filed against the Licensed Property.

3.32 Interest on Past-due Obligations. Except as expressly herein provided, any amount due to Licenser which is not paid when due shall bear interest, from the date due, at the rate of ten percent (10%) per annum. Such interest will be due Licenser as it accrues. Payment of such interest shall not excuse or cure any default by Licensee under this Agreement, provided, however, that interest shall not be payable on late charges incurred by Licensee.

3.33 Non-Exclusive License. The license granted by this Agreement is not exclusive and Licenser specifically reserves the right to grant other licenses within the vicinity of the Licensed Property.

3.34 Severability. If any term, covenant, condition or provision of this Agreement, or the application thereof to any person or circumstance, shall to any extent be held by a court of competent jurisdiction to be invalid, void or unenforceable, the

remainder of the terms, covenants, conditions, or provisions of this Agreement, or the application thereof to any person or circumstance, shall remain in full force and effect and shall in no way be affected, impaired or invalidated thereby.

3.35 Captions. The Captions included in this Agreement are for convenience only and in no way define, limit, or otherwise describe the scope or intent of this Agreement or any provision hereof, or in any way affect the interpretation of this Agreement.

3.36 Time of Essence. Time is of the essence in this Agreement.

3.37 No Recording. Licensee shall not record or permit to be recorded in the official records of the county where the Licensed Property is located any memorandum of this Agreement or any other document giving notice of the existence of this Agreement or the license granted hereby.

3.38 Entire Agreement. This Agreement and the Exhibits hereto constitute the entire agreement between the Licensor and Licensee with respect to the subject matter hereof and supersede all prior verbal or written agreements and understandings between the parties with respect to the items set forth herein.

3.39 Governing Law. This Agreement shall be governed by the laws of the State of California.

3.40 Counterparts. This Agreement may be executed in counterparts. It shall not become effective upon any party until it has been executed by all parties.

[Signatures on following page]

**RIVERSIDE COUNTY TRANSPORTATION COMMISSION
LICENSE AGREEMENT
WITH THE CITY OF PERRIS FOR PARKING
ALONG D STREET BETWEEN 1ST AND 3RD
AND FOR WALKWAY ALONG D STREET BETWEEN 1ST AND 2ND**

IN WITNESS WHEREOF, the parties have executed this Agreement in duplicate the day and year first above written.

**RIVERSIDE COUNTY
TRANSPORTATION COMMISSION**

THE CITY OF PERRIS

By: _____
Anne Mayer, Executive Director

By: _____

Its: _____

ATTEST:

City Clerk

APPROVED AS TO FORM:

APPROVED AS TO FORM:

By: _____
Best, Best & Krieger
Counsel to the Riverside
County Transportation
Commission

By: _____
City Attorney

EXHIBIT "B"

MAP DEPICTING EXACT LOCATION OF WALKWAY

[attached behind this page]

EXHIBIT "C"

INSURANCE REQUIREMENTS

Licensee shall obtain insurance in the form and amounts set forth herein prior to the general public having access to the Licensed Property. In addition, Licensee shall obtain, and shall require any consultant or contractor entering the Licensed Property on its behalf to obtain insurance of the types and in the amounts described below and satisfactory to the Commission.

A. Commercial General Liability Insurance. Licensee shall maintain occurrence version commercial general liability insurance or equivalent form with a combined single limit of not less than **\$5,000,000** per occurrence. If such insurance contains a general aggregate limit, it shall apply separately to this Agreement or be no less than two times the occurrence limit. Such insurance shall:

1. Include the Licensor, its officials, officers, employees, agents, and consultants as insureds with respect to the use of the Licensed Property and shall contain no special limitations on the scope of coverage or the protection afforded to these insureds;

2. Be primary with respect to any insurance or self insurance programs covering the Licensor, its officials, officers, employees, agents and consultants; and

3. Contain standard separation of insured provisions.

B. Automobile Liability Insurance. Licensee shall maintain automobile liability insurance with a combined single limit of no less than one million dollars (\$1,000,000).

C. Pollution Liability Insurance. N/A.

D. Workers' Compensation Insurance. Licensee shall maintain workers' compensation insurance with statutory limits and employers' liability insurance with limits of not less than **\$1,000,000** each accident.

E. Certificates of Insurance. Licensee shall, prior to commencement of Services, furnish the Licensor with properly executed certificates of insurance and, if requested by the Licensor, certified copies of endorsements and policies, which clearly evidence all insurance required under this Agreement and provide that such insurance shall be not canceled, allowed to expire or be materially reduced in coverage, except on 30 days' prior written notice to the Licensor. The Licensor shall have the sole discretion to determine whether the certificates and endorsements presented comply with the provisions of this Agreement.

EXHIBIT "C"

**RIVERSIDE COUNTY TRANSPORTATION COMMISSION
LICENSE AGREEMENT
WITH THE CITY OF PERRIS FOR PARKING NEAR THE
PERRIS MULTIMODAL TRANSPORTATION FACILITY
(ALONG D STREET BETWEEN 3RD AND 4TH STREET)**

1. Parties and Date.

THIS LICENSE AGREEMENT (hereinafter referred to as the "Agreement"), is made this ___ day of _____, 2015 by and between the **RIVERSIDE COUNTY TRANSPORTATION COMMISSION**, a public agency existing under the authority of the laws of the State of California (hereinafter referred to as "Licensor"), the **CITY OF PERRIS**, a public agency existing under the authority of the laws of the State of California (hereinafter referred to as "Licensee"):

2. Recitals.

2.1 Licensor is the owner in fee of certain property located within the City of Perris, California, as described in Exhibit "A" attached hereto (the "Station Parcel").

2.2 The Licensee was a beneficiary of rights under that certain Lease Contract dated December 1, 1967 that was superseded by Agreement No. 05-51-944.

2.3 Licensor and Licensee wish to establish for the benefit of the general public conditions for the purposes of pedestrian and vehicular access, parking, and ingress and egress over those portions of the Station Parcel as shown on Exhibit "A" attached hereto ("Licensed Property") which have been improved with surface parking and appurtenant driveways.

2.4 Licensor and Licensee previously entered into Agreement No. 05-51-944 on May 18, 2005 for the above stated purpose over other portions of the Station Parcel, identified in said agreement and generally located on D Street between Fourth Street and Fifth Street. The present Agreement, herein, grants to Licensee a license over those portions of the Station Parcel generally located on D Street between Third Street and Fourth Street as shown in Exhibit "A", which portions, in conjunction with those portions identified in Agreement No. 05-51-944 make up the whole area of parking at Station Parcel.

3. Terms.

3.1 General Grant of License. Subject to the terms and conditions hereinafter set forth, Licensor hereby grants to Licensee a revocable, non-exclusive license over the Licensed Property to provide parking to the general public on the Licensed Property.

3.2 Use.

3.2.1 General Terms of Use. Licensee shall use the Licensed Property solely for parking for the general public and Licensee, and, if required by Licensor, for the placement of signage related to such parking, as described below, and to tow impermissibly parked vehicles if signage is installed, and the Licensed Property shall not be used for any other purpose whatsoever. No change shall be made by Licensee in the use of the Licensed Property without Licensor's prior written approval.

A. If required by Licensor, Licensee shall place signage identifying the limitations on use of the Licensed Property, and providing for towing of vehicles that violate the permitted usage of the Licensed Property. If signage is required by Licensor, Licensee shall, in accordance with applicable law, tow vehicles impermissibly parked on the Licensed Property. Licensee shall provide any and all proposed signage to Licensor for review and approval prior to installation. Installation of signage shall be subject any requirements of Licensor provided in writing to Licensee.

3.2.2. No Interference. Except as provided herein, Licensee shall not use or allow the use of the Licensed Property in such a manner as to interfere with the rights of the Licensor, its guest, invitees and patrons to use and enjoy the Station Parcel. Licensee shall not install, construct, or maintain and shall not permit the installation, construction or maintenance of any fence, wall, or other improvement that would block the access or parking rights granted herein. Licensee shall at all times keep a space of twenty-five (25) feet from the nearest rail of any railroad track entirely clear of structures, material and obstructions of every sort owned by Licensee, or any Invitee, employee or contractor of Licensee. Licensee shall remove any such obstructions, regardless of the source, upon notice from Licensor. For the purposes of this Agreement, an "Invitee" shall mean a member of the general public using the Licensed Property for its intended purpose, i.e., pedestrian or vehicular access to the adjacent businesses and multimodal transportation facility.

3.2.3. Concurrent/Overlapping Use. Licensor and Licensee acknowledge that the Licensee's use of the Licensed Property will be nonexclusive and that the Licensor intends to utilize the Licensed Property for pedestrian and vehicular access, ingress, egress and parking in connection with commuter rail and bus services to be provided by the Licensor or other transportation agencies. The Licensor and the Licensee anticipate that the Licensed Property will be utilized by commuter rail and bus patrons, tenants, employees and invitees of the Licensor (collectively "Station Parcel Patrons" or "Patrons") during normal business hours, including the commuting periods before and

after such hours. Licensor and Licensee acknowledge that, subject to the limitations on the Station Parcel described in Sections 3.2.1. and 3.2.2. above, the Licensed Property will be available to the general public and the Station Parcel Patrons on a first come, first served basis. Licensor hereby expressly excepts and reserves the right, to be exercised by Licensor and by any others who have obtained or may obtain permission or authority from Licensor so to do, (a) to operate, maintain, renew and relocate any and all existing pipe, power, and communication lines and appurtenances and other facilities of like character upon, over or under the surface of the Licensed Property; and (b) from time to time to construct, operate, maintain, renew and relocate such additional facilities of the same character.

3.3 Liens. No Licensee shall permit to be placed against the Licensed Property, or any part thereof, any design professionals', mechanics', materialmen's contractors' or subcontractors' liens with regard to the actions upon the Licensed Property of the Licensee. Licensee agrees to hold Licensor harmless for any loss or expense, including reasonable attorneys' fees and costs, arising from any such liens which might be filed against the Licensed Property.

3.4 Hazardous Materials Use and Related Indemnity.

3.4.1 Use and Termination. Licensee covenants that it will not handle or transport Hazardous Materials on the Licensed Property. As used in this license, "Hazardous Materials" means any chemical, substance or material which is now or becomes in the future listed, defined or regulated in any manner by any Environmental Law based upon, directly or indirectly, its properties or effects. As used in this preceding sentence, "Environmental Law" means any federal, state or local environmental, health and/or safety-related laws, regulations, standards, decisions of the courts, permits or permit conditions, currently existing or as amended or adopted in the future which are or become applicable to the Licensee or the Licensed Property. In the event the Licensed Property is now or in the future used in the handling or transporting of Hazardous Materials, Licensee agree fully to comply with all applicable federal, state, and local laws, rules, regulations, orders, decisions and ordinances (hereinafter referred to as "Hazardous Materials Standards") concerning Hazardous Materials. Licensee further agrees that at Licensor's request it will furnish Licensor with proof, satisfactory to Licensor, that Licensee is in such compliance. Should Licensee not comply fully with the above-stated obligations, Licensor may, in its sole discretion, terminate this Agreement as to the Licensee by serving five (5) days' notice of termination upon Licensee. Any waiver by Licensor of any breach of Licensee's obligation shall not constitute a waiver of the right to terminate this Agreement for any subsequent breach which may occur, or to enforce any other provision of this Agreement. Upon termination, Licensee shall restore the Licensed Property and any property of Licensor adjacent to the Licensed Property ("Licensor's Property") as herein provided. Licensee shall require its tenant(s), if any, to comply with the requirements of this paragraph.

3.4.2 Indemnity. Notwithstanding anything else contained in this Agreement and to the extent permitted by law, in case of a breach of the obligations contained in this Section 3.4 or the discharge of Hazardous Materials by the general public, except for the sole negligence or willful misconduct of Licensor, Licensee agrees to assume liability for and to save and hold harmless Licensor from and against any and all injuries to any person, including wrongful death, and damage to property, including without limitation, property of Licensor and Licensee, and all related expenses, including without limitation attorneys' fees, investigators' fees and litigation expenses, resulting in whole or in part from the failure of Licensee or any of its invitees to comply with any Hazardous Materials Standards issued by any governmental authority concerning Hazardous Materials. Licensee, at its cost, shall assume the defense of all claims, in accordance with Section 3.15 hereof. Licensee agrees to reimburse Licensor for all costs of any kind incurred as a result of the Licensee's failure to comply with this Section 3.4, including, but not limited to, fines, penalties, clean-up and disposal costs, and legal costs incurred as a result of the handling, transporting, or disposing of Hazardous Materials on the property of Licensor by the Licensee.

3.5 Fees and Taxes.

3.5.1 Consideration. Licensor shall bill the Licensee yearly, on the first day of January, \$1.00 for the use of the License granted hereby.

3.5.2 Taxes. Licensee shall be liable for and agrees to pay promptly and prior to delinquency, any tax or assessment, including but not limited to any possessory interest tax, levied by any governmental authority against the Licensed Property and/or any personal property, fixtures or equipment of Licensee used in connection therewith.

3.6 Maintenance and Repair.

3.6.1 Licensee Obligations. At the time this Agreement is entered into, the parties agree that Licensor is not utilizing the Licensed Property for its own purposes, and Licensee is the sole entity utilizing the Licensed Property. Therefore, as the sole entity utilizing the Licensed Property, Licensee shall, at its sole cost and expense, maintain and repair the Licensed Property, including not only the improved parking area, but also the associated curbs, gutters, sidewalks, walkways, lighting, landscaping, fencing, and any other improvements made by Licensee to the Licensed Property. Any repair and maintenance work shall be done to Licensor's standards. Licensee shall provide Licensor no less than thirty (30) days written notice and shall acquire all necessary approvals from Licensor prior to Licensee's commencement of any such repair and maintenance work. If, at any time, Licensee shall, in the judgment of Licensor, fail to perform properly its obligations under this section, Licensor may, at its option, perform such work itself as it deems necessary for the safe operation of its railroad and other uses on the Licensed Property. In such event, Licensee agrees to pay, within fifteen (15) days after a bill is rendered therefor, the cost so incurred by Licensor. However, failure on the part of Licensor to perform the obligations of

Licensee shall not release Licensee from liability hereunder for any loss or damage occasioned thereby.

3.6.2 Joint Obligations. At such time as Licensor commences to utilize the Licensed Property for its own purposes (including providing a license to parties other than City), the parties shall determine any cost sharing provisions for maintenance of the Licensed Property determined appropriate by the parties, and shall amend this Agreement to address any joint maintenance obligations of the parties. Licensee's City Manager shall be authorized to amend this Agreement to carry out the foregoing joint maintenance obligations without formal action of the Licensee's City Council.

3.7 Standards. Licensee shall comply with all statutes, ordinances, rules, regulations, orders and decisions (hereinafter referred to as "Standards"), issued by any federal, state or local governmental body or agency established thereby including without limitation, the Interstate Railroad Commission, the California Public Utilities Commission and the Southern California Regional Rail Authority, (hereinafter collectively referred to as "Agency"), relating to Licensee's use of the Licensed Property hereunder. In its use of the Licensed Property, Licensee shall at all times be in full compliance with all Standards, present or future, set by any Agency, including, but not limited to, Standards concerning air quality, water quality, noise, and Hazardous Materials. In the event a Licensee fails to be in full compliance with Standards set by any Agency, Licensor may, but shall not be obligated to, after giving notice of the failure to Licensee, and if Licensee, within fifteen (15) days of such notice, fails to correct such non-compliance, take whatever action it determines in its sole discretion to be necessary to protect the Licensed Property and Licensor's railroad and other adjacent property. Licensee shall reimburse the Licensor for all costs (including but not limited to, consulting, engineering, clean-up and disposal, and legal costs) incurred by the Licensor as a result of the Licensee's failure to comply with such Standards, and also such costs incurred by the Licensor in abating a violation of such Standards, protecting against a threatened violation of such Standards, defending any claim of violation of such Standards in any proceeding before any Agency or court, and paying any fines or penalties imposed for such violations. Licensee shall, to the extent permitted by law, assume liability for and shall save and hold harmless the Licensor from any claim of a violation of the Standards regardless of the nature thereof or the Agency or person asserting such claim, which results from Licensee's use of Licensed Property, whether such claim arises in whole or in part from the negligence or alleged negligence of the Licensor or otherwise. Licensee, at its cost, shall assume the defense of all such claims as provided for in Section 3.15 hereof.

3.8 Tests and Inspections. Licensor shall have the right at any time to inspect the Licensed Property so as to monitor compliance with this Agreement. If, in Licensor's sole judgment, any installation on, or use or condition of the Licensed Property may have an adverse effect on its property, adjacent property (whether or not owned by Licensor) or Licensor's operations, Licensor shall be permitted to conduct any tests or assessments, including but not limited to environmental assessments, of, on or about

the Licensed Property, as it determines to be necessary or useful to evaluate the condition of the Licensed Property. Licensee shall cooperate with Licensor in any tests or inspections deemed necessary by Licensor. Licensee shall pay or reimburse Licensor, as appropriate, for all reasonable costs and expenses incurred due to the tests, inspections or any necessary corrective work and inspections thereafter within thirty days of a request for payment.

3.9 Construction and Installation. [Reserved]

3.10 Underground Storage Tanks. Licensee shall not install or use any underground storage tanks on the Licensed Property unless specifically approved in advance in writing by Licensor, which approval may be withheld in Licensor's sole discretion. At Licensor's option, upon the termination of this Agreement at any time and for any reason, Licensee shall, prior to the effective date of such termination, remove and close all underground storage tanks and related equipment and clean up and remove all Hazardous Materials in, on, under and about the Licensor's Property, in accordance with the requirements of all federal, state and local environmental laws and to the satisfaction of Licensor and any governmental authorities having jurisdiction thereof, and deliver to Licensor a copy of a certificate of closure issued for such tanks by the appropriate governmental authority.

3.11 Insurance. Licensee, at its sole cost and expense, shall obtain and maintain in full force and effect insurance as required by Licensor in the amounts and coverage specified and issued by insurance companies as described on Exhibit "B". Licensor reserves the right, to review and change the amount and type of insurance coverage it requires in connection with this agreement. Prior to the general public having access to the Licensed Property, Licensee shall furnish Licensor with the insurance endorsements and certificates in the form and amounts specified in Exhibit "B," evidencing the existence, amounts and coverage of the insurance required to be maintained hereunder.

3.12 Subordinate Rights. This Agreement is subject and subordinate to the prior and future rights and obligations of Licensor, its successors and assigns, to use its property in the exercise of its powers and in the performance of its duties, including those as a County transportation commission and a member of the Southern California Regional Rail Authority. Accordingly, there is reserved and retained unto Licensor, its successors, assigns and permittees, the right to construct, reconstruct, maintain and use existing and future rail tracks, facilities and appurtenances and existing and future transportation, communication and other facilities and appurtenances in, upon, over, under, across and along the Licensed Property, and in connection therewith, the right to grant and convey to others, rights and interests to the Licensed Property in, on and around the Licensed Property. This Agreement is subject to all licenses, leases, easements, restrictions, conditions, covenants, encumbrances, liens, claims and other matters of title (hereinafter referred to as "Title Exceptions") which may affect the Licensed Property now or hereafter, and the words "grant" or "convey" as used herein

shall not be construed as a covenant against the existence of any such Title Exceptions. This Agreement is also subordinate to the Shared Use Agreement executed between the Licensor and Santa Fe dated as of October 30, 1992 and any subsequent amendments thereto.

3.13 Indemnity/Hold Harmless. Licensee shall at all times indemnify and save harmless Licensor against and pay in full all losses, damages, or expenses that Licensor may sustain, incur or become liable for, resulting in any manner from the use and maintenance by the Licensee, its employees, contractors or Invitees of the Licensed Property, including, but not limited to, any such losses, damages or expenses arising out of (a) loss of or damage to property, (b) injury to or death of persons, (c) mechanics' or other liens of any character, (d) taxes or assessments of any kind, or (e) interference with the use of the Licensor's tracks, and from any towing of vehicles by or on behalf of Licensee.

3.14 Assumption of Risk and Waiver. To the maximum extent allowed by law, Licensee assumes any and all risk of loss, damage or injury of any kind to any person or property, including without limitation, the Licensed Property, Licensor's property and any other property of, or under the control or custody of the Licensee. Licensee's assumption of risk shall include, without limitation, loss or damage caused by defects in any structure or improvement on the Licensed Property, accident or fire or other casualty on the Licensed Property, or electrical discharge, and noise or vibration resulting from Licensor's transit operations on or near the Licensed Property. The term "Licensor" as used in this section shall include: (i) any transit or rail-related company operating upon or over Licensor's tracks or other property, and (ii) any other persons or companies employed, retained or engaged by Licensor. Licensee, on behalf of itself and its Personnel, as a material part of the consideration for this Agreement, hereby waives all claims and demands against Licensor for any such loss, damage or injury of Licensee and/or its Personnel. In that connection, Licensee waives, for itself and its Personnel, the benefit of California Civil Code Section 1542, which provides as follows:

A general release does not extend to claims which the creditor does not know or suspect to exist in his favor at the time of executing the release, which if known by him must have materially affected his settlement with the debtor.

The provisions of this section and of Section 3.13 and 3.15 shall survive the termination of this Agreement. As used in this section, "Personnel" means the Licensee, or its officers, directors, affiliates, or anyone directly or indirectly employed by Licensee or for whose acts Licensee is liable.

3.15 Defense. Upon written notice from Licensor, Licensee agrees to assume the defense of any lawsuit, administrative action or other proceeding brought against Licensor by any public body, individual, partnership, corporation, or other legal entity, relating to any matter covered by this Agreement for which Licensee has an obligation

a longer notice period is specifically provided for elsewhere in this Agreement (provided that the notice period set forth in Section 3.26 shall not apply to this section).

3.23 Abandonment. Should Licensee at anytime affirmatively abandon the Licensed Property, or any part thereof, or fail at any time for a continuous period of six (6) months to use the same for the purposes contemplated by this Agreement, then the Licensor may terminate this Agreement to the extent of the portion so abandoned or discontinued, upon thirty (30) days' written notice to Licensee. Lack of use of the Licensed Property or any part thereof shall not constitute affirmative abandonment. In addition to any other rights or remedies, Licensor shall immediately be entitled to exclusive possession and ownership of the portion so abandoned or discontinued, without the encumbrance of this Agreement.

3.24 Eviction, Abandonment or Sale. In the case of the eviction of Licensee by anyone owning or obtaining title to the premises, or the sale or abandonment by Licensor of said premises, Licensor shall not be liable to Licensee for any damage of any nature whatsoever or to refund any payment made by Licensee to Licensor hereunder, except the proportionate part of any recurring rental charge which may have been paid hereunder in advance.

3.25 Condemnation. In the event all or any portion of the Licensed Property shall be taken or condemned for public use, any damages arising out of such taking or condemnation awarded to Licensee are hereby assigned by Licensee to Licensor, excepting any portion of damages attributable to improvements constructed or installed by Licensee.

3.26 Revocable Licenses and Termination. Licensee agrees that notwithstanding any improvements made by Licensee to the Licensed Property, or other sums expended by Licensee in furtherance of this Agreement, the license granted herein is revocable and may be terminated by Licensor. This Agreement and the license granted herein is given by Licensor and accepted by the Licensee upon the express condition that it may be terminated at any time by either party upon sixty (60) days' notice in writing to be served upon the other party. Such notice shall state therein the date that such termination shall take place.

3.27 Notice. Notices hereunder to be given shall be deemed to be properly served on the date it is deposited in the United States Mail, postage prepaid, addressed to the following:

The Licensor
Executive Director
Riverside County Transportation Commission
Riverside County Regional Complex
4080 Lemon Street, Third Floor
Riverside, CA 92502-2208

The Licensee
City Manager
City of Perris
101 North D Street
Perris, CA 92570-1998

Licensor or Licensee may change its address for the receipt of notice by giving written notice thereof to the other Party of such change.

3.28 Nondiscrimination. Licensee certifies and agrees that all persons employed thereby and/or the affiliates, subsidiaries, or holding companies thereof and any contractors retained thereby with respect to the Licensed Property are and shall be treated equally without regard to or because of race, religion, ancestry, national origin, or sex, and in compliance with all federal and state laws prohibiting discrimination in employment, including but not limited to the Civil Rights Act of 1964; the Unruh Civil Rights Act; the Cartwright Act; and the California Fair Employment Practices Act.

3.29 Further Acts. Licensee agrees to perform any further acts and to execute and deliver in recordable form any documents which may be reasonably necessary to carry out the provisions of this Agreement and the license granted by this Agreement.

3.30 Non-Exclusive License. The license granted by this Agreement is not exclusive and Licensor specifically reserves the right to grant other licenses within the vicinity of the Licensed Property.

3.31 Severability. If any term, covenant, condition or provision of this Agreement, or the application thereof to any person or circumstance, shall to any extent be held by a court of competent jurisdiction to be invalid, void or unenforceable, the remainder of the terms, covenants, conditions, or provisions of this Agreement, or the application thereof to any person or circumstance, shall remain in full force and effect and shall in no way be affected, impaired or invalidated thereby.

3.32 Captions. The Captions included in this Agreement are for convenience only and in no way define, limit, or otherwise describe the scope or intent of this Agreement or any provision hereof, or in any way affect the interpretation of this Agreement.

3.33 Time of Essence. Time is of the essence in this Agreement.

3.34 No Recording. Licensee shall not record or permit to be recorded in the official records of the county where the Licensed Property is located any memorandum of this Agreement or any other document giving notice of the existence of this Agreement or the license granted hereby.

3.35 Entire Agreement. This Agreement and the Exhibits hereto constitute the entire agreement between the Licensor and Licensee with respect to the subject matter hereof and supersede all prior verbal or written agreements and understandings between the parties with respect to the items set forth herein.

3.36 Governing Law. This Agreement shall be governed by the laws of the State of California.

3.37 Counterparts. This Agreement may be executed in counterparts. It shall not become effective upon any Party until it has been executed by all parties.

[SIGNATURES ON FOLLOWING PAGE]

EXHIBIT "B"

INSURANCE REQUIREMENTS

Licensee shall obtain insurance in the form and amounts set forth herein prior to the general public having access to the Licensed Property. In addition, Licensee shall obtain, and shall require any consultant or contractor entering the Licensed Property on its behalf to obtain insurance of the types and in the amounts described below and satisfactory to the Commission.

A. Commercial General Liability Insurance. Licensee shall maintain occurrence version commercial general liability insurance or equivalent form with a combined single limit of not less than **\$5,000,000** per occurrence. If such insurance contains a general aggregate limit, it shall apply separately to this Agreement or be no less than two times the occurrence limit. Such insurance shall:

1. Include the Licensor, its officials, officers, employees, agents, and consultants as insureds with respect to the use of the Licensed Property and shall contain no special limitations on the scope of coverage or the protection afforded to these insureds;

2. Be primary with respect to any insurance or self insurance programs covering the Licensor, its officials, officers, employees, agents and consultants; and

3. Contain standard separation of insured provisions.

B. Railroad Protective Liability. N/A

C. Pollution Liability Insurance. N/A.

D. Workers' Compensation Insurance. Licensee shall maintain workers' compensation insurance with statutory limits and employers' liability insurance with limits of not less than **\$1,000,000** each accident.

E. Certificates of Insurance. Licensee shall, prior to commencement of Services, furnish the Licensor with properly executed certificates of insurance and, if requested by the Licensor, certified copies of endorsements and policies, which clearly evidence all insurance required under this Agreement and provide that such insurance shall be not canceled, allowed to expire or be materially reduced in coverage, except on 30 days' prior written notice to the Licensor. The Licensor shall have the sole discretion to determine whether the certificates and endorsements presented comply with the provisions of this Agreement.

EXHIBIT "B"

**LICENSE AGREEMENT
BETWEEN
RIVERSIDE COUNTY TRANSPORTATION COMMISSION
AND
CITY OF PERRIS
FOR MONUMENT SIGNS AND OTHER IMPROVEMENTS**

THIS LICENSE AGREEMENT (hereinafter referred to as the “**Agreement**”), is made this ___ day of _____, 2015 by and between the **RIVERSIDE COUNTY TRANSPORTATION COMMISSION**, a public agency existing under the authority of the laws of the State of California (hereinafter referred to as “**RCTC**”) and the **CITY OF PERRIS**, a municipal corporation (hereinafter referred to as “**City**” or “**Licensee**”). RCTC and City/Licensee are sometimes referred to herein, individually as “**Party**” and collectively, as the “**Parties**”.

RECITALS

- A. RCTC is the owner in fee of certain real property located in the City of Perris, County of Riverside, as more specifically described herein.
- B. RCTC intends to install, as part of its Perris Valley Line (“**PVL**”) Project, and at no cost to City, certain monument signs and other improvements on the property of RCTC, as agreed upon by the Parties and as further detailed herein (the “**Facility**”).
- C. The Facility includes certain non-standard and improved features requested by City as part of the City’s design review process for approval of the Facility.
- D. RCTC has agreed to include the non-standard and improved features requested by City, at no cost to City, on the agreement of the Parties that City shall be responsible for the regular and normal maintenance and repair of the Facility, as further described herein.
- E. The Parties agree that, subject to RCTC Board budget authorization, RCTC is responsible for major reconstruction of the Facility, unless such reconstruction is required as a result of City’s failure to comply with its maintenance obligations hereunder.
- F. This Agreement also includes a license for the City to install and maintain the Future Improvements, as defined in **Exhibit “C”**, subject to the terms hereof.
- G. The purpose of this Agreement is to allow City, as Licensee, to enter a certain portion of property owned by RCTC for the purpose of maintaining and repairing the Facility, as further specified in Item 2 of the Basic License Provisions.

A. Use and Termination. Licensee covenants that it will not handle or transport Hazardous Materials on the Licensed Property, or any part thereof, except as provided below in this Section. "Hazardous Materials" shall include, but shall not be limited to, substances defined as "hazardous substances, hazardous materials or toxic substances" in the Comprehensive Environmental Response, Compensation and Liability Act of 1980, as amended, 42 USC Section 9601, et seq.; the Hazardous Materials Transportation Act, 49 USC Section 1801, et seq.; the Resource Conservation and Recovery Act, 42 USC Section 6901, et seq.; those substances defined as "hazardous wastes" in Section 25117 of the California Health & Safety Code or as "hazardous substances" in Section 25316 of the California Health & Safety Code; and those chemicals known to cause cancer or reproductive toxicity, as published pursuant to the Safe Drinking Water and Toxic Enforcement Act of 1986, Section 25249.5, et seq., of the California Health & Safety Code; and in the regulations adopted and publications promulgated pursuant to each of the aforesaid laws), as may be amended. If at any time, Hazardous Materials are utilized or transported by Licensee on the Licensed Property, or any part thereof, Licensee agrees fully to comply with all applicable federal, state, and local laws, rules, regulations, orders, decisions and ordinances (hereinafter referred to as "Hazardous Materials Standards") concerning Hazardous Materials. Licensee further agrees that at RCTC's request it will furnish RCTC with proof, reasonably satisfactory to RCTC, that Licensee is in such compliance. Licensee's failure to comply with the requirements of this Section shall constitute a breach of this Agreement.

B. Indemnity. Notwithstanding anything else contained in this Agreement and to the extent permitted by law, in case of a breach of the obligations contained in this Section, Licensee agrees to assume liability for and to save and hold harmless RCTC from and against any and all injuries to any person, including wrongful death, and damage to property, including without limitation, property of or managed by RCTC and Licensee, and all related expenses, including without limitation attorneys' fees, investigators' fees and litigation expenses, resulting in whole or in part from Licensee's failure to comply with any Hazardous Materials Standards issued by any governmental authority concerning Hazardous Materials handled, transported, or disposed on the Licensed Property. Licensee, at its cost, shall assume the defense of all claims, in accordance with Section 15 hereof. Licensee agrees to reimburse RCTC for all costs of any kind incurred as a result of Licensee's failure to comply with this Section, including fines, penalties, clean-up and disposal costs, and legal costs incurred as a result of Licensee's handling, transporting, or disposing of Hazardous Materials on the Licensed Property.

C. Inapplicability. It is understood and agreed that a person or entity who does not now, or in the future, generate, handle, transport, treat, store or dispose of Hazardous Materials on the Licensed Property is not subject to the provisions of this Section.

D. Retained Liabilities. RCTC shall retain all liability under all Environmental Laws asserted at any time in connection with any set of facts or conditions existing in, on or about the Licensed Property prior to the Effective Date of this Agreement arising from and during RCTC's ownership or use of the Licensed Property (hereinafter referred to as "Retained Environmental Liabilities"). For purposes of this Agreement, "Environmental Laws" shall mean all federal, state or local statutes, regulations, ordinances, codes or rules

as such have been or may hereafter be enacted, adopted, amended or supplemented and all common law causes of action relating to the protection of human health or the environmental, including without limitations the Comprehensive Environmental Response, Compensation and Liability Act of 1980, as amended (42 U.S.C. Section 9601 et seq.), the Resource Conservation and Recovery Act, as amended (42 U.S.C. Section 6901 et seq.), the Federal Water Pollution Control Act, as amended (33 U.S.C. Section 7401, et seq.), the Toxic Substance Control Act, as amended (15 U.S.C. 2601, et seq.), the Safe Drinking Water Act, as amended (42 U.S.C. Section 300f, et seq.), the Federal Insecticide, Fungicide and Rodenticide Act, as amended (7 U.S.C. Section 136, et seq.), the Clean Air Act, as amended (42 U.S.C. 7401, et seq.), and other private rights of action for nuisance or damages to property or persons as a result of the presence of Hazardous Materials (as defined above).

6. Fees. N/A

7. Permits. Without limiting the generality of any other provision hereunder, Licensee, at its sole cost and expense, shall obtain and shall comply with any and all permits which may be required by any law, regulation or ordinance for any activities Licensee desires to conduct or have conducted pursuant to this Agreement.

8. Construction; Maintenance and Repair.

A. Licensee may install the Future Improvements in accordance with the plans approved by RCTC, and in accordance with this Section 8. Any deviation from the plans shall be approved in writing by the RCTC's Executive Director or his or her designee.

The Facility and any Future Improvements shall be maintained, at all times, in good condition and repair. Any Facility repair or maintenance work or repair and maintenance of any Future Improvements shall be done at Licensee's sole cost and expense. Maintenance and repair obligations shall include, but not be limited to, graffiti removal, upkeep and replacement of lighting for signage, re-painting of the Facility, and maintenance of asphalt, concrete, sidewalk, and landscaping included as part of the Facility.

B. Licensee shall, at its own cost, install the Future Improvements, at its election, and repair and maintain the Facility, and any Future Improvements, as reasonably necessary, so that the Facility, any Future Improvements and the Licensed Property will not at any time be a source of danger to or unreasonable interference with the RCTC Property (which may include present or future tracks and roadbed), or the safe operation of any activities on the RCTC Property. Any installation, repair and maintenance work shall be done to the Standards (defined below). Licensee shall provide RCTC no less than three (3) days written notice and shall acquire all necessary approvals from RCTC prior to Licensee's commencement of any such repair or maintenance work, provided that minor maintenance activities such as graffiti removal shall only require one (1) days prior written notice. Licensee shall notify RCTC's Property Agent at (951) 787-7141, at least thirty (30) days prior to commencing installation of any Future Improvements.

C. Licensee shall comply with its obligations in this Section to RCTC's reasonable satisfaction. If, at any time, Licensee shall, in the judgment of RCTC, fail to perform properly its obligations under this Section, RCTC may, at its option, after providing Licensee with written notice and thirty (30) days to cure, unless such failure poses an immediate threat to persons or property, or unless a shorter period is specified in this Agreement, perform such work itself as it deems necessary for the safe operation and use of the RCTC Property. In such event, Licensee agrees to pay, within thirty (30) days after a bill is rendered therefor, the cost so incurred by RCTC. However, failure on the part of RCTC to perform the obligations of Licensee shall not release Licensee from liability hereunder for any loss or damage occasioned thereby.

9. Standards. Licensee shall comply with all applicable statutes, ordinances, rules, regulations, orders and decisions (hereinafter referred to as "Standards") issued by any federal, state or local governmental body or agency ("Agency") relating to Licensee's use of the Licensed Property hereunder. In its use of the Licensed Property, Licensee shall at all times be in full compliance with all Standards, present or future, set by any Agency, including, but not limited to, Standards concerning air quality, water quality, noise, and Hazardous Materials. In the event Licensee fails to be in full compliance with Standards set by any Agency, RCTC may, but shall not be obligated to, after giving notice of the failure to Licensee, and if Licensee, within fifteen (15) days following receipt of such notice (unless such period is extended by RCTC), fails to correct such non-compliance, take whatever action it determines in its sole discretion to be necessary to protect the RCTC Property. Licensee shall reimburse the RCTC for all costs (including but not limited to, consulting, engineering, clean-up and disposal, and legal costs) incurred by the RCTC as a result of the Licensee's failure to comply with such Standards, and also such costs incurred by the RCTC in abating a violation of such Standards, protecting against a threatened violation of such Standards, defending any claim of violation of such Standards in any proceeding before any Agency or court, and paying any fines or penalties imposed for such violations. Licensee shall, to the extent permitted by law, assume liability for and shall save and hold harmless the RCTC from any claim of a violation of the Standards regardless of the nature thereof or the Agency or person asserting such claim, which results from Licensee's use of the Licensed Property in violation of the Standards, even if such claim arises in whole or in part from the negligence or alleged negligence of the RCTC. Licensee, at its cost, shall assume the defense of all such claims as provided for in Section 15 hereof.

10. Tests and Inspections. RCTC shall have the right at any time to inspect the Licensed Property, the Facility and any Future Improvements so as to monitor compliance with this Agreement. If, in RCTC's judgment, any condition of the Licensed Property may have an adverse effect on the RCTC Property (whether or not owned by RCTC) or RCTC's operations, RCTC shall be permitted to conduct any tests or assessments, including but not limited to environmental assessments, of, on or about the Licensed Property, the Facility and any Future Improvements, as it determines to be necessary or useful to evaluate the condition of the Licensed Property, the Facility and any Future Improvements. Licensee shall cooperate with RCTC in any tests or inspections deemed necessary by RCTC. Where RCTC tests or evaluations pursuant to this Section reveal that activities of the Licensee have caused adverse effect or injury RCTC property, Licensee shall pay or

reimburse RCTC, as appropriate, for all reasonable costs and expenses incurred due to the tests, inspections or any necessary corrective work and inspections thereafter within thirty (30) days of a request for payment.

11. **Insurance.** Licensee, at its sole cost and expense, shall obtain and maintain, and require its contractors and subcontractors to obtain and maintain, in full force and effect insurance as required by RCTC in the amounts and coverage specified and issued by insurance companies as described on **Exhibit "D"**. RCTC reserves the right, to review and change the amount and type of insurance coverage it requires in connection with this Agreement or the work to be performed on the Facility or for any Future Improvements. Prior to (i) entering the Licensed Property (ii) performing any work or maintenance on the Facility or (iii) installing or performing any work or maintenance of any Future Improvements, Licensee shall furnish RCTC with the insurance endorsements and certificates in the form and amounts specified in **Exhibit "D"**, evidencing the existence, amounts and coverage of the insurance required to be maintained hereunder. In most instances, RCTC does not allow self-insurance, however, if Licensee can demonstrate assets and retention funds meeting RCTC's self-insurance requirements, RCTC may permit Licensee to self-insure; provided, however, that the right to self-insure with respect to any coverage required to be maintained hereunder may be granted or revoked by RCTC in its sole and absolute discretion. RCTC shall not be liable for the payment of any premiums or assessments for insurance required to be maintained by Licensee under this Agreement.

12. **Subordinate Rights.** This Agreement is subject and subordinate to the prior and future rights and obligations of RCTC, its successors and assigns, to use its property in the exercise of its powers and in the performance of its duties, including those as a County Transportation Commission and a member of the Southern California Regional Rail Authority. Accordingly, there is reserved and retained unto RCTC, its successors, assigns and permittees, the right to construct, reconstruct, maintain and use existing and future rail tracks, facilities and appurtenances and existing and future transportation, communication, pipeline facility and other facilities and appurtenances in, upon, over, under, across and along the Licensed Property, and in connection therewith, the right to grant and convey to others, rights and interests to the Licensed Property, including, but not limited to, the right to grant future utility licenses and easements, in, on and around the Licensed Property. This Agreement is subject to all licenses, leases, easements, restrictions, conditions, covenants, encumbrances, liens, claims and other matters of title (hereinafter referred to as "**Title Exceptions**") which may affect the Licensed Property now or hereafter, and the words "**grant**" or "**convey**" as used herein shall not be construed as a covenant against the existence of any such Title Exceptions. If applicable, this Agreement is also subordinate to the Shared Use Agreement executed between the RCTC and Santa Fe dated as of October 30, 1992 and any subsequent amendments thereto.

13. **Indemnity.** Licensee shall at all times indemnify and save harmless RCTC and its subsidiaries, officials, officers, employees, agents, contractors, successors and assigns (the "**Indemnitees**") against and pay in full all losses, damages, or expenses that the Indemnitees may sustain, incur or become liable for, resulting in any manner from the maintenance, repair, reconstruction, alteration, removal, condition or presence of the

Facility or any Future Improvements (including the installation thereof) or the use and maintenance of the Licensed Property by the Licensee, Licensee's Parties or any person or entity claiming, using or occupying the Licensed Property by, under or through Licensee, or anyone directly or indirectly employed by or for whose acts Licensee is liable, including, but not limited to, any such losses, damages or expenses arising out of (a) loss of or damage to property, (b) injury to or death of persons, (c) mechanics' or other liens of any character, (d) taxes or assessments of any kind, or (e) interference with the use of the RCTC's tracks. It is the intention of the Parties that RCTC's right to indemnity hereunder shall be valid and enforceable against Licensee regardless of negligence (whether active or passive) on the part of the Indemnitees, unless such injury is a result of the sole negligence of RCTC.

14. Assumption of Risk and Waiver. To the maximum extent allowed by law, Licensee assumes any and all risk of loss, damage or injury of any kind to any person or property, including without limitation, the Facility, any Future Improvements or appurtenances, if any, the RCTC Property and any other property of, or under the control or custody of, Licensee, which is on or near the Facility or any Future Improvements and the railroad tracks owned or managed by RCTC. Licensee's assumption of risk shall include, without limitation, loss or damage caused by defects in any structure or improvement on the Licensed Property, accident or fire or other casualty on the Licensed Property, or electrical discharge, and noise or vibration resulting from RCTC's transit operations on or near the Licensed Property, if applicable. The term "RCTC" as used in this Section shall include: (i) any transit or rail-related company operating upon or over RCTC's tracks or other property, and (ii) any other persons or companies employed, retained or engaged by RCTC. Licensee, on behalf of itself and its Personnel, as a material part of the consideration for this Agreement, hereby waives all claims and demands against RCTC for any such loss, damage or injury of Licensee and/or its Personnel. In that connection, Licensee waives, for itself and its Personnel, the benefit of California Civil Code Section 1542, which provides as follows:

A general release does not extend to claims which the creditor does not know or suspect to exist in his or her favor at the time of executing the release, which if known by him or her must have materially affected his or her settlement with the debtor.

The provisions of this Section and of Sections 13 and 15 shall survive the termination of this Agreement. As used in this Section, "Personnel" means the Licensee, or its officers, directors, affiliates, or anyone directly or indirectly employed by Licensee or for whose acts Licensee is liable.

15. Defense. Upon written notice from RCTC, Licensee agrees to assume the defense of any lawsuit, administrative action or other proceeding brought against the Indemnitees by any public body, individual, partnership, corporation, or other legal entity, relating to any matter covered by this Agreement for which Licensee has an obligation to assume liability for and/or to indemnify or save and hold harmless the Indemnitees. Licensee shall pay all the costs incident to such defense, including, but not limited to, attorneys' fees, investigators' fees, litigation expenses, settlement payments, and amounts paid in satisfaction of judgments. Any and all lawsuits or administrative actions brought or

threatened on any theory of relief available at law, in equity or under the rules of any administrative agency shall be covered by this Section, including, but not limited to, the theories of intentional misconduct, negligence, breach of statute or ordinance, or upon any theory created by statute or ordinance, state or federal.

16. **Attorneys' Fees.** In any judicial or arbitration proceeding involving performance under this Agreement, or default or breach thereof, the prevailing party shall be entitled to its reasonable attorneys' fees and costs.

17. **Successors and Assigns.** All the covenants and provisions of this Agreement shall be binding upon and inure to the benefit of the successors, legal representatives and assigns of the RCTC and Licensee to the same extent and effect as the same are binding upon and insure to the benefit of the Parties hereto.

18. **Survival of Obligations.** All obligations of Licensee hereunder not fully performed as of the termination or cessation of this Agreement in any manner shall survive the termination of this Agreement, including without limitation, all payment obligations with respect to fees and all obligations concerning the condition of the Facility, any Future Improvements and the RCTC Property.

19. **Assignment.** This Agreement and the license granted herein are personal to the Licensee. Licensee shall not assign or transfer (whether voluntary or involuntary) this Agreement in whole or in part, or permit any other person or entity to use the rights or privileges hereby conveyed, without the prior written consent of RCTC, which may be withheld in RCTC's sole and absolute discretion. Any attempted act in violation of this Section shall be void and without effect and give RCTC the right to immediately terminate this Agreement.

20. **Waiver of Covenants or Conditions.** The waiver by RCTC of the performance of any covenant or condition under this Agreement shall not invalidate this Agreement nor shall it be considered a waiver by it of any other covenant or condition under this Agreement.

21. **Amendment.** This Agreement may be amended at any time by the written agreement of RCTC and Licensee. All amendments to this Agreement shall be binding upon the Parties despite any lack of legal consideration, so long as the same shall be in writing and executed by the Parties hereto.

22. **Revocation.** If, at any time, Licensee shall fail or refuse to comply with or carry out any of the covenants herein contained, RCTC may, at its election, immediately revoke and terminate this Agreement unless a longer notice period is specifically provided for elsewhere in this Agreement.

23. **Eviction, Abandonment or Sale.** In the case of the eviction of Licensee by anyone owning or obtaining title to the premises on which the Facility and any Future Improvements are located, or the sale or abandonment by RCTC of said premises, RCTC shall not be liable to Licensee for any damage of any nature whatsoever or to refund any payment made by Licensee to RCTC hereunder.

24. **Condemnation.** In the event all or any portion of the Licensed Property shall be taken or condemned for public use, this Agreement shall terminate and any commission or damages arising out of such taking or condemnation, if any, awarded to Licensee are hereby assigned by Licensee to RCTC.

25. **Revocable Licenses and Termination.** Licensee agrees that notwithstanding any sums expended by Licensee in furtherance of this Agreement, the license granted herein is revocable and may be terminated by RCTC in accordance with the terms of this Agreement.

26. **Notice.** Any notice hereunder to be given by RCTC to Licensee shall be deemed to be properly served on the date it is deposited in the United States Mail, postage prepaid, addressed to such party at its address set forth in the Basic License Provisions. Either RCTC or Licensee may change its address for the receipt of notice by giving written notice thereof to the other party of such change. Notices shall be effective on the date delivered to custody of the U.S. Postal Service.

27. **Interest on Past-due Obligations.** Except as expressly herein provided, any amount due to RCTC which is not paid when due shall bear interest, from the date due, at the rate of ten percent (10%) per annum. Such interest will be due RCTC as it accrues. Payment of such interest shall not excuse or cure any default by Licensee under this Agreement, provided, however, that interest shall not be payable on late charges incurred by Licensee.

28. **Nondiscrimination.** Licensee certifies and agrees that all persons employed thereby and/or the affiliates, subsidiaries, or holding companies thereof and any contractors retained thereby with respect to the Licensed Property, the Facility and any Future Improvements are and shall be treated equally without regard to or because of race, religion, ancestry, national origin, or sex, and in compliance with all federal and state laws prohibiting discrimination in employment, including but not limited to the Civil Rights Act of 1964; the Unruh Civil Rights Act; the Cartwright Act; and the California Fair Employment Practices Act.

29. **Liens.** Licensee shall not suffer or permit to be filed or enforced against the RCTC Property, the Facility, any Future Improvements, or any part thereof, any mechanics', materialmen's, contractors', or subcontractors' liens or stop notices arising from, or any claim for damage growing out of Licensee's use of the Licensed Property hereunder. Licensee shall pay or cause to be paid all such liens, claims or demands, including sums due with respect to stop notices, together with attorneys' fees incurred by RCTC with respect thereto, within ten (10) business days after notice thereof and shall indemnify, hold harmless and defend RCTC from all obligations and claims made against RCTC for and with respect to the above described work, including attorneys' fees. Licensee shall furnish evidence of payment upon request of RCTC. Licensee may contest any lien, claim or demand by furnishing a statutory lien bond or equivalent with respect to stop notices to RCTC in compliance with applicable California law. If Licensee does not discharge any mechanic's lien or stop notice for works performed for Licensee, RCTC shall have the right to discharge same (including by paying the claimant) and Licensee shall reimburse RCTC for the cost of such discharge within ten (10) business days after billing. RCTC reserves

the right at any time to post and maintain on the RCTC Property such notices as may be necessary to protect RCTC against liability for all such liens and claims. The provisions of this Section shall survive the termination of this Agreement.

30. Further Acts. Licensee agrees to perform any further acts and to execute and deliver in recordable form any documents which may be reasonably necessary to carry out the provisions of this Agreement, including, at RCTC's sole discretion, the relocation of the Facility, any Future Improvements and the license granted by this Agreement.

31. Waiver of Relocation Rights. LICENSEE HEREBY WAIVES ANY RIGHT TO RELOCATION ASSISTANCE, MOVING EXPENSES, GOODWILL OR OTHER PAYMENTS TO WHICH LICENSEE MIGHT OTHERWISE BE ENTITLED, BUT FOR THIS WAIVER AND RCTC'S EXPRESS RIGHT OF TERMINATION, UNDER THE UNIFORM RELOCATION ASSISTANCE AND REAL PROPERTY ACQUISITION POLICIES ACT OF 1970, AS AMENDED, 42 UNITED STATE CODE SECTION 4601 ET SEQ. AND/OR THE CALIFORNIA RELOCATION ASSISTANCE LAW, AS AMENDED, GOVERNMENT CODE SECTION 7260 ET SEQ.

32. Non-Exclusive License. The license granted by this Agreement is not exclusive and RCTC specifically reserves the right to grant other licenses within the vicinity of the Facility and any Future Improvements, provided that RCTC and Licensee shall meet and confer to resolve any potential conflicts with Licensee's Project.

33. Counterparts; Facsimile Signatures. This Agreement may be executed in one or more counterparts, each of which shall be deemed an original but all of which together shall constitute one and the same instrument. Facsimile signatures shall be considered original signatures.

34. Severability. If any term, covenant, condition or provision of this Agreement, or the application thereof to any person or circumstance, shall to any extent be held by a court of competent jurisdiction to be invalid, void or unenforceable, the remainder of the terms, covenants, conditions, or provisions of this Agreement, or the application thereof to any person or circumstance, shall remain in full force and effect and shall in no way be affected, impaired or invalidated thereby.

35. Captions. The Captions included in this Agreement are for convenience only and in no way define, limit, or otherwise describe the scope or intent of this Agreement or any provision hereof, or in any way affect the interpretation of this Agreement.

36. Time of Essence. Time is of the essence in this Agreement.

37. No Recording. Licensee shall not record or permit to be recorded in the official records of the county where the Licensed Property is located any memorandum of this Agreement or any other document giving notice of the existence of this Agreement or the license granted hereby.

38. Entire Agreement. This Agreement and the Exhibits hereto constitute the entire agreement between the RCTC and Licensee with respect to the subject matter hereof and

supersede all prior verbal or written agreements and understandings between the parties with respect to the items set forth herein.

39. Incorporation of Recitals. The Recitals set forth above are true and correct and are incorporated into this Agreement by reference as though fully set forth herein.

40. Governing Law. This Agreement shall be governed by the laws of the State of California. Venue shall be in Riverside County.

[SIGNATURES ON FOLLOWING PAGE]

**SIGNATURE PAGE
TO
LICENSE AGREEMENT NO. 15-33-007-00**

IN WITNESS WHEREOF, the Parties have executed this Agreement in duplicate the day and year first above written.

**RIVERSIDE COUNTY TRANSPORTATION
COMMISSION**

CITY OF PERRIS

By: _____
Anne Mayer, Executive Director

By: _____

Its: _____

APPROVED AS TO FORM:

ATTEST:

By: _____
Best Best & Krieger LLP
Counsel to the Riverside County
Transportation Commission

By: _____
City Clerk

APPROVED AS TO FORM:

By: _____
City Attorney

EXHIBIT "A"

DESCRIPTION OF LICENSED PROPERTY

Those portions of RCTC property shaded in gray on the four (4) attached pages, and within the "license boundary" as identified in the data tables of said pages.

[attached behind this page]

Exhibit "A"

3/24/08 PM 4:58 PM 4:58 PM - berrad
 G:\Projects\4013703\4013703_0001\Drawings\City\Exhibits\20030802_Perris-Stop-Maintenance-Areas\02_Monument_Sign-2.dwg
 G:\City\Standards\SCRRAS\Standards\Plan\Tables\Plan\STemp.tbl
 G:\City\Standards\SCRRAS\Standards\Plan\Tables\Plan\STemp.tbl
 G:\City\Standards\SCRRAS\Standards\Plan\Tables\Plan\STemp.tbl

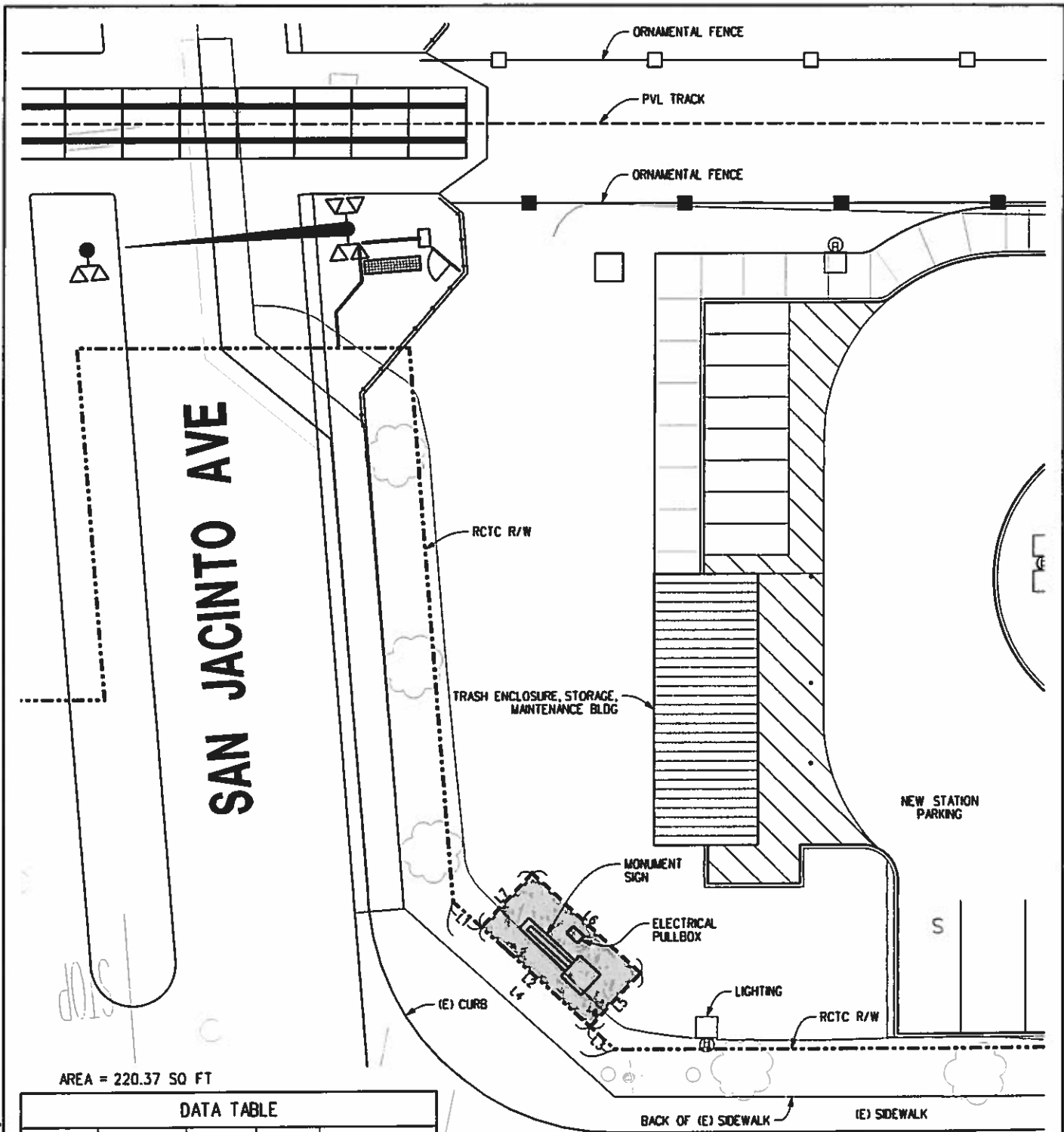

AREA = 220.37 SQ FT

DATA TABLE				
DATA NO.	Δ/BEARING	R	L	DESCRIPTION
L1	N47° 39' 39" E	-	5.43'	RCTC R/W
L2	N47° 39' 39" E	-	21.00'	RCTC R/W
L3	N47° 39' 39" E	-	4.76'	RCTC R/W
L4	N47° 39' 39" E	-	31.18'	RCTC R/W
L5	N42° 05' 11" W	-	10.45'	LICENSE BOUNDARY
L6	N47° 54' 49" E	-	21.00'	LICENSE BOUNDARY
L7	N42° 05' 11" W	-	10.54'	LICENSE BOUNDARY



RIVERSIDE COUNTY TRANSPORTATION COMMISSION
STV Incorporated
ENGINEERS, ARCHITECTS, PLANNERS, CONSTRUCTION MANAGERS
 8130 INVERMERE PLACE, SUITE 310
 RANCHO CUCAMONCA, CA 91730-8540

RCTC PERRIS VALLEY LINE
DOWNTOWN PERRIS STATION E
MONUMENT SIGN 2 - SAN JACINTO AVE & C STREET

D STREET

6TH STREET

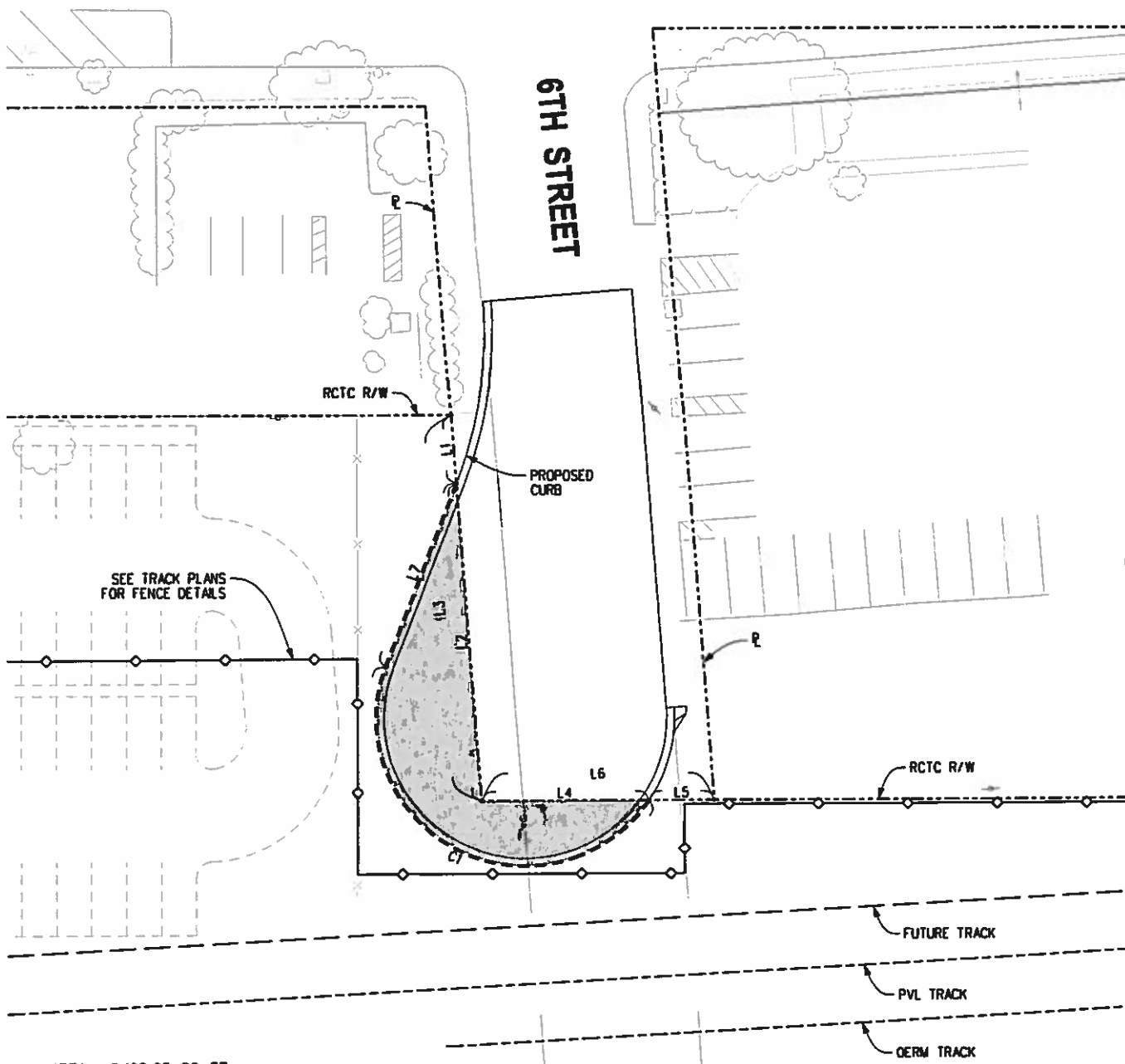

AREA = 2,128.05 SQ FT

DATA TABLE

DATA NO.	Δ/BEARING	R	L	DESCRIPTION
L1	N89° 38' 30" W	-	17.69'	RCTC R/W
L2	N89° 38' 30" W	-	82.63'	RCTC R/W
L3	N89° 38' 30" W	-	100.32'	RCTC R/W
L4	N04° 57' 28" E	-	43.25'	RCTC R/W
L5	N04° 57' 28" E	-	16.95'	RCTC R/W
L6	N04° 57' 28" E	-	60.20'	RCTC R/W
L7	N64° 06' 42" W	-	50.90'	LICENSE BOUNDARY
C1	S66° 15' 42" W	38.50'	111.72'	LICENSE BOUNDARY

8/2/2013 3:42:40 PM USER = barcord C:\Users\barcord\Documents\Projects\20130802_Perris-Stop-Maintenance-Access\04_West-6th-Street.dwg
 C:\ProgramData\Autodesk\LTWorkspaces\2013\USA\English\PlotStyle\mon.ctb
 C:\Users\barcord\AppData\Local\Temp\Autodesk\LTWorkspaces\2013\USA\English\PlotStyle\mon.ctb

RCTC RIVERSIDE COUNTY TRANSPORTATION COMMISSION

STV Incorporated
 ENGINEERS ARCHITECTS PLANNERS CONSTRUCTION MANAGERS
 9150 RAVENHILL PLACE, SUITE 210
 RANCHO CUCAMONCA, CA 91730-8540

**RCTC PERRIS VALLEY LINE
 DOWNTOWN PERRIS STATION E**
 6TH STREET

EXHIBIT "B"

HAZARDOUS MATERIALS ALLOWANCES

The Parties acknowledge and agree that RCTC is not providing an exception for any Hazardous Material. As such, Licensee shall not cause or permit, or allow any of Licensee's Parties to cause or permit, any Hazardous Materials to be brought upon, stored, used, generated, handled, transported, treated or disposed of on or about the RCTC Property.

Exhibit "B"

EXHIBIT "C"

The items below are attached behind this Exhibit "C", as Exhibits C1 through C8, and are incorporated herein by reference.

- C1. Maintenance Area- Station Identification Monument Sign: SE corner of San Jacinto and C Street.
- C2. Maintenance Area- Station Identification Monument Sign: NE corner of 4th and C Streets.
- C3. Station Identification Sign Construction Details: E-L-501 and E-L-503.
- C4. Maintenance Area- 2nd Street Pedestrian Paseo (east of rail).
- C5. 2nd Street Pedestrian Paseo Construction Details: E-L-001 and E-L-402.
- C6. 2nd Street Pedestrian Paseo Future Decorative Lights Construction Details
- C7. Maintenance Area- Cul-De-Sac Improvements at 6th Street (east of rail).
- C8. Cul-De-Sac Improvements at 6th Street Construction Detail: E-W-281.

Prior to the Commencement Date, or as soon thereafter as possible, RCTC shall provide as-built drawings and PVL contractor submittals relevant to the items below to the City for its files.

Summary of items that the City of Perris shall maintain at the following locations:

- Primary station identification monument sign: SE c/o San Jacinto and C Street.
 - *Reference design drawings Exhibits C1 and C3*
 - Station identification sign and monument tower.
 - Electrical conduit and wiring between the pull box and sign, and the electrical components of the physical sign.
- Primary station identification monument sign: NE c/o 4th and C Streets.
 - *Reference design drawings Exhibits C2 and C3*
 - Station identification sign and monument tower.
 - Electrical conduit and wiring between the pull box and sign, and the electrical components of the physical sign..
- Pedestrian paseo along 2nd Street, east of rail.
 - *Reference design drawings Exhibits C4, C5 and C6*
 - Colored concrete.
 - Decorative stamped walkway.
 - Three (3) future decorative lights, including power from the city service pedestal
 - Future pavers.
 - Future trees.
- Cul-de-sac improvements at 6th Street, east of rail.
 - *Reference design drawing Exhibit C8*
 - Concrete curb and gutter.
 - Asphalt paving.
 - Future sidewalk.
 - Future parkway improvements, including landscaping.

The items indicated above as "future" shall not be considered part of the "Facility", as that term is used in the Agreement, and shall instead be referred to as the "Future Improvements".

The Parties agree that the City, and not RCTC, shall be responsible for any installation of the Future Improvements, at City's election, as further set forth in the Agreement, and for maintenance and repair of all Future Improvements.

Exhibit "C"

For clarification, RCTC is the Party responsible for supplying power to the sign pull boxes, and for maintaining its own irrigation system and landscaping. The City is responsible for maintaining the electrical conduit and wiring between the pull boxes and each sign, and for the electrical components of the physical signs. The City is also responsible for maintaining each sign, as well as for the maintenance and repair of the other items listed in this **Exhibit "C"**.

[plans to be attached]

Exhibit "C"

EXHIBIT C-2

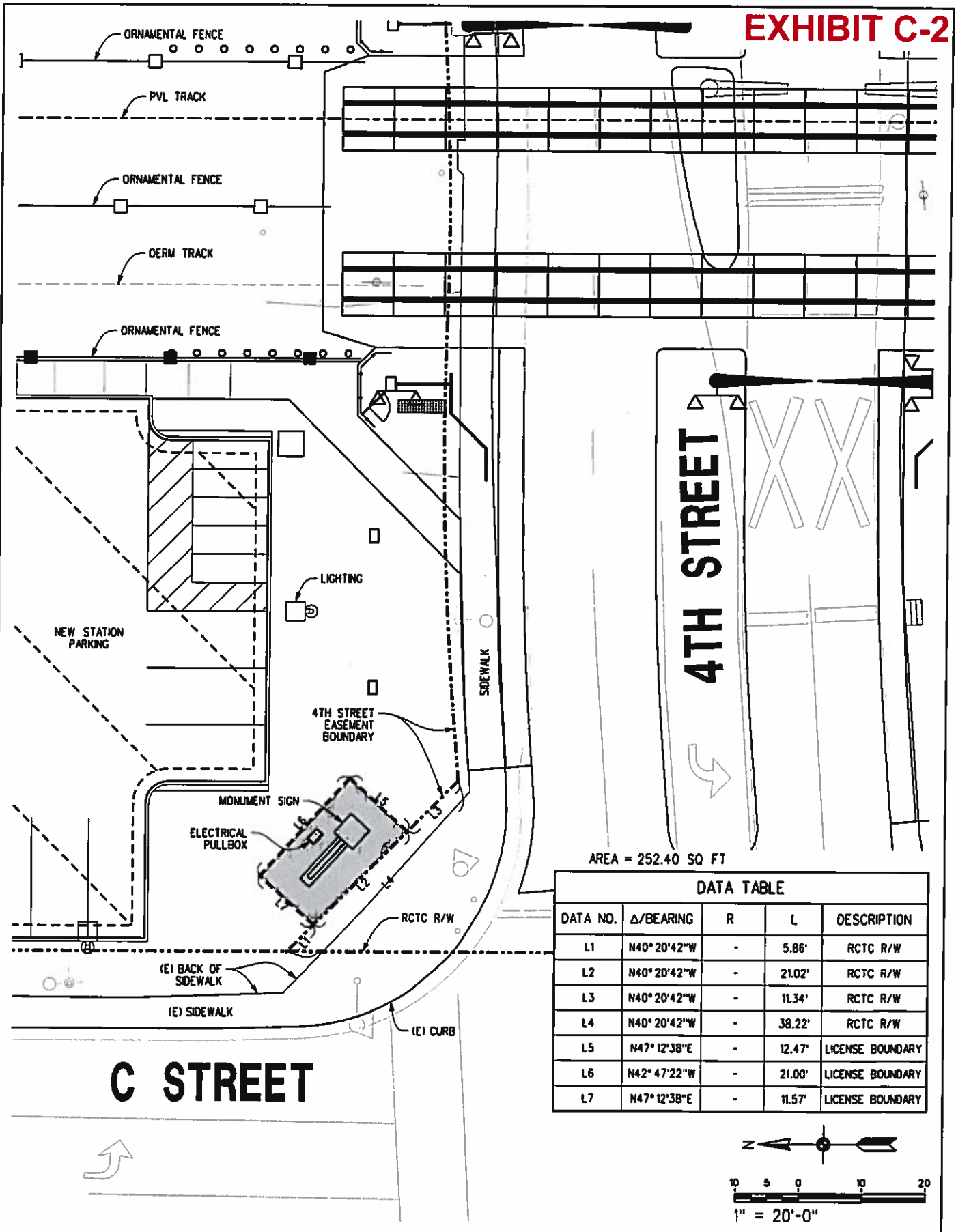

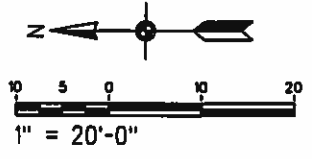

AREA = 252.40 SQ FT

DATA TABLE				
DATA NO.	Δ/BEARING	R	L	DESCRIPTION
L1	N40°20'42"W	-	5.86'	RCTC R/W
L2	N40°20'42"W	-	21.02'	RCTC R/W
L3	N40°20'42"W	-	11.34'	RCTC R/W
L4	N40°20'42"W	-	38.22'	RCTC R/W
L5	N47°12'38"E	-	12.47'	LICENSE BOUNDARY
L6	N42°47'22"W	-	21.00'	LICENSE BOUNDARY
L7	N47°12'38"E	-	11.57'	LICENSE BOUNDARY



8/5/2015 3:28:45 PM USGS - barraz
 E:\Projects\4013701\4013703_000\Drawings\Plan\Station\Sign-Light
 D:\Cad\Software\SCORRA\Standard\Plan\Station\Sign-Light
 G:\Cad\Software\SCORRA\Standard\Plan\Station\Sign-Light

RIVERSIDE COUNTY TRANSPORTATION COMMISSION

STV Incorporated
ENGINEERS/ARCHITECTS/PLANNERS/CONSTRUCTION MANAGERS
 9130 ANAHEIM PLACE, SUITE 210
 RANCHO CUCAMONCA, CA 91730-8540

**RCTC PERRIS VALLEY LINE
 DOWNTOWN PERRIS STATION E
 MONUMENT SIGN 1 - 4TH STREET AND C STREET**

GENERAL NOTES

1. CITY SEAL TO BE 3/4" DIAMETER & 1/2" THICK. ALUMINUM WITH FAULT BRIDGE PART TREATMENT SEAL WITH HORIZONTAL BRUSHED SATIN FINISH AND CLEAR COAT PROTECTIVE LAYER TO PREVENT OXIDATION. PLACE TO BE INSTALLED FUSION AND CEMENTED IN WALL USING STONE AND ADHESIVE AS REQUIRED PER MANUFACTURER'S DIRECTIONS. CONTACT CITY OF PERRIS FOR CITY SEAL. ANY WORK FROM INCIDENT ENGINEER. SUBMIT FULL SIZE SHOP DRAWING FOR REVIEW AND APPROVAL BY RESIDENT ENGINEER.

2. CLEANED STONE VENEER BY QUOTE COMPANY. INSTALL PER MANUFACTURER'S DIRECTIONS. MATCH STONE PATTERN OF MONUMENTATION SIGN COLUMN @ STREET AND SAN JACINTO.

3. CONTRACTOR TO SUBMIT FULL SIZE WORK SHOP DRAWING FOR APPROVAL BY RESIDENT ENGINEER & LANDSCAPE ARCHITECT PRIOR TO FABRICATING MATERIALS AND WORKMAN TO BE COMPLETED BY STRUCTURAL ENGINEER.

4. REFER TO STRUCTURAL ENGINEER'S PLANS FOR FOUNDATION AND NON-STRUCTURAL ENGINEERING INFORMATION SHEET E 5-002 & E 5-001.

5. APPLY WOODEN ANTI-CRAACKING SYSTEM TO SIGN WALLS AND CURB PLANTING PER MANUFACTURER'S DIRECTION. BETHELL, INC. 800-338-5200. INSTALL PER MANUFACTURER'S DIRECTIONS. MATERIALS POLYESTER FILLER - CLEAR. POLYESTER POLYURETHANE CLEAR COATING.

6. REFER TO MONUMENT SIGN DETAILS SHEETS SO-500 FOR ADDITIONAL INFORMATION.

7. PRECAST CONCRETE MANUFACTURED BY QUACKCONCRETE OR APPROVED EQUAL.

8. CONTRACTOR TO PROVIDE SAMPLES FOR APPROVAL BY RESIDENT ENGINEER AND LANDSCAPE ARCHITECT.

a. STONE
b. PRECAST CONCRETE
c. CEMENT
d. LEAN

9. CONTRACTOR TO PREPARE A STONE MOCK-UP FOR APPROVAL BY RESIDENT ENGINEER AND LANDSCAPE ARCHITECT.

MANUFACTURER & SUPPLIER CONTACT INFORMATION
 QUACKCONCRETE: (909) 782-3434
 FURNISH SIGN AND DESIGN: (909) 942-1000
 QUOTE COMPANY: (909) 431-5101
 BETHELL, INC: (800) 338-5200

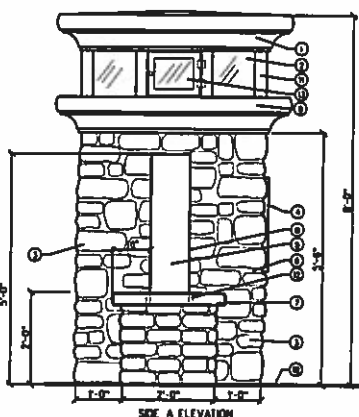

- LEGEND**
- 1 PRECAST CONCRETE CAP - MEDIUM STONED GREY TO MATCH COLOR SAMPLE SUB ON FILE BY CITY OF PERRIS
 - 2 LEAN PANEL - GOLD/YELLOW COLOR CODED BY STRUCT
 - 3 STONE VENEER - SUMNER STREAM STONE CONCRETE BY CULTURED STONE OR APPROVED EQUAL
 - 4 CITY SEAL - ALUMINUM FAULT BRIDGE BY FUSION
 - 5 CONCRETE SIGN BASE PANEL - 1/2" THICK MANUFACTURED BY QUACKCONCRETE
 - 6 GREY MORTAR
 - 7 PRE-CAST CONCRETE WALL - MONTECELLO GREY - FINISH TO MATCH CAP
 - 8 BLACK IMPRINTED LETTERING - ALUMINUM CHARITON WITH BEVELLED EDGES - FRONT STREET SIDE OF SIGN WALL / FINE ADDRESS NUMBER 120
 - 9 FINISH SLOPE TO MATCH CITY OF PERRIS 1/4" TO 1/2" INPA SLL AND CAP FINISH
 - 10 FUSION BRIDGE
 - 11 SUPPORT - 2" SQUARE TUBULAR STEEL
 - 12 MORTAR JOINT
 - 13 ACCESS PANEL - SEE DETAIL SHEET L-500

MONUMENT SIGN WALL - SIDE A ELEVATION
 SCALE: 1" = 1'-0"

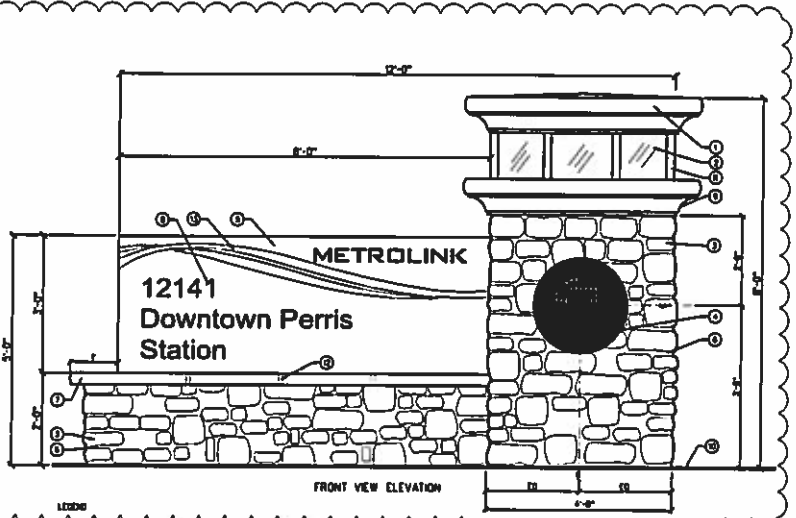

- LEGEND**
- 1 PRECAST CONCRETE CAP - MEDIUM STONED GREY TO MATCH COLOR SAMPLE SUB ON FILE BY CITY OF PERRIS
 - 2 1" LAYER OF CONCRETE OVER EPS ARCHITECTURAL FOAM BOARD MANUFACTURE BY QUACKCONCRETE OR APPROVED EQUAL
 - 3 LEAN PANEL - GOLD/YELLOW - COLOR CODED BY STRUCT
 - 4 STONE VENEER - SUMNER STREAM STONE CONCRETE BY CULTURED STONE OR APPROVED EQUAL
 - 5 CITY SEAL - ALUMINUM FAULT BRIDGE BY FUSION
 - 6 CONCRETE SIGN BASE PANEL - 1/2" THICK - COLOR P3-73 BAC BANGLOW WHITE P3 SANDBLAST
 - 7 GREY MORTAR
 - 8 PRE-CAST CONCRETE WALL - MONTECELLO GREY - FINISH TO MATCH CAP
 - 9 BLACK IMPRINTED LETTERING - ALUMINUM CHARITON WITH BEVELLED EDGES - FRONT STREET SIDE OF SIGN WALL / FINE ADDRESS NUMBER 120
 - 10 FINISH SLOPE TO MATCH CITY OF PERRIS 1/4" TO 1/2" INPA SLL AND CAP FINISH
 - 11 FUSION BRIDGE
 - 12 SUPPORT - 2" SQUARE TUBULAR STEEL
 - 13 MORTAR JOINT
 - 14 GRAPHIC STONES - CAST BATED FACE AND PAINTED - COLORS ARE PMS 300 COY-7500 AND PMS 300-7500-0000. CONTRACTOR TO MOCK-UP SIGN PRIOR TO CONSTRUCTION FOR APPROVAL BY RESIDENT ENGINEER AND LANDSCAPE ARCHITECT

MONUMENT SIGN WALL - FRONT VIEW ELEVATION
 SCALE: 1" = 1'-0"



MONUMENT SIGN WALL KEY PLAN

<p>APPROVED FOR CONSTRUCTION BY:</p> <p>RESIDENT ENGINEER: [Signature]</p> <p>DATE: 10-24-13</p>		<p>RIVERSIDE COUNTY TRANSPORTATION COMMISSION</p> <p>APPROVED FOR CONSTRUCTION BY:</p> <p>DATE: 10-24-13</p>		<p>RCTC PERRIS VALLEY LINE DOWNTOWN PERRIS STATION E MONUMENT SIGN DETAILS SHEET 1 OF 8</p>		<p>PROJECT NO. 12141-DT-1305-001</p> <p>DATE: 10-24-13</p> <p>1308 OF 2595</p> <p>AS NOTED</p>	
<p>MANUFACTURER & SUPPLIER CONTACT INFORMATION</p> <p>QUACKCONCRETE: (909) 782-3434</p> <p>FURNISH SIGN AND DESIGN: (909) 942-1000</p> <p>QUOTE COMPANY: (909) 431-5101</p> <p>BETHELL, INC: (800) 338-5200</p>		<p>STV Incorporated</p> <p>10-24-13</p>		<p>ima</p>		<p>PROJECT NO. 12141-DT-1305-001</p> <p>DATE: 10-24-13</p> <p>1308 OF 2595</p> <p>AS NOTED</p>	

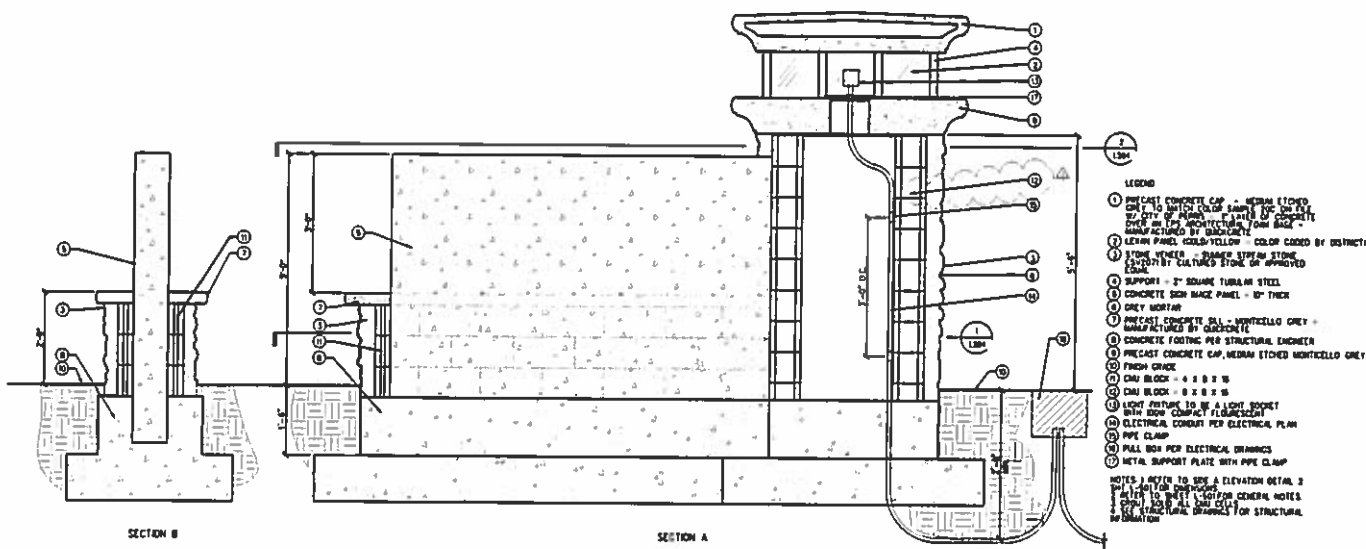

- LEGEND
- ① PRECAST CONCRETE CAP - MEDIUM ETCHED GREY TO MATCH COLOR SAMPLE FOR CITY OF PERRIS. 4" VERTICAL OF CONCRETE MANUFACTURED BY GARDOLITE
 - ② LEXAN PANEL, GOLD/YELLOW - COLOR COATED BY DISTRICT
 - ③ STONE VENEER - RAMMED AGGREGATE STONE FINISH BY CULTURED STONE OR APPROVED EQUAL
 - ④ SUPPORTS - 2" SQUARE TUBULAR STEEL
 - ⑤ CONCRETE SIDE BRACE PANEL - 8" THICK
 - ⑥ GREY MORTAR
 - ⑦ PRECAST CONCRETE SILL - MONTICELLO GREY - MANUFACTURED BY GARDOLITE
 - ⑧ CONCRETE FOOTING PER STRUCTURAL ENGINEER
 - ⑨ PRECAST CONCRETE CAP, MEDIUM ETCHED MONTICELLO GREY
 - ⑩ GRAY BLOCK - 8" x 8" x 8"
 - ⑪ GRAY BLOCK - 8" x 8" x 8"
 - ⑫ LIGHT FIXTURE TO BE A LIGHT SOCKET WITH 80W COMPACT FLUORESCENT BULB
 - ⑬ ELECTRICAL CONDUIT PER ELECTRICAL PLAN
 - ⑭ PIPE CLAMP
 - ⑮ PULL BOX PER ELECTRICAL DRAWINGS
 - ⑯ METAL SUPPORT PLATE WITH PIPE CLAMP
- NOTES: REFER TO SEE AN ELEVATION DETAIL 2 FOR LIGHT FIXTURE COMPONENTS
 REFER TO SHEET C-10 FOR GENERAL NOTES
 CONSULT ALL CITY ORDINANCES
 FOR STRUCTURAL DRAWINGS FOR STRUCTURAL ENGINEER

MONUMENT SIGN WALL SECTION
 SCALE: 1/4" = 1'-0"

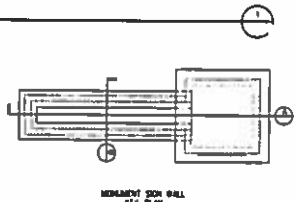

MONUMENT SIGN WALL
 KEY PLAN

DATE: 10/14/11
 DRAWN BY: J. CUTNER
 CHECKED BY: P. MILLS
 APPROVED BY: A. WOODWARD
 PROJECT: RCTC PERRIS VALLEY LINE
 SHEET: 1310 OF 2599

<p>STV Incorporated 10700 Valley Blvd. Suite 100 Van Nuys, CA 91411 (818) 709-1111 www.stvinc.com</p>	<p>RIVERSIDE COUNTY TRANSPORTATION COMMISSION</p>		<p>RCTC PERRIS VALLEY LINE DOWNTOWN PERRIS STATION E MONUMENT SIGN DETAILS SHEET 3 OF 8</p>	<p>DATE: 10/14/11 DRAWN BY: J. CUTNER CHECKED BY: P. MILLS APPROVED BY: A. WOODWARD PROJECT: RCTC PERRIS VALLEY LINE SHEET: 1310 OF 2599 AS NOTED</p>
--	--	--	---	---

COORDINATION & REFERENCE NOTES

SYMBOL	REFERENCE	DESCRIPTION
①		EXISTING SIDEWALK
②		RESTROOM
③		PAINTED PEDESTRIAN CROSSING
④		PEDESTRIAN CROSSING AT TRACK
⑤		PHASE IV FUTURE STATION PLATFORM
⑥		COMMUNICATIONS SHELTER
⑦		LIGHTING
⑧		PROPERTY LINE
⑨		EXISTING UTILITIES
⑩		EXISTING LIGHTING
⑪		TRAIN TRACK
⑫		STATION PLATFORM
⑬		CLUM
⑭		20' LANDSCAPE CLEARANCE LINE
⑮		ELECTRICAL PANEL
⑯		STORM DRAIN INLET
⑰		GUTTER
⑱		CURB RAMP
⑲		RIGHT OF WAY FENCE
⑳		TRASH ENCLOSURE AND STORAGE
㉑		INTERFERENCE FENCE
㉒		BIKE STOP
㉓		STORM DRAIN
㉔		PEDESTRIAN GATE ARM
㉕		STEEL PANE RAIL
㉖		PEDESTRIAN SPRING GATE
㉗		MONUMENT SIGN
㉘		FUTURE FLAG POLES
㉙		SEWAGE



PAVING SCHEDULE

SYMBOL REFERENCE	DESCRIPTION	PATTERN	COLOR	FRESH	JOINT	MANUFACTURE	COMMENTS
[P1]	REFER TO CIVIL DRAWINGS & DETAILS	CONCRETE PAVING	NATURAL GRAY	MEDIUM BROOM	TOOLED		TYPICAL SIDEWALK
[P2]	REFER TO CIVIL DRAWINGS & DETAILS	CONCRETE CURB	NATURAL GRAY	MEDIUM BROOM	TOOLED		
[P3]	REFER TO CIVIL DRAWINGS & DETAILS	CONCRETE PAVING	DAVE TERRA COTTA POLISH	ARAGON EXPOSED AGGREGATE	SAW-CUT		INTEGRAL COLORED CONCRETE. SEE ROAD DEPARTMENT TO SUBMIT SHOP DRAWINGS. SEE ROAD DEPARTMENT FOR APPROVAL BY RESIDENT ENGINEER AND LANDSCAPE ARCHITECT.
[P4]	REFER TO CIVIL DRAWINGS & DETAILS	CONCRETE PAVING	DAVE TERRA COTTA POLISH	MEDIUM BROOM	SAW-CUT		INTEGRAL COLORED CONCRETE
[P5]	REFER TO CIVIL DRAWINGS & DETAILS	CONCRETE PAVING	DAVE TERRA COTTA POLISH	MEDIUM BROOM	SAW-CUT		INTEGRAL COLORED CONCRETE. SEE ROAD DEPARTMENT TO SUBMIT SHOP DRAWINGS. SEE ROAD DEPARTMENT FOR APPROVAL BY RESIDENT ENGINEER AND LANDSCAPE ARCHITECT.
[P6]	REFER TO CIVIL DRAWINGS & DETAILS	CONCRETE PAVING	NATURAL GRAY	MEDIUM BROOM	TOOLED		8" WIDE CONCRETE RIBS

SIGNAGE SCHEDULE

SYMBOL REFERENCE	DESCRIPTION	PATTERN	COLOR	FRESH	MANUFACTURE	COMMENTS
[S1]	REFER TO DETAIL SHEET S01-S04	ENTRY MONUMENT SIGN	PER PLAN	PER PLAN	PER PLAN	PER PLAN

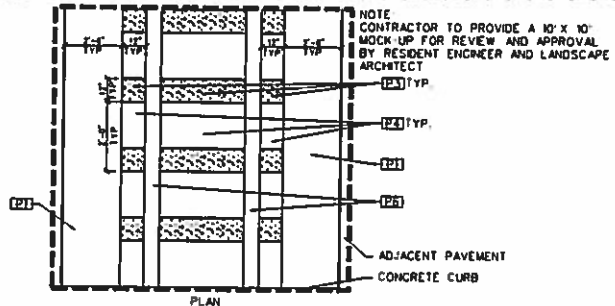

RAILROAD PATTERN CROSSWALK FINISH ENLARGEMENT

SCALE: 1/4" = 1'-0"

RIVERSIDE COUNTY TRANSPORTATION COMMISSION

A. CUTNER
A. MULLS
A. WOODWARD
A. CUTNER
10-24-11

STV Incorporated

ima

RTC PERRIS VALLEY LINE
DOWNTOWN PERRIS STATION E
CONSTRUCTION LEGENDS & NOTES

13-31 PER-11
1-001
1287 OF 2599
NONE

10'-6" SIGN COIL LANDMARK
STATION 241910.100 (PANEL SET)

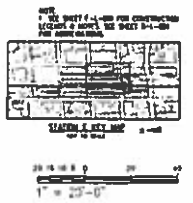
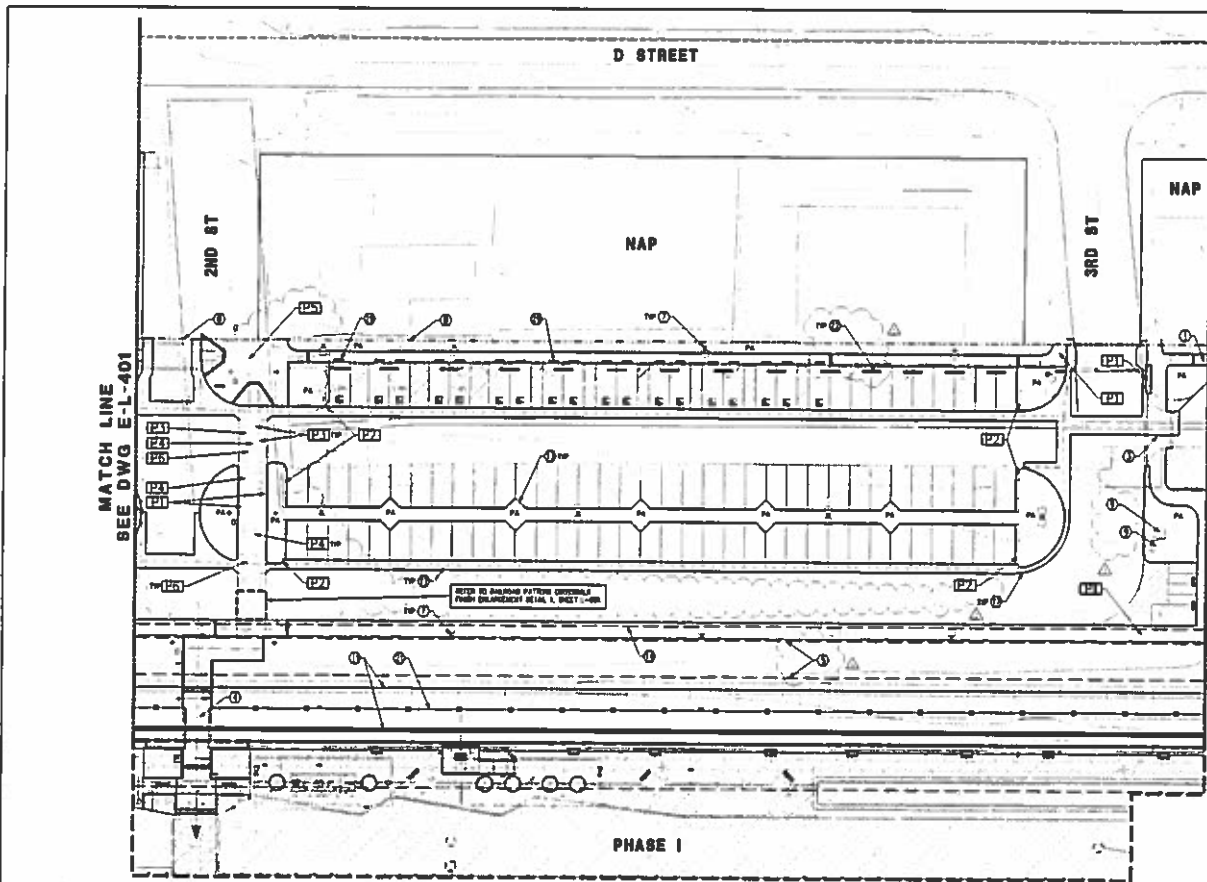

1. THE INFORMATION CONTAINED HEREIN IS THE PROPERTY OF STV INCORPORATED. IT IS TO BE USED ONLY FOR THE PROJECT AND SITE SPECIFICALLY IDENTIFIED HEREIN. IT IS NOT TO BE REPRODUCED, COPIED, OR TRANSMITTED IN ANY FORM OR BY ANY MEANS, ELECTRONIC OR MECHANICAL, INCLUDING PHOTOCOPYING, RECORDING, OR BY ANY INFORMATION STORAGE AND RETRIEVAL SYSTEM, WITHOUT THE WRITTEN PERMISSION OF STV INCORPORATED.

<p> A. CUTNER A. MILLS A. WOODWARD A. CUTNER </p>	<p> RCTC RIVERSIDE COUNTY TRANSPORTATION COMMISSION </p>	<p> STV Incorporated </p>	<p> ima </p>		<p> RCTC PERRIS VALLEY LINE DOWNTOWN PERRIS STATION E CONSTRUCTION PLAN SHEET 3 OF 4 </p>	<p> 123456789 1234 6P 2598 1" = 20' </p>
--	---	---	--	--	--	--

LIGHTING FIXTURE SCHEDULE



LIGHTING FIXTURE SCHEDULE

EXHIBIT C-6

TYPE	DESCRIPTION	LAMP DATA			MANUFACTURER AND CATALOG NUMBER	TYPE	DESCRIPTION	LAMP DATA			MANUFACTURER AND CATALOG NUMBER	MODEL		
		QTY	TYPE	WATT				QTY	TYPE	WATT				
A	NOT USED	1	F094 15 48	24	377		L8	RECREATING SUN VALLEY LIGHT FIXTURE AND POLE TO MATCH STA TRANSIT CENTER PHASE 1 PROCESSION BALK.	1	175W HPS BALLAST	100	377	SUN VALLEY LIGHTING CAT. NO. 133-02-2-28-05-1-277-0203-02-NC RECREATING SUN VALLEY LIGHTING FIXTURE AND POLE TO MATCH STA TRANSIT CENTER PHASE 1 PROCESSION BALK. BASE COLOR AMERICAN BOND PLATE SILVER ACCENT COLOR PAVING GOLD	
A1	SURFACE MOUNTED 4-AMP FLOURESCENT FIXTURE WITH COMPASS PROTECTION IN CASE STUDY BODY AND BRUNNER FINISH SUITABLE FOR HOT LOCATIONS. THIRTY TWO WATT AND HOLDER BUSH CHANNEL FOR WIRING THROUGH ACCESS LEAD SHALL BE 0.125" THICK POLYCARBONATE PROVIDE ELECTRONIC BALLAST AND 2-1/2 LAMPS (CLASSIFY LIGHTS)	2	F008 15 48	30	37		L9	SAME AS TYPE "A1" EXCEPT 400W LAVOYER PLATFORM	1	400W HPS TYPE B	400	377	SUN LIGHTING CAT. NO. 30-402-250P210-00 POLE HEIGHT = PER PLAN POLE CAT. NO. R3229-520-A/5A-00	
A2	SURFACE MOUNTED 4-AMP FLOURESCENT FIXTURE WITH 1/4" STAINLESS STEEL IMPACT EXTRUSION CLEAR POLYCARBONATE LENS. HANGING BRACKS ALUMINUM HOUSING AND STAINLESS STEEL. THERMO-RESISTANT INSULATING PARTS PROVIDE ELECTRONIC BALLAST AND 2-1/2 LAMPS (CLASSIFY LIGHTS)	2	F008 15 48	30	100		L10	POLE MOUNTED LAMPBURN WITH ONE-PIECE DIE-CAST LOW COPPER ALUMINUM ALLOY WITH INTERNAL COOLING HOLES OVER THE OPTICAL CHAMBER AND ELECTRICAL COMPARTMENT HOUSING. HOUSING WITH STAINLESS STEEL PINE SPECULAR ALUM. REFLECTION MODULE. SUPER TCC. THERMOSET POLYESTER POWDER FROM ELECTRICAL MIDDLE AND ALL IN RETROFITTED ISOLATED ON A SINGLE PLATE AND FACTORY PRE-WIRED WITH QUICK DISCONNECT PLUGS.	1	250W HPS TYPE B	250	308	SUN LIGHTING CAT. NO. 30-402-250P210-00 POLE HEIGHT = PER PLAN POLE CAT. NO. R3229-520-A/5A-00	
A3	SAME AS TYPE "A2" EXCEPT 1 LAMP	1	F032 75 48	32	100		L8	SAME AS TYPE "A2" EXCEPT 2 LAMP	2	250W HPS TYPE B	250	308	SUN LIGHTING CAT. NO. 30-402-250P210-00 POLE HEIGHT = PER PLAN POLE CAT. NO. R3229-520-A/5A-00	
A11	POLE MOUNTED LAMPBURN WITH ONE-PIECE DIE-CAST LOW COPPER ALUMINUM ALLOY WITH INTERNAL COOLING HOLES OVER THE OPTICAL CHAMBER AND ELECTRICAL COMPARTMENT HOUSING. HOUSING WITH STAINLESS STEEL PINE SPECULAR ALUM. REFLECTION MODULE. SUPER TCC. THERMOSET POLYESTER POWDER FROM ELECTRICAL MIDDLE AND ALL IN RETROFITTED ISOLATED ON A SINGLE PLATE AND FACTORY PRE-WIRED WITH QUICK DISCONNECT PLUGS.	1	250W HPS TYPE B	250	240		L10	SAME AS TYPE "A11" EXCEPT POLE IS 40" HIGH WITH TYPE 2 DISTRIBUTION STATION PLATFORM	1	250W HPS TYPE B	250	308	SUN LIGHTING CAT. NO. 30-402-250P210-00 POLE HEIGHT = PER PLAN POLE CAT. NO. R3229-520-A/5A-00	
L2	SAME AS TYPE "L1" EXCEPT 2 LAMP	2	250W HPS TYPE V	250	240									
L3	SAME AS TYPE "L1" EXCEPT POLE IS 40" HIGH WITH TYPE 2 DISTRIBUTION STATION PLATFORM	1	250W HPS TYPE B	250	240									
L4	SAME AS TYPE "L1" EXCEPT 377 LAVOYER PLATFORM	1	250W HPS TYPE B	250	377									
L3	POLE MOUNTED LAMPBURN WITH ONE-PIECE DIE-CAST ANODIZED CORNER ALUMINUM HOUSING AND TEMPERED PLAT GLASS LENS. CLIP ON TO MATCH EXISTING HOUSING. MOUNTED ALUMINUM REFLECTOR. MOUNTING HEIGHT SHALL BE PER PLAN LAMP TO BE 2500 MM. PREVIOUS SCHEME IS LISTED FOR HOT LOCATIONS. COMPASS PERMS ONE (1)	1	250W HPS TYPE B	240	240									
L6	SAME AS TYPE "L1" EXCEPT 2 LAMP	2	250W HPS TYPE V	400	240									
L7	DIE-CAST FINNER LAMP LOCATED ON LOWER HOUSING UNIT. POLYESTER POWER PART FROM 0-6 ELIMINATE. SPECIES FOR SUPERIOR COMPASSION-RESISTANCE. CONSTRUCTION CONSTANT WALLS. AUTOMATICALLY ELECTRICAL BALLAST. FULL CUT-OFF PLAT LENS DISTRIBUTION. PMA BAILO OPTICAL ASSEMBLY.	1	250W HPS TYPE B	250	400									

MODEL
FIXTURE TYPES SPECIFIED ARE INDICATED TO ESTABLISH A LEVEL OF QUALITY. EQUIVALENT TYPES MUST BE SUBMITTED FOR APPROVAL.

RIVERSIDE COUNTY TRANSPORTATION COMMISSION
 PROJECT: RCTC PERRIS VALLEY LINE
 DRAWING: LIGHTING FIXTURE SCHEDULE
 DATE: 10-24-15
 SHEET NO: 1649 OF 2599

RIVERSIDE COUNTY TRANSPORTATION COMMISSION PROJECT: RCTC PERRIS VALLEY LINE DRAWING: LIGHTING FIXTURE SCHEDULE DATE: 10-24-15				RCTC PERRIS VALLEY LINE PROJECT WIDE LIGHTING FIXTURE SCHEDULE		SHEET NO: 1649 OF 2599 DATE: 10-24-15 SCALE: NONE	
DESIGNED BY: A. VENTURATO CHECKED BY: A. VENTURATO DATE: 10-24-15	PROJECT MANAGER: A. VENTURATO DATE: 10-24-15	CONTRACTOR: STV Incorporated DATE: 10-24-15			APPROVED BY: 		SCALE: NONE



BASE

ONE PIECE CORROSION RESISTANT, DURABLE CAST ALUMINUM CONSTRUCTION. MINIMUM .210 WALL THICKNESS. BASE CONSISTS OF A SMOOTH, TAPERED BOTTOM SECTION, AND A HIGHLY DETAILED, DECORATIVE FLUTED SECTION, A DECORATIVE CAST ALUMINUM COLLAR AND A FLUTED HAND HOLE COVER CONTOURED TO BASE DESIGN. HAND HOLE COVER SUPPLIED WITH TAMPER RESISTANT HARDWARE. GROUNDING LUG PROVIDED INSIDE BASE OPPOSITE HAND HOLE.

ANCHORAGE

A 3/4" CAST ALUMINUM ANCHOR RING IS WELDED 1" ABOVE BOTTOM OF BASE TO ACCEPT (4) FULLY GALVANIZED ANCHOR BOLTS. EACH BOLT SUPPLIED WITH TWO NUTS AND TWO WASHERS. ANCHORAGE IS FASTENED THROUGH HAND HOLE.

FINISH

ELECTROSTATICALLY APPLIED BAKED ON TEXTURED ACRYLIC ENAMEL. (SEE PAGE 5 FOR OPTIONAL FINISH AND COLOR SELECTION)

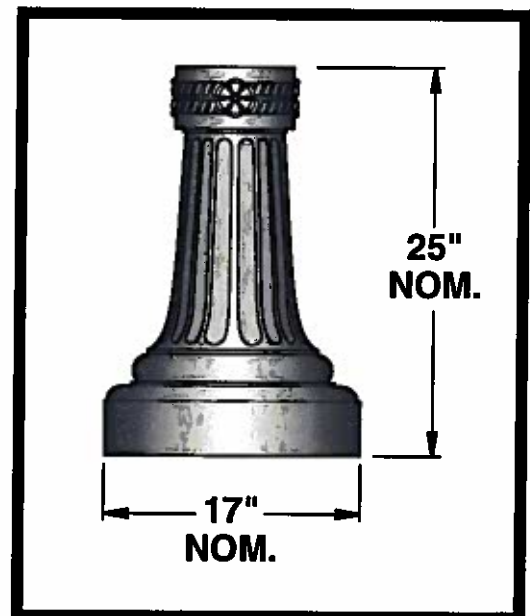

FLUTED

FLUTED

EXHIBIT C-6

ROUND EXTRUDED FROM 6063 ALLOY ALUMINUM. HEAT TREATED TO PRODUCE A T6 TEMPER. SHAFTS HAVE EVENLY SPACED HIGHLY DETAILED RAISED VERTICAL FLUTES.

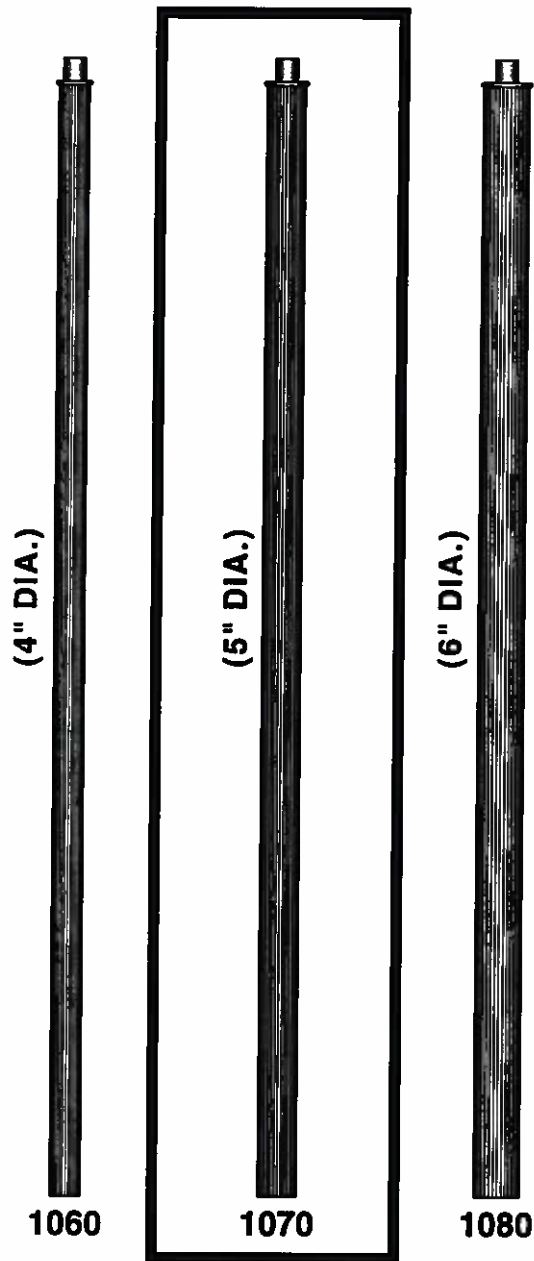

(FLUTED ALUMINUM SHAFTS)
SHAFT WALL THICKNESS .188

POLES PROVIDED WITH TENON TOP
POST TOP (PT): 2 7/8" O.D. X 3"
MULTIPLE LUMINAIRES: 2 7/8" O.D. X 6"



The Lighting Tradition

sun valley
LIGHTING

660 WEST AVENUE O, PALMDALE, CA 93551
(661) 233-2030
FAX (661) 233-2001
www.sunvalleylighting.com

LCR

EXHIBIT C-6

CAST ALUMINUM CONSTRUCTION. LUMINAIRE PROVIDED WITH ACRYLIC OR POLYCARBONATE LENSES

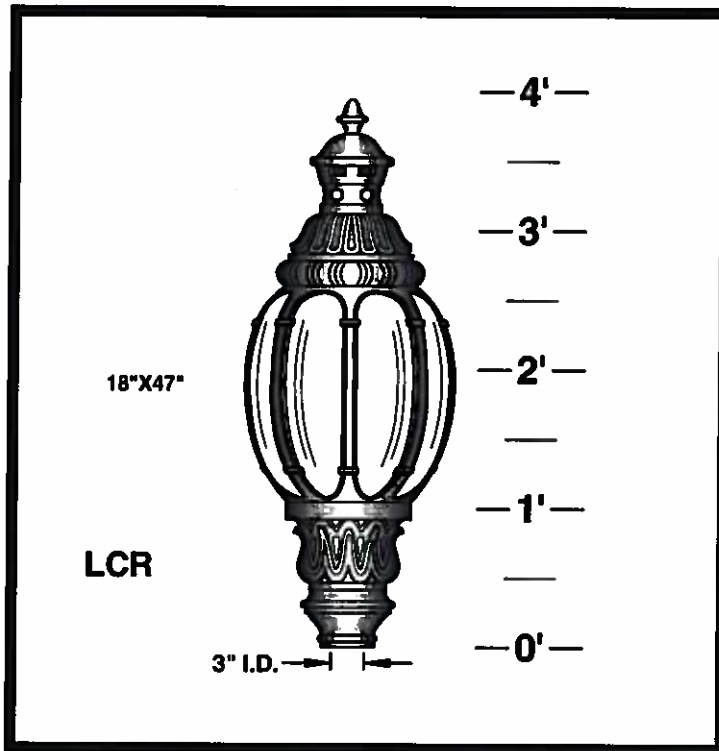

LUMINAIRE ACCESSORIES

(SPECIFY AS SUFFIX TO LUMINAIRE NO.)

INTERNAL LOUVER



IL

WIDE ANGLE LOUVER SYSTEM



OPT

PRISMATIC GLASS REFRACTOR
TYPE III
TYPE V



PG-III
PG-V

GLASS CHIMNEY
CLEAR OR
3/4 FROSTED



GCC
GCF

STANDARD PANELS:
CLEAR PATTERNED ACRYLIC

OPTIONS:
OPAL SMOOTH ACRYLIC.....WA
CLEAR SMOOTH ACRYLIC.....CA
OPAL SMOOTH POLYCARBONATE.....WP
CLEAR SMOOTH POLYCARBONATE.....CP

HOUSE SIDE SHIELD 90°.....HS90°
135°.....HS135°
180°.....HS180°

PHOTO CELL + VOLTAGE
(EXAMPLE: PC120V).....PC+V

SINGLE FUSE (120V., 277V.).....SF

DOUBLE FUSE (208V., 240V., 480V.).....DF

BALLASTS ARE H.P.F. / C.W.A. AUTOTRANSFORMER, -20° STARTING TEMPERATURE

METAL HALIDE	HIGH PRESSURE SODIUM	MERCURY VAPOR	INC.	FOR FLUOR. LAMPS CONSULT FACTORY
50W.	50W.	50W.	TO	
70W.	70W.	75W.	200W.	
100W.	100W.	100W.		
175W.	150W.	175W.		
250W.	250W.	250W.		



sun valley
LIGHTING

660 WEST AVENUE O, PALMDALE, CA 93551
(661) 233-2000
FAX (661) 233-2001
www.sunvalleylighting.com

LC-13

EXHIBIT C-7

D STREET

6TH STREET

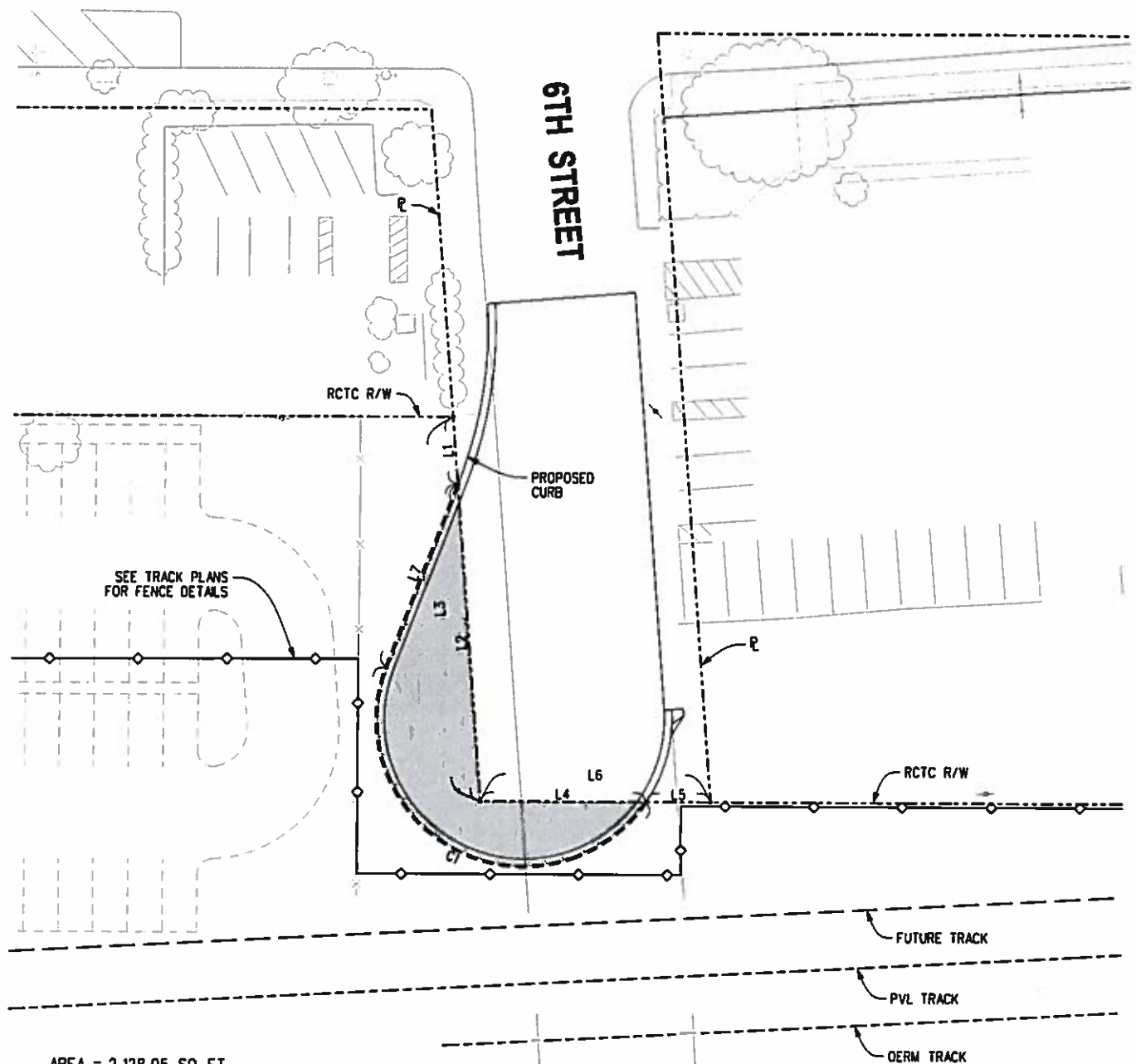

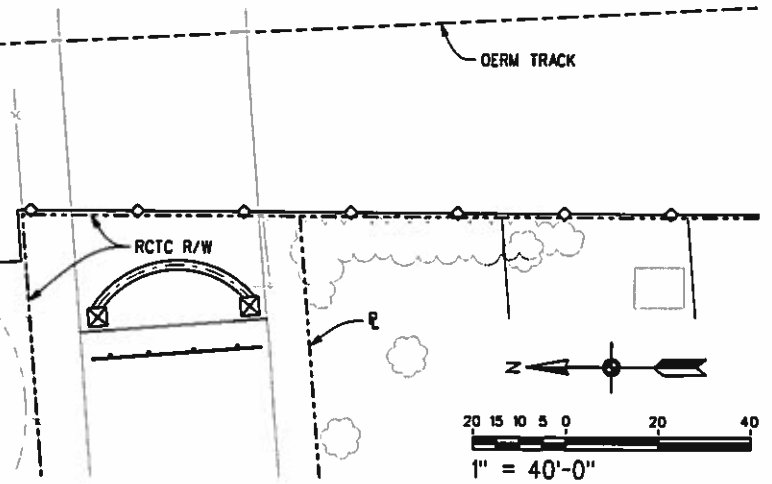

AREA = 2,128.05 SQ FT

DATA TABLE				
DATA NO.	Δ/BEARING	R	L	DESCRIPTION
L1	N89° 38' 30" W	-	17.69'	RCTC R/W
L2	N89° 38' 30" W	-	82.63'	RCTC R/W
L3	N89° 38' 30" W	-	100.32'	RCTC R/W
L4	N04° 57' 28" E	-	43.25'	RCTC R/W
L5	N04° 57' 28" E	-	16.95'	RCTC R/W
L6	N04° 57' 28" E	-	60.20'	RCTC R/W
L7	N64° 06' 42" W	-	50.90'	LICENSE BOUNDARY
C1	166° 15' 42"	38.50'	111.72'	LICENSE BOUNDARY



8/5/2013 3:22:40 PM USER = borrad
 C:\Users\borrad\Documents\Projects\20130802_Perris-Sign-Maintenance-Areas\04_West-6th-Street.dwg
 C:\Users\borrad\Documents\Projects\20130802_Perris-Sign-Maintenance-Areas\04_West-6th-Street.dwg
 C:\Users\borrad\Documents\Projects\20130802_Perris-Sign-Maintenance-Areas\04_West-6th-Street.dwg

RIVERSIDE COUNTY TRANSPORTATION COMMISSION

STV Incorporated
ENGINEERS/ARCHITECTS/PLANNERS/CONSTRUCTION MANAGERS
 9150 ANAHEIM PLACE, SUITE 210
 RANCHO CUCAMONCA, CA 91730-8540

**RCTC PERRIS VALLEY LINE
 DOWNTOWN PERRIS STATION E
 6TH STREET**

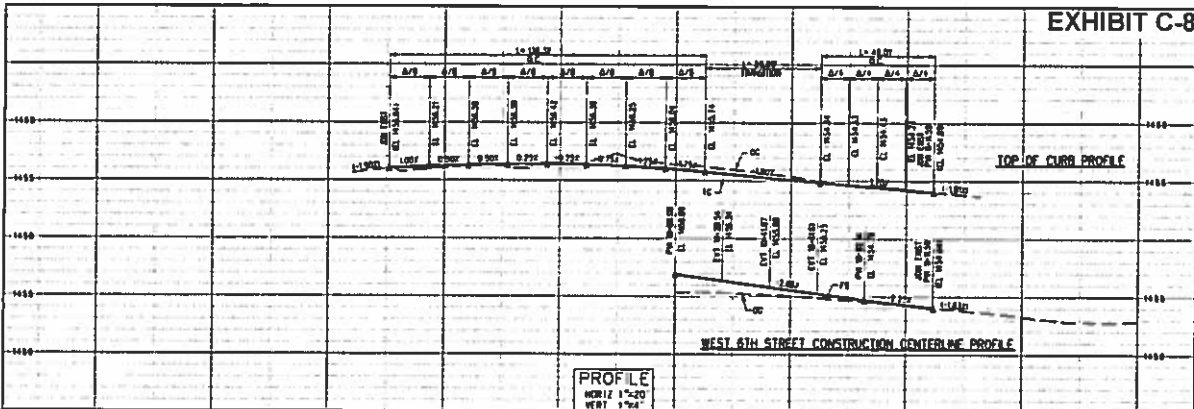
EXHIBIT C-8



PROFILE
HORIZ 1"=20'
VERT 1"=4'

- CONSTRUCTION SYMBOLS**
- CONSTRUCT
 - EXISTING
 - REMOVE
 - RENAME EXISTING
 - REMOVE AND CONSTRUCT
 - WORK BY OTHERS
 - PROTECT IN PLACE

- CONSTRUCTION NOTES:**
- 1 6" CURB & GUTTER
 - 2 6" CURB & GUTTER
 - 3 8" CURB FOR EXISTING PAVEMENT
 - 4 6" CURB
 - 5 1" F&C CONCRETE
 - 6 RESIDENTIAL DRIVEWAY WITH A.C. BIWE
 - 7 RESIDENTIAL DRIVEWAY WITH SIDEWALK AT CURB
 - 8 COMMERCIAL DRIVEWAY WITH SIDEWALK AT CURB
 - 9 CROSS CUTTER
 - 10 CROSS CUTTER WITH SPLASH AREA
 - 11 ASPHALT CONCRETE BIWE
 - 12 RESIDENTIAL DRIVEWAY WITH SIDEWALK AT R/W
 - 13 AC PAVEMENT PER TYPICAL CROSS SECTION
 - 14 COLD MILL EXISTING AC
 - 15 SARCUT
 - 16 CUTTER DEPRESSION FOR CURB OPENING CO
 - 17 ASPHALT PAVEMENT FOR GRADE CROSSING
 - 18 CURB RAMP
 - 19 TREE
 - 20 SAFETY LIGHTING
 - 21 STREET SIGN
 - 22 CURB WALL
 - 23 TRAFFIC SIGNAL PULL BOX
 - 24 RETAINING WALL
 - 25 FINE HYDRANT
 - 26 WATER METER
 - 27 BUMPLE
 - 28 UTILITY POLE
 - 29 UTILITY POLE ANCHOR
 - 30 BARRICADE
 - 31 PEDESTRIAN WARNING DEVICE AND GATE W/ FLASHER
 - 32 WARNING DEVICE ASSEMBLY
 - 33 PEDESTRIAN SOUND GATE
 - 34 PEDESTRIAN WARNING DEVICE AND GATE
 - 35 DETECTABLE WARNING STEP
 - 36 PEDESTRIAN BARRICADE AND METAL HAND RAILING
 - 37 WIRE MESH TYPE FENCE
 - 38 SECURITY ACCESS GATE
 - 39 DOLLARD
 - 40 SIGNAL SHELTER
 - 41 PRECAST CONCRETE PANEL GRADE CROSSING SYSTEM
 - 42 REINFORCED CONCRETE BLOCK WALL
 - 43 RIVER EDGE
 - 44 CLASS 440 PER TYPICAL CROSS SECTION
 - 45 MAINTENANCE ROAD

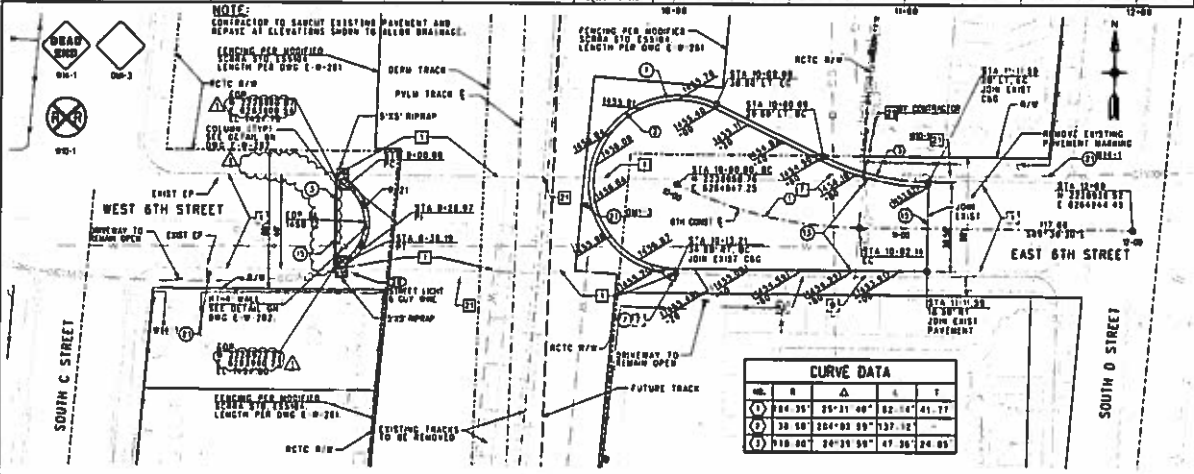

NO.	R	Δ	L	T
1	124.35'	35°31'40"	82.14'	21.77'
2	38.58'	284°03'55"	137.12'	-
3	118.80'	24°15'55"	67.36'	24.85'

- NOTES:**
1. REFER TO PDC S-10-005 FOR LEGEND AND ABBREVIATIONS.
 2. REFER TO SDC S-10-004 FOR CONSTRUCTION NOTES.
 3. REFER TO TRACK PLANS FOR TRACK ALIGNMENT.
 4. REFER TO SYSTEMS PLAN INSTRUMENT S-11-005.
 5. COLD MILL 5" EXISTING AC PAVEMENT ABOVE ALL SARCUT LINES.

<p>CITY OF PERRIS, CALIFORNIA DEPARTMENT OF ENGINEERING</p> <p>DESIGNED BY: [Name] CHECKED BY: [Name] DATE: 10-24-11</p>	<p>RIVERSIDE COUNTY TRANSPORTATION COMMISSION</p> <p>DESIGNED BY: [Name] CHECKED BY: [Name] DATE: 10-24-11</p>	<p>STV Incorporated</p> <p>10-24-11</p>	<p>RCTC PERRIS VALLEY LINE WEST 6TH STREET CROSSING CLOSURE PLAN</p> <p>CPCU NO. 002X-19.03, MP 19.03, USDOT NO. 027342D</p>
---	---	--	---

EXHIBIT "D"

INSURANCE REQUIREMENTS

Licensee shall obtain, and shall require any consultant or contractor entering the Licensed Property on its behalf to obtain insurance of the types and in the amounts described below and satisfactory to the RCTC.

A. Commercial General Liability Insurance. Licensee shall maintain occurrence version commercial general liability insurance or equivalent form with a combined single limit of not less than \$2,000,000 per occurrence. If such insurance contains a general aggregate limit, it shall apply separately to this Agreement or be no less than two times the occurrence limit. Such insurance shall include coverage for, but not be limited to: (i) bodily injury and property damage; (ii) personal injury and advertising injury; (iii) fire legal liability; and (iv) products and completed operations. Such insurance policy or policy endorsement shall:

1. Include the RCTC, its officials, officers, employees, agents, and consultants as additional insureds with respect to the Licensed Property and Licensee's installation, construction, operation, maintenance, repair, reconstruction, alteration, removal or any other work that Licensee undertakes with respect to the Facility and any Future Improvements;
2. Not contain special limitations on the scope of coverage or the protection afforded to RCTC, its officials, officers, employees, agents and consultants as additional insureds;
3. Be primary with respect to any insurance or self-insurance programs covering RCTC, its officials, officers, employees, agents and consultants; and
4. Contain standard separation of insured provisions.
5. Contain a waiver of subrogation that waives any right the insurer has against RCTC for any claims or suits.
6. Not include any restrictions related to indemnity for work performed within fifty (50) feet of RCTC's railroad right-of-way/tracks.

B. Railroad Protective Liability. Licensee shall, in connection with the Licensed Property and Licensee's installation, construction, operation, maintenance, repair,

Exhibit "D"

reconstruction, alteration, removal or any other work that Licensee undertakes with respect to the Facility or any Future Improvements, acquire and keep in force during the period of such activities \$2,000,000 (combined single limit)/ \$6,000,000 (aggregate limit) of railroad protective liability insurance naming only RCTC as the insured.

C. Automobile Liability. Licensee shall acquire and maintain during the period of the Project, automobile liability with a combined single limit of one million dollars (\$1,000,000).

D. Pollution Liability Insurance. If the Project will result in exposure of hazardous materials to the Licensed Property, either directly by Licensee or by its contractors, or if the Facility is used to carry Hazardous Materials, Licensee shall acquire and maintain during the period of the Project pollution liability insurance with a combined single limit of one million dollars (\$1,000,000) and a general aggregate limit of two million dollars (\$2,000,000). Such insurance shall comply with all applicable provisions of this Exhibit "D".

E. Workers' Compensation Insurance. Licensee shall maintain workers' compensation insurance with statutory limits and employers' liability insurance with limits of not less than \$1,000,000 each accident.

F. Certificates of Insurance. Licensee shall, prior to (i) entering the Licensed Property or (ii) performing any installation, construction, operation, maintenance, repair, reconstruction, alteration, removal or any other work that Licensee undertakes with respect to the Facility or any Future Improvements, furnish RCTC with properly executed certificates of insurance and, if requested by RCTC, certified copies of endorsements and policies, which clearly evidence all insurance required under this Agreement and provide that such insurance shall not be canceled, allowed to expire or be materially reduced in coverage, except on thirty (30) days' prior written notice to RCTC. RCTC shall have the sole discretion to determine whether the certificates and endorsements presented comply with the provisions of this Agreement.

G. Coverage Maintenance. Licensee shall replace certificates, policies and endorsements for any insurance expiring prior to the termination of this Agreement and shall not allow any lapse in coverage. Further, Licensee shall maintain such insurance from the execution of this Agreement until the Facility and any Future Improvements are removed and the Licensed Property fully restored, except as otherwise provided in this Agreement.

H. Licensed Insurer. Licensee shall place such insurance with insurers having A.M. Best Company ratings of no less than A:VIII and licensed to do business in California.

Exhibit "D"

Exhibit "D"

17336.00603\8207651.7