



CITY OF PERRIS PLANNING COMMISSION

AGENDA

September 2, 2020

City Council Chambers
Meeting to convene at 6:00 P.M.
101 North "D" Street
Perris, CA 92570

1. CALL TO ORDER:

2. ROLL CALL:

Commissioners: Hernandez, Jimenez,
Vice-Chair Hammond, Chair Shively

3. INVOCATION:

4. PLEDGE OF ALLEGIANCE: Commissioner Hernandez

5. PRESENTATION:

6. CONSENT CALENDAR:

A. Planning Commission Minutes for July 1, 2020

7. PUBLIC HEARING:

A. **General Plan Amendment (GPA) 16-05217, Zone Change (ZC) 16-05218, and TTM 36647 (16-05216)** – A proposal to amend the General Plan and Zoning designation of approximately 24.1 acres located at the northwest of Ramona Expressway and Evans Road from Specific Plan (GP designation) and R-10,000 (Zoning designation) to R-6,000 to facilitate a 90 single-family lot subdivision with two (2) lettered lots (A and B), and a 30.7-acre borrow site. **Applicant:** Jason Keller, Mission Pacific Land Company

REQUESTED ACTION: Adopt Resolution No. 20-09 recommending that the City Council **Adopt** the Mitigated Negative Declaration (2339), and **Approve** General Plan Amendment (GPA) 16-05217, Zone Change (ZC) 16-05218, and Tentative Tract Map 36647 (TTM16-05216), and based on the findings contained in the Resolution and attached exhibits.

8. BUSINESS ITEM:

- A. Nomination and Appointment of Planning Commission Chair and Vice-Chair
- B. Nomination and Appointment of Two Planning Commissioners for the AD HOC Committee

9. PUBLIC COMMENTS:

Anyone who wishes to address the Planning Commission regarding items not on the agenda may do so at this time. Please walk up to the podium and wait for the Chairperson to recognize you. Please speak clearly, give your name, spell your last name, and address for accurate recording in the minutes. Each speaker will be given three (3) minutes to address the Planning Commission.

10. COMMISSION MEMBERS ANNOUNCEMENTS OR REPORTS:

11. DIRECTOR OF DEVELOPMENT SERVICES REPORTS AND/OR INFORMATION:

12. ADJOURNMENT

Planning Commission Agenda

CITY OF PERRIS
September 2, 2020

Item 6A

Planning Commission Minutes for July 1, 2020

CITY OF PERRIS

MINUTES:

Date of Meeting: July 1, 2020

05:59 PM

Place of Meeting: City Council Chambers

Commission Members Present: Commissioner Jimenez, Commissioner Hernandez, Vice Chair Hammond, and Chair Shively.

1. CALL TO ORDER:

2. ROLL CALL: Commissioners: Hernandez, Jimenez, Vice-Chair Hammond, Chair Shively

Commission Members Present: Commissioner Jimenez, Commissioner Hernandez, Vice Chair Hammond, and Chair Shively.

3. INVOCATION:

4. PLEDGE OF ALLEGIANCE: Commissioner Jimenez

5. PRESENTATION:

6. CONSENT CALENDAR:

A. Planning Commission Minutes for May 20, 2020

The Chair called for a motion.

M/S/C: Moved by Vice Chair Hammond, seconded by Commissioner Jimenez to Approve Planning Commission Minutes for May 20, 2020

AYES: Commissioner Jimenez, Commissioner Hernandez, Vice Chair Hammond, Chair Shively.

NOES:

ABSENT:

ABSTAIN:

7. PUBLIC HEARING:

- A. Tentative Parcel Map 19-05303 (PM 37760) and Conditional Use Permit 19-05301 – A proposal to subdivide an existing 13-acre commercial parcel within the Spectrum Shopping Center (aka Old Walmart Site) to facilitate the development of a 5,200 SF multi-tenant building and a 2,200 SF fast food restaurant along the west frontage of Perris Boulevard north of Orange Avenue. Applicant: Iku Shimomura, ADN Architects, Inc. REQUESTED ACTION: ADOPT Resolution No. 20-10 finding the

project Categorically Exempt from CEQA under Section 15332, Class 32 In-fill development, and approving Tentative Parcel Map 19-05303 (PM 37760) and Conditional Use Permit 19-05301 to facilitate the development of a multi-tenant building and fast food restaurant, located along the west frontage of Perris Boulevard north of Orange Avenue based on the findings contained in the staff report and subject to the Conditions of Approval.

Commissioners Shively, Hammond, and Jimenez acknowledged that they visited the site prior to the meeting.

Associate Planner Garcia, presented the item to the Commission.

Commissioner Jimenez, requested clarification on the creation of the proposed parcels.

Vice Chair Hammond, requested clarification on the layout of the multi-tenant and drive-thru buildings, and asked about the covered pedestrian walkway.

Chair Shively, commented on the parking requirement for parcel #2 and future LMD landscaping requirements.

Commissioner Jimenez, asked about the color scheme and compared it to the Plaza de Perris.

Chair Shively, noted that the proposed architecture does not match the existing buildings within the center.

Applicant John Dodson, presented to the Commission.

Commissioner Jimenez, asked about an alternative color palette, and commented that darker earth tone colors can fade quickly.

Commissioner Hernandez, asked why Fitness 19 was chosen as an example for the color scheme.

Vice Chair Hammond, commented on the color scheme of the neighboring Taco Bell and how it is more contemporary.

Chair Shively, asked about site access from N Perris Blvd.

Applicant John Dodson, addressed the Commission.

Commissioner Jimenez, noted that she understood the color scheme proposed but would like to alter it so it may be the model for future development in the area.

Vice Chair Hammond, spoke on the veneer treatments provided and appreciated the walk-ability of the buildings.

Chair Shively, approved of the project design and noted his only issue with the project was the colors as this project will set precedence for future renovations and development within the shopping center.

Assistant City Attorney Khuu, clarified the motion.

The Chair called for a motion.

M/S/C: Moved by Vice Chair Hammond, seconded by Commissioner Jimenez to Approve A. Tentative Parcel Map 19-05303 (PM 37760) and Conditional Use Permit 19-05301 – A proposal to subdivide an existing 13-acre commercial parcel within the Spectrum Shopping Center (aka Old Walmart Site) to facilitate the development of a 5,200 SF multi-tenant building and a 2,200 SF fast food restaurant along the west frontage of Perris Boulevard north of Orange Avenue. Applicant: Iku Shimomura, ADN Architects, Inc.

REQUESTED ACTION: ADOPT Resolution No. 20-10 finding the project Categorically Exempt from CEQA under Section 15332, Class 32 In-fill development, and approving Tentative Parcel Map 19-05303 (PM 37760) and Conditional Use Permit 19-05301 to facilitate the development of a multi-tenant building and fast food restaurant, located along the west frontage of Perris Boulevard north of Orange Avenue based on the findings contained in the staff report and subject to the Conditions of Approval. Addition of condition of approval for reciprocal access and updating of the parking space count.

AYES: Commissioner Jimenez, Commissioner Hernandez, Vice Chair Hammond, Chair Shively.

NOES:

ABSENT:

ABSTAIN:

8. BUSINESS ITEM:

9. PUBLIC COMMENTS: Anyone who wishes to address the Planning Commission regarding items not on the agenda may do so at this time. Please walk up to the podium and wait for the Chairperson to recognize you. Please speak clearly, give your name, spell your last name, and address for accurate recording in the minutes. Each speaker will be given three (3) minutes to address the Planning Commission.

10. COMMISSION MEMBERS ANNOUNCEMENTS OR REPORTS:

Commissioner Jimenez, commented on COVID safety requirements for her daily routines.

Vice Chair Hammond, requested to schedule a discussion on MFR housing and noted that it should be a priority for the City.

Chair Shively, commented on a tour to MFR sites if possible, and if not a presentation or virtual tour.

11. DIRECTOR OF DEVELOPMENT SERVICES REPORTS AND/OR INFORMATION:

Planning Manager Phung, commented on scheduling a date for the tour, multi-family project in the Green Valley, status of updating of the housing element, Steve Perrez resignation from the Commission, Chair and Vice Chair nominations for next meeting, executive order closing indoor dining and the City's response, and the next meeting on July 15th.

Vice Chair Hammond, voiced his support for the tour and that seeing development in person is helpful.

12. ADJOURNMENT 1 Page 2 of 2

Planning Commission Agenda

CITY OF PERRIS
September 2, 2020

Item 7A

General Plan Amendment (GPA) 16-05217, Zone Change (ZC) 16-05218, and Tentative Tract Map 36647 (TTM16-05216)



CITY OF PERRIS

PLANNING COMMISSION

AGENDA SUBMITTAL

MEETING DATE: September 2, 2020

SUBJECT: **General Plan Amendment (GPA) 16-05217, Zone Change (ZC) 16-05218, Tentative Tract Map 36647 (TTM16-05216)** – A proposal to amend the General Plan Land Use and Zoning designation of approximately 24.1 acres located at the northwest corner of Ramona Expressway and Evans Road from Specific Plan (GP designation) and R-10,000 (zoning designation) to R-6,000 to facilitate a 90 single-family lot subdivision with two (2) lettered lots (A and B), and a 30.7-acre lot burrow site. **Applicant:** Jason Keller, Mission Pacific Land Company.

REQUESTED ACTION: **Adopt Resolution No. 20-09** recommending that the City Council **Adopt** the Mitigated Negative Declaration (2339), and **Approve** General Plan Amendment (GPA) 16-05217, Zone Change (ZC) 16-05218, and Tentative Tract Map 36647 (TTM16-05216), and based on the findings contained in the Resolution and attached exhibits.

CONTACT: Kenneth Phung, Planning Manager

BACKGROUND/DISCUSSION:

The applicant, *Mission Pacific Land Company*, is proposing to amend the General Plan Land Use and Zoning designation of approximately 24.1 acres located at the northwest corner of Ramona Expressway and Evans Road from Specific Plan (General Plan designation) and R-10,000 (Zoning designation) to R-6,000 to facilitate a 90 single-family lot subdivision with two (2) lettered lots (A and B), and 30.7-acre lot for a borrow site. The purpose of the borrow site is to obtain fill and raise the tract out of the flood zone that will ultimately be developed for a regional detention basin to be constructed at a future date. Overall, the subdivision and borrow site encompasses approximately 54-gross acres. The proposal will also be an extension of the Stratford Ranch residential subdivision to the north consisting of 270 single-family lots approved by the City Council on August 29, 2017. That proposal also involves a General Plan Amendment to Zone Change from Specific Plan to R-6,000, as both properties were part of a Specific Plan adopted in 2005 that encompasses an area bounded by Redlands Avenue to the west, South Lake Perris Drive to the east, Ramona Expressway to the south and the Moreno Valley City limits to the north.

The subdivision has lots ranging from a minimum of 6,000 square feet to 15,653 square feet with a lot average of 7,284 square feet. The proposed density is four (4) dwelling units per acre, which is below the max density of the R-6,000 zone, which allows up to 7 dwelling units per acre. The subdivision also includes lettered lot "A" for storm drain easement between lots 11 and 12 along the southern end of the tract, and an adjacent lettered lot "B" (72,117 sq. ft.) for a detention basin to adequately convey drainage flows. Also, the developer will construct a 10' wide Class I bike lane, with a 4.5-foot-wide decomposed granite trail within the service road along the east bank of the Perris Valley Storm Channel (PVSC) consistent with the Perris Trail Master Plan.

In accordance with the California Environmental Quality Act (CEQA), a Notice of Intent (NOI) to adopt a Mitigated Negative Declaration was filed for a thirty (30) day review. The public review period commenced on May 13, 2020 and ended on June 15, 2020. As of writing this report, no comment letters were received from any adjacent property owner or state agencies.

BUDGET (or FISCAL) IMPACT: Cost for staff preparation of this item, cost of construction, and payment of impact fees are covered by the applicant.

Prepared by: Nathan Perez, Senior Planner

REVIEWED BY: Kenneth Phung, Planning Manager

Attachments: Staff Report
Exhibit A – Conditions of Approval (Planning, Engineering, Public Works, Building, and Community Services)
Exhibit B – Aerial View
Exhibit C – Vicinity Map
Exhibit D – Zone Change Exhibit
Exhibit E – General Plan Amendment exhibit
Exhibit F – Evans Road Memo and exhibit
Exhibit G – Perris Valley Storm Channel Trail Cross section
Exhibit H – PC Resolution 20-09
Exhibit I – MND/Initial Study
Exhibit J – MMRP
Exhibit K – TTM 36647 exhibit

Consent:
Public Hearing: X
Workshop:
Presentation:
Other:

**CITY OF PERRIS
DEVELOPMENT SERVICES DEPARTMENT
PLANNING DIVISION**

PROJECT REPORT

CASE NUMBER: General Plan Amendment (GPA) 16-05217
Zone Change (ZC) 16-05218
TTM 36647 (16-05216)

Environmental Determination: An Initial Study has been prepared for the proposed Project, which determined that, subject to mitigation measures, there is no substantial evidence of adverse environmental effects therefore a Mitigated Negative Declaration (2339) has been prepared.

Date: September 2, 2020

Project Planner: Nathan Perez, Senior Planner

Applicant: Jason Keller
Mission Pacific Land Company
4100 Newport Place, Suite 480
Newport Beach, CA 92660

Owner: John Abel
Stratford Ranch Investors LLC.
4100 Newport Place, Suite 480
Newport Beach, CA 92660

Location: Generally located west along Evans Road, east of the Perris Valley Storm Channel, approximately 1,400 north of Ramona Expressway.

PROJECT DESCRIPTION: A proposal to amend the General Plan Land Use and Zoning designation of approximately 24.1 acres located at the northwest of Ramona Expressway and Evans Road from Specific Plan (GP designation) and R-10,000 (Zoning designation) to R-6,000 to facilitate a 90 single-family lot subdivision with two (2) lettered lots (A and B), and a 30.7-acre borrow site.

Acreage: Tentative Tract Map
APNs: 302-150-009 thru 019 (24.12 acres)

East Drainage Basin
APNs: 302-140-007 & 008 (30.25 acres) & portions of 302-

150-009, and 013-17

Related Cases: General Plan Amendment (GPA) 15-05004
Zone Change (ZC) 15-05003
TTM 36648 (15-05002)

ZONING AND LAND USE:

Existing Zoning: R-10,000 (2 to 4 dwelling units per acre)

Surrounding Zoning: North: R-6,000 (4 to 7 dwelling units per acre)

South: Public (P)

East: R-6,000 (4 to 7 dwelling units per acre)
R-10,000 (2 to 4 dwelling units per acre)

West: Public (P) Perris Valley Storm Channel

Existing Land Use: Vacant Land

Surrounding Land Uses: North: Vacant Land

South: Vacant Land

East: Existing Single-Family neighborhood/Vacant Land

West: Perris Valley Storm Channel

PROJECT ANALYSIS

PROJECT DESCRIPTION/ BACKGROUND

The applicant, *Mission Pacific Land Company*, is proposing to amend the General Plan Land Use and Zoning designation of approximately 24.1 acres located at the northwest corner of Ramona Expressway and Evans Road from Specific Plan (General Plan designation) and R-10,000 (Zoning designation) to R-6,000 to facilitate a 90 single-family lot subdivision with two (2) lettered lots (A and B), and 30.7-acre lot for a borrow site. The purpose of the borrow site is to obtain fill and raise the tract out of the flood zone that will ultimately be developed for a regional detention basin to be constructed at a future date. Overall, the subdivision and borrow site encompasses approximately 54-gross acres. The proposal will also be an extension of the Stratford Ranch residential subdivision to the north consisting of 270 single-family lots approved by the City Council on August 29, 2017. That proposal also involves a General Plan Amendment to Zone Change from Specific Plan to R-6,000, as both properties were part of a Specific Plan adopted in 2005 that encompasses an area bounded by Redlands Avenue to the west, South Lake Perris Drive to the east, Ramona Expressway to the south and the Moreno Valley City limits to the north.

The subdivision has lots ranging from a minimum of 6,000 square feet to 15,653 square feet with a lot average of 7,284 square feet. The proposed density is four (4) dwelling units per acre, which is below the max density of the R-6,000 zone, which allows up to 7 dwelling units per acre. The subdivision also includes lettered lot "A" for storm drain easement between lots 11 and 12 along the southern end of the tract, and an adjacent lettered lot "B" (72,117 sq. ft.) for a detention basin to adequately convey drainage flows. Also, the developer will construct a 10' wide Class I bike lane, with a 4.5-foot-wide decomposed granite trail within the service road along the east bank of the Perris Valley Storm Channel (PVSC) consistent with the Perris Trail Master Plan.

Currently, the site is vacant and accessible through an improved Evans Road (to the east) and surrounded by existing residential neighborhoods to the east, the Perris Valley Storm Channel to the west, vacant land to the north, and south. The topography and elevation ranges from 1457 feet to 1446 feet above sea level (a.s.l.) and gradually slopes downward from north to south.

PROJECT ANALYSIS AND REVIEW

GENERAL PLAN CONSISTENCY

The proposed Project is located within Planning Area 1 of the City of Perris General Plan (2030) Land Use Element. Planning Area 1 is generally located on the northeastern edge of the City, bounded by the City limits to the north and east, and the Ramona Expressway to the south.

The proposal involves amending the General Plan Land Use, and Zoning designation of approximately 24.1 acres located at the northwest of Ramona Expressway and Evans Road from Specific Plan (General Plan designation) and R-10,000 (Zoning designation) to R-6,000 to facilitate a 90 single-family lot subdivision with two (2) lettered lots (A and B), and a 30.7-acre borrow site to raise the tract out of the flood zone. The proposed subdivision would produce a residential density of 4 dwelling units per acre, which is consistent with the density of the adjacent Stratford Ranch Residential project to the north, and the developed *Richmond American Steeplechase* neighborhood (TM 32707) to the east across Evans Road with both projects also obtaining a General Plan Amendment from Specific Plan to R-6,000. As such, the proposed Project would be compatible, and a continuation of the adjacent residential zoning designation, residential density, and land uses immediately to the north and east of the project site. Therefore, the Project is consistent with Goal IV of the City of Perris General Plan (2030) Land Use Element, which states, "to provide consistency among all planning documents."

In addition, the borrow site to raise the project site outside the flood zone is also consistent with the General Plan as it designated for a regional basin that is planned for in the Perris Valley Storm Drain Master Plan. Although, the borrow site will not serve as a basin in the interim, excavating the site will help expedite the construction of the regional basin when it is needed. Specifically, the proposed borrow site is consistent with the intent of Planning Area 1 in the General Plan Land Use Element, which seeks to extend and improve existing infrastructure.

DEVELOPMENT STANDARDS

The proposed General Plan Amendment and rezoning to R-6,000 would enable the applicant to develop 90 single-family lots. The proposed tract map adheres to the R-6,000 development standards, as shown in the table on the following page:

| <i>Development Standard</i> | <i>R-6,000</i> | <i>Complies?</i> |
|-----------------------------|--------------------------------|-------------------------|
| Minimum Lot Size | 6,000 sq. ft. | Yes |
| Minimum Lot Width | 60 feet (65 feet corner lots) | Yes |
| Minimum Lot Depth | 100 feet | Yes |
| Lot Frontage | 60' feet (45' feet cul-de-sac) | Yes |
| Density (Units/Acre) | up to 7 units/Acre | Yes (4 DU/acres) |

All the proposed lots exceed the minimum development standards for the R-6,000 zone, as shown in the chart above. Also, the developer is required to submit an ADPR (Administrative Development Plan Review) for review and approval of architecture, plotting, conceptual landscaping, and fencing when development is ready to start. In addition, the Project is conditioned to submit a minimum of four (4) architectural types, eight (8) color schemes, four (4) floor plans, and a minimum of two (2) materials. This ensures that a variety of architecture and floor plans are provided. Overall, the application will ensure that all development complies with the R-6,000 zoning standards for setbacks and lot coverage.

ONSITE CIRCULATION AND SITE DESIGN

The proposed Project is designed to provide connectivity to the adjacent Stratford Ranch Residential North subdivision (TTM 36648) through Streets "F and "H." The Project will provide two (2) points of access along Evans Road. The northerly right-in and right-out point of access (Street "C") align with Marbella Gate across Evans Road. The two points of access would connect to a series of cul-de-sacs and through streets, creating a looped circulation system that offers a private setting for future residents, while providing safe and efficient access to public trails, sidewalks, and roadways. All internal streets are designated as "local streets," which would require a 60-foot right-of-way (30 feet from centerline) and provide full-width street improvements in accordance with City of Perris standards.

The project site design includes 6,000 square foot lots that are planned in the eastern portion of the subdivision along with the extension of Evans Road, and a mix of lot sizes are proposed in the middle portions of the subdivision to provide variety. Larger lot sizes are proposed along the southern and western boundaries to take advantage of the open areas created by drainage and trail facilities and a mix of sizes are proposed along the northern boundary, near the adjoining subdivision to provide a compatible buffer and transition between the subdivisions.

DRAINAGE

Currently, the project site is within the AE Zone (1% probability of annual flooding) per FEMA (Federal Emergency Management Agency) designation, which is considered to be at a high risk of annual flooding under the National Flood Insurance Program (NFIP). The development of the project site would result in an increase in the amount of impervious surfaces in the form of new single-family homes, roadways, and sidewalks. Conditions resulting from this change in imperviousness will increase rain runoff and reduce infiltration. To address flooding and drainage concerns, the project will mitigate these impacts through a borrow site, widening of the Perris Valley Storm Drain Channel, and an onsite detention basin.

Borrow Site

As discussed earlier, to remove the site from the flood zone the Project will utilize a 30.7 acre borrow site to raise the tract outside of the flood zone. The borrow site is designated for a regional detention basin in the General Plan but will not ultimately be developed for a regional basin until a future date. In the interim, the borrow site will be maintained by the developer, and will be screened by a combination of wrought iron fencing and landscaping.

Perris Valley Storm Channel

The Perris Valley Storm Channel will also be widened by 300' feet from the centerline to convey flows safely through the development and adjacent properties consistent with the Riverside County Flood Control (RCFC) guidelines and the North Perris Valley Master Drainage Plan. The widening will assist in reducing the footprint and the base flood elevations for the project.

Onsite Detention

The proposed Tentative Tract Map will also include a detention basin, which is labeled as lot "B" (72,117 sq. ft.) to reduce and mitigate impervious runoff created by development of the site. This basin will be maintained by the Landscape Maintenance District (LMD) and will convey overflows into the Perris Valley Storm Channel, immediately west of the site. All drainage and flood control facilities and improvements will comply with the *Riverside County Flood Control* requirements and standards.

WALLS, FENCING, ENTRY MONUMENTS

The project perimeter walls along Evans Road, the Perris Valley Storm Channel, and the south property lines shall consist of a 6' high decorative split-face block wall with pilaster columns every 100 feet. The two (2) main entryways (Street "A" and "C") along Evans Road are conditioned to provide entry monumentation to identify the tract. Throughout the interior of the tract, all reverse frontage lots and corner lots with a side street shall include a 6-foot high split face block wall with pilasters. A 5' (five) foot setback behind the property line adjacent to the block wall shall be required to consist of decorative hardscape to include: cemented river rock, and decomposed granite (2 colors) with boulders subject to the review and approval of the Planning Division.

Six-foot high, UV protected vinyl fence is required on the side, and rear property lines interior to the Project (not visible from the public right-of-way) and all enclosed detention basins or storm drain facilities must have decorative wrought iron fencing with decorative pilasters every 60' feet or perimeter wall corner, or lot line corner. If the detention basin abuts a residential property, a 6' foot decorative block wall is required.

PERRIS VALLEY STORM CHANNEL MULTI-USE TRAIL

Per the Perris Trail Master Plan, the developer is required to construct a 10-foot wide Class I bike path, with a 4.5-foot-wide decomposed granite trail within the service road along the east bank of the Perris Valley Storm Channel (PVSC). The trail will extend the entire length of the western boundary of the Project, from the Stratford Ranch Residential North (TM 36648) subdivision, and

continue east towards Evans Road, and along Evans Road to Ramona Expressway. Removable bollards will be provided at each right-of-way access point to prevent access of motorized vehicles.

MARB AIRPORT LANDUSE CONSISTENCY

The proposed Project is located within the March Air Reserve Base/Inland Port Airport Influence Area (March AIA) Zone D (Flight Corridor Buffer) and Zone E (other Airport Environs). Zone D and Zone E have no residential development restrictions subject to a deed notice and disclosure of an aviation easement and notice of "airport in the vicinity" to future property owners.

California Public Utilities Code (CPUC Section 21676) requires that all jurisdictions (County or City) refer all General Plan Amendments, Specific Plan Amendments, Zoning Ordinance, and adoption of building regulations within an Airport Land Use Compatibility Plan (ALUCP) for ALUC review. Additionally, Section 21676.5 of the California Public Utility Code (CPUC) allows the ALUC to review all projects within the Airport Influence Area (AIA) when the local jurisdiction's General Plan is not consistent with the applicable ALUCP. Because the proposed Project involves a General Plan Amendment, it was required to be considered by ALUC to determine its consistency with the March Air Reserve Base/Inland Port Airport Land Use Compatibility Plan (MARB ALUCP).

On October 11, 2018, the Riverside County Airport Land Use Commission (ALUC) considered and determined that the Project is "Conditionally Consistent" with the 2014 March Air Reserve Base/Inland Port Airport Land Use Compatibility Plan (MARB ALUCP).

PUBLIC/AGENCY COMMENTS

A public notice was sent to property owners within 300-feet of the project site and agencies. As of the writing of this report, no comments have been received by staff.

ENVIRONMENTAL DETERMINATION

An Initial Study was prepared for the Project in accordance with the City's guidelines implementing the California Environmental Quality Act. This Initial Study was undertaken for the purpose of deciding whether the Project may have a significant effect on the environment. Of all potential effects evaluated, impacts in the area of biology, cultural, hydrology, noise, and transportation and traffic were identified, but will be reduced to less than significant levels with implementation of mitigation measures identified in the Initial Study. The City did not identify any significant, unavoidable impacts. On the basis of such an Initial Study, staff has concluded that all potential significant effects on the environment can be reduced to a less than significant level through mitigation measures, the design of the development, the zoning code and standard requirements of the City, therefore a Mitigated Negative Declaration (2339) has been prepared.

In accordance with the California Environmental Quality Act (CEQA), a Notice of Intent (NOI) to adopt a Mitigated Negative Declaration was filed for a thirty (30) day review. The public review period commenced on May 13, 2020 and ended on June 15, 2020. As of writing this report, no comment letters were received from any adjacent property owner or state agencies.

RECOMMENDATION

ADOPT Resolution No. 20-09 recommending that the City Council **Adopt** the Mitigated Negative Declaration (2339), and **Approve** Tentative Tract Map 36647 (TTM16-05216), General Plan Amendment (GPA) 16-05217, and Zone Change (ZC) 16-05218 based on the findings contained in the Resolution and attached exhibits.

Attachments: Exhibit A – Conditions of Approval (Planning, Engineering, Public Works, Building and Community Services)
Exhibit B – Aerial View
Exhibit C – Vicinity Map
Exhibit D – Zone Change Exhibit
Exhibit E – General Plan Amendment exhibit
Exhibit F – Evans Road Memo and exhibit
Exhibit G – Perris Valley Storm Channel Trail Cross section
Exhibit H – PC Resolution 20-09
Exhibit I – MND/Initial Study
Exhibit J – MMRP
Exhibit K – TTM 36647 exhibit

EXHIBIT A

Conditions of Approval (Planning, Engineering,
Public Works, Building and Community
Services)

**CITY OF PERRIS
DEVELOPMENT SERVICES DEPARTMENT
PLANNING DIVISION**

CONDITIONS OF APPROVAL

**Tentative Tract Map 36647 (16-05216)
Zone Change 16-05218
General Plan Amendment 16-05217**

Sept 2, 2020

PROJECT: General Plan Amendment (GPA) 16-05217, Zone Change (ZC) 16-05218, Tentative Tract Map 36647 (TTM16-05216) – A proposal to amend the General Plan Land Use and Zoning designation of approximately 24.1 acres located at the northwest corner of Ramona Expressway and Evans Road from Specific Plan (GP designation) and R-10,000 (zoning designation) to R-6,000 to facilitate a 90 single-family lot subdivision with two (2) lettered lots (A and B), and a 30.7-acre lot burrow site. **Applicant:** Jason Keller, Mission Pacific Land Company.

***MITIGATION, MONITORING AND REPORTING PROGRAM (MMRP)**

The Mitigation Monitoring and Reporting Program (MMRP) Checklist is attached to reduce potential traffic, geology, air quality, biological and cultural resource impacts, and shall be implemented in accordance with the timeline, reporting and monitoring intervals listed in the MMRP. The applicant is required to meet all the mitigation measures as conditions of approval.

General Requirements:

1. **Environmental Impact Report Mitigation Monitoring Program.** The project shall at all times comply with all provisions of the adopted Mitigation Monitoring and Reporting Program (MMRP) of the Mitigated Negative Declaration.
2. **Development Standards.** The project shall conform to all requirements of the City of Perris Municipal Code Title 19.
3. **Conformance to Approved Plans.** Development of the project site, building elevations, and conceptual landscaping shall conform substantially to the approved set of plans presented at the **September 2, 2020** Planning Commission hearing, or as amended by these conditions and as approved by the City Council. Any deviation shall require appropriate Planning Division review and approval.
4. **Tract Map Term of Approval.** In accordance with the Subdivision Map Act, the recordation of the final map shall occur within two (2) years from the approval date unless an extension is granted. The applicant may apply for a maximum of five (5) one-year extensions, to permit additional time to record the final map. A written request for extension shall be submitted to the Development Services Department at least thirty (30) days prior to the expiration of Tentative Map approval.
5. **Val Verde School District.** The proposed subdivision shall adhere to the standard requirements and mitigation fees established by the *Val Verde School District*.

Exhibit A- Conditions

6. **ADA Compliance.** The project shall conform to all disabled access requirements in accordance with the State of California, Title 24, and Federal Americans with Disabilities Act (ADA).
7. **Property Maintenance.** The project shall comply with provisions of Perris Municipal Code 7.06 regarding Landscape Maintenance, and Chapter 7.42 regarding Property Maintenance.
8. **Indemnification.** The developer/applicant shall indemnify, protect, defend, and hold harmless, the City and any agency or instrumentality thereof, and/or any of its officers, employees and agents from any and all claims, actions, or proceedings against the City, or any agency or instrumentality thereof, or any of its officers, employees and agents, to attack, set aside, void, annul, or seek monetary damages resulting from an approval of the City, or any agency or instrumentality thereof, advisory agency, appeal board or legislative body including actions approved by the voters of the City, concerning **TTM 36647 (16-05216) ZC 15-05218, GPA 15-05217**. The City shall promptly notify the developer/applicant of any claim, action, or proceeding for which indemnification is sought and shall further cooperate fully in the defense of the action.
9. **Building Official/Fire Marshal.** The proposed project shall adhere to all requirements of the Building Official/Fire Marshal. Fire hydrants shall be located on the project site pursuant to the Building Official. The applicant shall submit a fire access and fire underground plan prior to construction drawings. Water, gas, sewer, electrical transformers, power vaults and separate fire/water supply lines (if applicable) must be shown on the final set of construction plans pursuant to the requirements of the Building Official. All Conditions of Approval shall be included on building plans. See City of Perris website, Office of the Fire Marshal, for examples and relevant information for access and underground plan available at: <http://www.cityofperris.org>.
10. **Fish and Game Fee.** Within three (3) days of City Council approval, the applicant shall submit a check to the City Planning Division, payable to "Riverside County Clerk-recorder," for payment of State Fish and Game fees and County documentary handling fee. In accordance with Section 711.4 of the State Fish and Game Code, no project shall be operative, vested, or final until the filing fees have been paid.
11. **Public Works Administration Conditions.** The project shall comply with all requirements of the Public Works Administration Department as indicated in the Conditions of Approval dated July 3, 2020.
12. **Engineering Conditions.** The project shall comply with all requirements of the City Engineer as indicated in the Conditions of Approval dated July 13, 2020.
13. **Fire Marshall Conditions.** The project shall comply with all requirements of the Fire Marshall as mentioned below:

- a. All homes in the cul-de-sac where the street is longer streets than 150 feet shall have full fire sprinkler protection throughout all attic space. Since this conditions is outside the normal fire code allowance an alternated Means & Methods request pursuant to CFC 104.9 shall be submitted to the City Fire Marshal for review and approval prior to the issuance of a grading permit.
 - b. A fire department access roads complying with the California Fire Code Chapter 5 and approved plans shall be installed prior to building construction.
 - c. All required fire hydrants shall be installed and operational prior to building construction. All fire hydrants shall remain operational during construction. All required fire hydrants shall be readily visible and immediately accessible. A clear space of not less than 3-feet shall be maintained.
14. **Building Conditions.** The project shall comply with all requirements of the Building Official as indicated in the conditions of approval dated June 11, 2020.
 15. **Community Services Conditions.** The project shall comply with all requirements of the Community Services department as indicated in the conditions of approval dated October 31, 2018.
 16. **Class II Bike Lane.** A Class II bike lane shall be installed per the *Perris Trail Master Plan* along Evans Road to all off-site improvement plans subject of the approval of Planning Division and City Engineer. A copy of the street improvement plans shall be submitted to the Planning Division.
 17. **Dam Inundation Disclosure.** The owner shall disclose to all future tenants indicating the project is in a dam inundation area making the site subject to flooding in the event of a dam failure.
 18. **Unit Identification.** Each unit in the tract shall include an interior lighted address fixture. This fixture shall allow for replacement of the bulbs, and shall be reviewed and approved by the Planning Division.
 19. **Utilities.** All utilities such as cable TV and electrical distribution lines (including those which provide direct service to the project site and/or currently exist along public right-of-ways) adjacent to the site shall be placed underground, except for electrical utility lines rated at 65kv or larger. All utility facilities attached to buildings, including meters and utility boxes, shall be painted to match the wall of the building to which they are affixed. These facilities shall also be screened from the public right-of-way by landscaping.
 20. **Mechanical Equipment.** All mechanical equipment, including air conditioning units, pool equipment, etc., shall be screened from the public right-of-way by a view obscuring fence, wall, or landscaping to the satisfaction of the Planning Division.

21. **Residential Use and Development Restrictions.** The physical development of all lots shall be reviewed and approved by the city. Any use, activity, and/or development occurring on the site without appropriate city approvals shall constitute a code violation and shall be treated as such. Placement of any sales trailer or a model home shall require separate review and approval by the City.
22. **Spark Arresters.** All spark arresters in the proposed tract shall be screened by sheet metal enclosures, or other material acceptable to the Building Department, and painted the according to the approved paint palette.
23. **City-Approved Waste Hauling.** The developer shall use only the City-approved waste hauler for all construction and other waste disposal.
24. **Energy Conservation.** To improve local air quality, the applicant shall incorporate the following energy-conservation features into the project (as feasible):
 - Low NO_x water heaters per specifications in the Air Quality Attainment Plan;
 - Heat transfer modules in furnaces;
 - Light colored water-based paint and roofing materials;
 - Passive solar cooling/heating; and,
 - Energy efficient appliances and lighting.

An accounting of the project's energy conservation measures shall be submitted to the Building Division, prior to application for Building Permits.

25. **Preliminary Water Quality Management Plan (PWQMP)** A Preliminary WQMP was prepared for the proposed project site. All P-WQMPs were determined to be in substantial compliance, in concept, with the Riverside County 2012 WQMP Manual requirements. The following two conditions apply:
 - a. The development shall be subject to all provisions of City of Perris Ordinance Number 1194, which establishes stormwater/urban runoff management and discharge controls to improve water quality and comply with federal regulations, and any subsequent amendments, revisions, or ordinances pertaining thereto.
 - b. The structural BMPs selected for this project have been approved in concept. The owner shall submit a final WQMP including plans and details providing the elevations, slopes, and other details for the proposed structural BMPs including the lot specific LID design, extended detention basins, and landscaping. The Public Works Department shall review and approve the final WQMP text, plans and details.

Prior to Final Tract Map Approval.

26. **Final Tract Map Approval.** Prior to issuance of grading permits, a final map application shall be submitted to the Planning Division with payment of appropriate fees for review and approval concurrently with application to the City Engineer. No precise grading permit shall be approved prior to final tract map approval. The developer shall obtain the

following clearances or approvals prior to Final Map Recordation:

- a. Verification from the Planning Division that all pertinent conditions of approval have been met, including any Administrative Development Plan Review approvals, as mandated by the Perris Municipal Code.
 - b. Planning Commission approval of all proposed street names through a Street Name application.
 - c. Prior to final map, the developer shall include a description that Perry Street (between Perris Valley Storm Channel to Evans Road) is vacated with the Final Tract Map.
 - d. Any other required approval from an outside agency.
 - e. **Community Facilities District No. 2018-02 (public services district).** The project shall be annexed into the Public Services District (Community Facilities District 2018-02).
 - f. **Assessment and Community Facilities Districts.** The project shall be annexed into any assessment, community facilities, or similar district that provides funding for maintenance, services, or public improvements that benefit the project. The costs and benefits shall be described in the applicable district and annexation documents. The developer shall complete all actions required to complete such annexation prior to issuance of a Certificate of Occupancy. This condition shall apply only to districts existing at the time the project is approved (or all requirements have been met for a certificate of occupancy, as applicable). Such districts may include but are not limited to the following:
 - i. Landscape Maintenance District No. 1;
 - ii. Flood Control Maintenance District No. 1;
 - iii. Maintenance District No. 84-1;
 - iv. Perris North Public Safety Community Facilities District 2001-3; and
 - v. Transportation Uniform Mitigation Fee.
 - vi. Community Facilities District No. 2018-02 (public services district)
27. **Access to Perris Valley Storm Channel Trail.** Prior to recordation of the final parcel map, the developer shall dedicate land, provide easements, or otherwise hold property in common ownership for access points to the pedestrian/bicycle trail along the PVSC western boundary of the project site. One access point will be located along the proposed Tract Map (36647) located as per the conceptual landscape plan exhibit. Wayfinding/Kiosk signage shall be provided at all entrances from the Perris Valley Storm Channel. A break in the fence shall be provided at each access point, and include the installation of removable bollards to prevent entrance of motorized vehicles.
28. **CC&Rs.** Prior to recordation of the Final Map, the developer shall submit and obtain approvals for any Covenants, Conditions, and Restrictions (CC&Rs) to establish an HOA to the Department of Development Services and the City Attorney's office. Approved

CC&Rs shall be recorded with the final map.

Prior to Issuance of Grading Permits

29. **Southern California Edison.** Prior to issuance of grading permits, the applicant shall contact the Southern California Edison (SCE) area service planner to complete the required forms prior to commencement of construction.
30. **Final Water Quality Management Plan (F-WQMP).** The development shall be subject to all provisions of City of Perris Ordinance Number 1194, which establishes stormwater/urban runoff management and discharge controls to improve water quality and comply with federal regulations, and any subsequent amendments, revisions, or ordinances pertaining thereto. The structural BMPs selected for this project have been approved in concept. The owner shall submit a final WQMP including plans and details providing the elevations, slopes, and other details for the proposed structural BMPs including the bioretention basin, detention basin, self-retaining landscaping, and roof drains to vegetation. The Public Works Department shall review and approve the final WQMP text, plans and details.
31. **Floodway.** Prior to receiving a building permit, no residential units shall not be developed within Floodway unless otherwise approved by FEMA. All building pads shall be a minimum of 12" inches and finished floors shall be elevated a minimum of 18 inches above the 100-year flood plain.

Prior to Issuance of Building Permits

32. **Building Plans.** All Planning, Public Works Administration, and Engineering Conditions of Approval shall be copied onto the approved building plans. Such conditions shall be annotated, directing the receiver to the sheet and detail(s) indicating satisfaction of the conditions. Also, the Mitigation and Monitoring Reporting Plan (MMRP) shall be listed and included with the "General Notes" on the construction drawings, and implemented in accordance with the timeline, reporting and monitoring intervals listed in the MMRP.
33. **Property Liens.** The applicant shall pay all liens owed to the city prior to the issuance of building permits.
34. **Administrative Development Plan Review.** Prior to issuance of any building permit, the applicant shall obtain approval of an Administrative Development Plan Review (ADPR) for the review of architecture, plotting, conceptual landscape, and fencing of all production units within the entire tract. The applicant shall provide one single-story product type which shall be plotted on corners and at regular intervals throughout the tract (i.e., every fourth or fifth unit). Side entry garages are encouraged and shall be incorporated as feasible and as approved through the development plan review process. The following is required for plotting, color and materials, and architecture.
 - a. The developer shall submit a minimum of four (4) architectural types, six (6) or

- b. more color schemes, and a minimum four (4) floor plans.
 - b. Each architectural type shall provide a minimum of two (2) materials that are associated with selected architecture.
 - c. All elevations shall provide architectural detail option for lots that are facing the public right-of-way, detention basins, Trails, and Perris Valley Storm Channels.
 - d. The floor plan shall include the garage is set back behind 5' feet or more from the habitable building wall or covered porch entry.
 - e. No three (3) consecutive lots (side by side) shall have similar architecture or floor plan, and no similar architecture or floor plan shall be located across the street.
 - f. A minimum 10% of each floor plan shall be used within the tract.
 - g. All garage doors shall include decorative windows at the top row of the door.
 - h. All units are required to provide a covered porch towards the street.
 - i. Roof type and roof pitch of new residential buildings shall be consistent throughout the architectural type.
 - j. Two story homes will break first and second story by recessing the second story or by providing an architectural feature that would distinguish each story from one another.
 - k. All units shall include accent features such as sills, shutters, false canopies, surrounds, and multi-paned windows shall be used. Recessed windows shall also be used where appropriate.
 - l. All electrical panels and exposed roof pipes shall be painted to match.
35. **Phasing.** Prior to issuance of building permits, all phasing plans shall be reviewed and approved by the Planning Division, and the City Engineer. Each Phase of the project shall provide adequate drainage and at least two points of access to all lots.
36. **March Air Reserve Base.** Prior to building permit issuance, in accordance with conditions of approval by the Airport Land Use Commission (ALUC) letter dated October 18, 2018, the following measures shall be implemented to address the project's location within Airport Influence Area:
- a. Any outdoor lighting installed shall be hooded or shielded to prevent either the spillage of lumens or reflection into the sky. Outdoor lighting shall be downward facing.
 - b. The following uses shall be prohibited:
 - i) Any use which would direct a steady light or flashing light of red, white, green or amber colors associated with airport operations toward an aircraft engaged in an initial straight climb following takeoff or toward an aircraft engaged in a straight final approach toward a landing at an airport, other than an FAA-approved navigational signal light or visual approach slope indicator.
 - ii) Any use which would cause sunlight to be reflected towards an aircraft engaged in an initial straight climb following takeoff or towards an aircraft engaged in a straight final approach towards a landing at an airport.
 - iii) Any use which would generate excessive smoke or water vapor or which would attract large concentrations of birds, or which may otherwise affect safe air navigation within the area. (such uses include landscaping utilizing water features,

aquaculture, production of cereal grains, sunflower, and row crops, artificial marshes, wastewater management facilities, composting operations, trash transfer stations that are open on one or more sides, recycling centers contain putrescible wastes, construction and demolition debris facilities, fly ash disposal and incinerators.)

iv) Any use that would generate electrical interference that may be detrimental to the operation of aircraft and/or aircraft instrumentation.

- c. A "Notice of Airport in the Vicinity" shall be provided to all potential purchasers and tenants of the property and shall be recorded as a deed notice. The disclosure is as follow:

NOTICE OF AIRPORT IN VICINTIY

"This property is presently located in the vicinity of an airport, within what is known as an airport influence area. For that reason, the property may be subject to some of the annoyances or inconveniences associated with proximity to airport operations (for example: noise, vibration, or odors). Individual sensitivities to those annoyances can vary from person to person. You may wish to consider what airport annoyance, if any are associated with the property before you complete your purchase and determine whether they are acceptable to you".

- d. The proposed water detention and/or infiltration basins or facilities shall be designed so as to provide for a detention period for the design storm that does not exceed 48 hours and to remain totally dry between rainfalls. Vegetation in and around the retention basin(s) that would provide food or cover for bird species that would be incompatible with airport operations shall not be utilized in project landscaping.
- e. March Air Reserve Base must be notified of any land use having an electromagnetic radiation component to assess whether a potential conflict with Air Base radio communication could result. Sources of electromagnetic radiation include radio wave transmission in conjunction with remote equipment inclusive of irrigation controllers, access gates, etc.

37. **Walls and Fences.** Prior to issuance of building permits, the developer shall submit and obtain approval form the Planning Division of a block wall/ fence plan. At a minimum, this plan shall include the following items:

- a. **Decorative Perimeter Walls.** The perimeter walls shall consist of a 6' foot high split-face block wall with decorative cap along Evans Road, southern tract boundary, and interior detention basins (in public view and facing interior trails) shall include split-face block wall with stone veneer pilasters every 60' feet or perimeter wall corner, or lot line corner.
- b. **Decorative Perimeter Walls (facing Perris Valley Storm Channel).** The perimeter walls shall consist of a 6' foot high split-face block wall with decorative cap with stone veneer pilasters every 60' feet or perimeter wall corner, or lot line

corner along the *Perris Valley Storm Channel*. The retaining wall below the split faced perimeter wall (facing the storm channel) shall use a decorative crib wall.

- c. **Fencing (visible from public view).** A six-foot high, decorative block wall shall be required for all residential property lines where side or rear yards adjoin a public street. This shall include decorative stone veneer pilasters. Split-face block walls with vinyl gates shall be used for all side returns between residences and along all side yards adjacent to a street.
 - d. **Interior fencing (not visible from public view).** Six-foot high, u.v. protected vinyl fence on side and rear property lines interior to the project (not visible from the public right-of-way).
 - e. **Height of Block Walls.** All split face walls shall not be higher than 6' feet in height. If a combination wall exceeds 6' feet, then a landscape berm or retaining wall is required to conceal the height of the wall.
 - f. **Corner/Reverse Corner and Rear Walls.** The decorative block walls shall be setback 5' (five) feet from the property line on all corner lots and reverse frontage lots that abut onsite public streets.
 - g. **Detention Basins and Storm Drain Facilities.** All enclosed detention basins or storm drain facilities shall have decorative wrought iron fencing with decorative pilasters every 60' feet or perimeter wall corner, or lot line corner. If the detention basin abuts a residential property, a 6' foot decorative block wall is required.
 - h. **East Basin.** The east basin perimeter fencing shall be subject to the Public Works conditions of approval and Evans Road Cross Section.
 - i. **Tract Identification.** The developer shall provide community entry statements, including theme walls, monumentation and enhance landscaping at each entrance to the tract along Evans Road. Theme walls and monuments shall not occur within the public right-of-way. The design of entry statements shall be subject to the review and approval of the Planning Division.
 - j. **Graffiti.** All tract perimeter block walls shall be treated with a graffiti resistant coat. This includes walls facing the Perris Valley Storm Channel, northerly wall facing Moreno Valley, detention basin, and Evans Road.
38. **Construction Practices.** To reduce potential noise and air quality nuisances, the following items shall be listed as "General Notes" on the construction drawings:
- a. Construction activity and equipment maintenance is limited to the hours between 7:00 a.m. and 7:00 p.m. Per Zoning Ordinance, Noise Control, Section 7.34.060, it is unlawful for any persons between the hours of 7:00 p.m. of any day and 7:00 a.m. of the following day, or on a legal holiday, or on Sundays to erect, construct, demolish, excavate, alter or repair any building or structure in a manner as to

- create disturbing excessive or offensive noise. If any deviations from the construction hours are deemed necessary, it first must be requested with the building inspector identifying why this must occur and the time frame it is needed along with necessary provision to mitigate noise impact. The approval of this request is subject to the review and approval of the Building Official.
- b. Building Department Construction activity shall not exceed 80 dBA in residential zones in the City.
 - c. Construction routes are limited to City of Perris designated truck routes or otherwise approved by the Building Official.
 - d. Water trucks or sprinkler systems shall be used during clearing, grading, earth moving, excavation, transportation of cut or fill materials and construction phases to prevent dust from leaving the site and to create a crust after each day's activities cease. At a minimum, this would include wetting down such areas in the later morning and after work is completed for the day and whenever wind exceeds 15 miles per hour.
 - e. A person or persons shall be designated to monitor the dust control program and to order increased watering as necessary to prevent transport of dust off-site. The name and telephone number of such persons shall be provided to the City.
 - f. Project applicant shall require contractor to provide construction site electrical hook ups for electric hand tools such as saws, drills, and compressors as practical to eliminate the need for diesel powered electric generators or provide evidence that electrical hook ups at construction sites are not practical or prohibitively expensive.
39. **Water Resources Control Board.** Prior to issuance of Building Permits, the applicant shall submit a copy of the State Water Resources Control Board permit letter with the WDID number to Planning Staff.
40. **Fees.** The developer shall pay the following fees according to the timeline noted.
- Prior to the issuance of building permits, the applicant shall pay:
- a. Stephen's Kangaroo Rat Mitigation Fees of \$500.00 per acre;
 - b. Multiple Species Habitat Conservation Plan fees currently in effect;
 - c. Current statutory school fees to all appropriate school districts;
 - d. Any outstanding liens and development processing fees owed to the City;
 - e. Prior to the issuance of building permits, The developer shall pay all development impact fees, including parks and recreation fees in accordance with Ordinance Number 953. Such fees shall be based on a ratio of five acres per thousand residents. Per said ordinance the City reserves the right to utilize fair market value of the land based on qualified appraisal;
 - f. Appropriate City Development Impact Fees in effect at the time of development (to include any community services DIF fees and Perris Valley ADP fees);
 - g. Appropriate Transportation Uniform Mitigation Fees (TUMF) in effect at the time of development; and

h. Park Facility Fees.

41. **Additional Plan Requirements.** The following additional plans shall be reviewed and approved by Planning staff and the appropriate City departments, as necessary:

- a. **Detached sidewalks.** The entire tract shall provide detached sidewalks within the right-of-way.
- b. **Landscape Maintenance District Areas.** The following areas shall be included in the Landscape Maintenance District:
 - i. Evans Road Parkway
 - ii. Main entrances from Evans Road
 - iii. All Detention basins within TM 36647
 - iv. The Perris Valley Storm Channel Trail or designated by Community Services.
 - v. All interior decompose granite trails and points of trail access from Evans Road and Perris Valley Storm Channel.
 - vi. Entry monument signage.
- c. **Block Wall Fencing (to include crib walls) along Perris Valley Storm Channel.** A maximum 6-foot high split-face block wall with pilasters every 60' feet or perimeter wall corner, or lot line corner shall be provided along the westerly property line. The wall shall provide graffiti based coating.

42. **Landscaping Plans.** Prior to issuance of building permits, three (3) copies of Construction Landscaping and Irrigation Plans shall be submitted to the Planning Department for approval and shall be accompanied by the appropriate filing fee. The landscape and irrigation plan shall be prepared by a registered landscape architect and conform to the requirements of Chapter 19.70 of the Municipal Code. The location, number, genus, species, and container size of the plants shall be shown. The landscaping shall be consistent with the conceptual landscape plan. The following shall apply:

- a. **Accent Landscaping.** The following treatments, consistent with the conceptual landscape plan or as conditioned herein, are required:
 - Shade trees (are required along the Perris Valley Storm Channel and entry trail connection points.
 - Large trees (36" box) shall contribute to the landscape design at all main entrances to the project site.
- b. **Street Trees.** All street trees shall be 24-inch box size or larger, and planted a maximum of 30 feet on center within the parkway. Corner lots have three (3) street trees, minimum or one (1) street tree for every 30 lineal feet of street frontage.
- c. **Parkway Landscape and Irrigation.** All parkways shall be provided with landscape and automatic irrigation.
- d. **Front Yard Trees.** A minimum of two (2) fifteen (15) gallon front yard trees shall be provided for each residential lot.
- e. **BMPs for Water Quality.** All BMPs (vegetated swales, detention basins, etc.) shall be indicated on the landscape plans with appropriate planting and irrigation.

- The detention basins shall provide minimum 24" inch box trees with shrubs or combination with ground cover. Perennial grass mix is prohibited.
- f. **Corner/Street Side and Reverse Frontage Lots.** A 5' (five) foot setback behind the property line adjacent to the block wall shall be required to consist of decorative hardscape to include: cemented river rock, and decomposed granite (2 colors) with boulders subject to the review and approval of the Planning Division. Except for those areas designated under an LMD per Public Works requirements shall be landscaped with irrigation.
 - g. **Slopes.** Slopes that are 3:1 or steeper and 4 feet or higher, shall have one approved tree for every 400 square feet, with 70% of trees 10 gallon sized, and 30% being 5 gallon sized. All slopes shall include automatic irrigation and erosion control fabric.
 - h. **Water Conservation.** Landscaping must comply with AB 325 for water conservation or other current policy or regulation at such time of development. See Chapter 19.70 (cityofperris.org) for water conservation calculations (MAWA).
 - i. **Maintenance.** All required landscaping shall be maintained in a viable growth condition.
 - j. **Irrigation Rain Sensors.** Rain sensing override devices shall be required on all irrigation systems (PMC 19.70.040.D.16.b) for water conservation. Soil moisture sensors are required.
 - k. **Landscape Inspections.** The project applicant shall inform the on-site project manager and the landscape contractor of their responsibility to call for final landscape inspection after all the landscaping and irrigation have been installed and is completely operational. Before calling for final inspections a "Certificate of Compliance" form shall completed and signed by the designer/auditor responsible for the project, and this form must be submitted to the project planner. The project planner will need to sign off on the "Certificate of Compliance" to signify code compliance.

Prior to Issuance of Occupancy Permits:

- 43. **Disclosure Statements.** Developer shall record a disclosure on each lot and provide a disclosure to the purchaser of each lot that the project is within a dam inundation area and is subject to flooding in the event of a dam failure and shall provide an acknowledgement of this disclosure by each purchaser to the City. A similar disclosure shall be made in recognition of potential noise impacts from March Air Reserve Base and the aviation easement granted to the City of Perris and to the March Inland Port Airport Authority.
- 44. **Perris Valley Storm Channel Trail Improvements and Landscaping.** The trail improvements and landscaping shall be subject to the *Community Services* Conditions of Approval dated October 31, 2018.
- 45. **Final Inspection.** The applicant shall obtain occupancy clearance from the Planning Division by scheduling a final Planning inspection after final sign-offs from the Building Division and Engineering Department. Planning Staff shall verify that all Conditions of Approval have been met.



CITY OF PERRIS

STUART E. MCKIBBIN, CITY ENGINEER

CONDITIONS OF APPROVAL

P8-1317

September 19, 2018, Revised December 20, 2018,

Revised July 13, 2020

TTM 36647, ZC 16-05218, & GPA 16-05217

With respect to the Conditions of Approval for the above referenced project, the City of Perris requires that the land divider provide the following street improvements and/or road dedications in accordance with the City of Perris Municipal Code Title 18. It is understood that the map correctly shows all existing easements, traveled ways, and drainage courses with appropriate Q's and that their omission may require the map to be resubmitted for further consideration. These Ordinances and the following conditions are essential parts and requirement occurring in ONE is as binding as though occurring in all. They are intended to be complimentary and to describe the conditions for a complete design of the improvements. All questions regarding the true meaning of the conditions shall be referred to the City Engineer's office.

1. ***In order to provide for economic earth balance for the tract, the developer has proposed to borrow fill material from the "Remainder Lot" shown on the Tentative Tract Map.***

The proposed borrow site is deemed to be acceptable since, said lot had been designated by City Council as a detention basin as part of the San Jacinto River Plan - Alternative 5 - through adoption of Resolution No. 3403 on May 10, 2005.

Without additional flood control infrastructure, the borrow site will not function as a basin. Moreover, the grading of the borrow site must conform with the Riverside County Flood control and Water Conservation District

(RCFCD) restrictions and conditions, per the attached Exhibit "A".

The borrow site shall be identified as a legal lot on the Tract Map 36647 and shall be offered for dedication to the City for flood control purposes.

Also the borrow site does not confer any benefit to the future homeowners of Tract 36647, therefore the developer shall bear the full burden of both funding and the long-term maintenance of the borrow site and the associated dewatering pump until it is improved to RCFCD standards and accepted by either the City or RCFCD for maintenance as a detention basin. The developer or its successor, can fulfill this responsibility by being a permanent member of the Home Owners' Association (HOA), until the borrow site is accepted by RCFCD for maintenance.

2. **The "Combination Access Road and Community Trail" shall be identified as a legal lot on the Tract Map 36647 and shall be offered for dedication to the City for community trail purposes.**
3. Drainage and flood control facilities and improvements shall be provided in accordance with Riverside County Flood Control and Water Conservation District and the City of Perris requirements and standards. The following drainage related conditions are the requirements of this project:
 - a. Onsite drainage facilities located outside of right-of-way if required shall be constructed within dedicated drainage easements. Any work within Riverside County Flood Control right-of-way requires their review and approval.
 - b. The property's street and lot grading shall be designed in a manner that perpetuates the existing natural drainage patterns with respect to tributary drainage area. No ponding or concentration of water to upstream and downstream properties shall be permitted.
 - c. All drainage facilities with exception of nuisance drainage improvements as indicated below shall be designed to convey the 100-year storm runoff. At all new and existing intersections (on and offsite), minimum 18" storm drain and catch basins to eliminate nuisance runoff from cross-gutter shall be installed and connected to existing and proposed storm drain facilities.

- d. A detailed hydrology report and hydraulic calculation shall be submitted to the City for review and approval. The report shall address the offsite flow, accumulative onsite runoff and the impact to adjacent downstream properties.
- e. All grading and drainage improvements shall comply with NPDES and Best Management Practices. Erosion control plans shall be prepared and submitted to Water Quality Board and the City as part of the grading plans.
- f. This project is located within the mapped 100-year flood plain. Prior to issuance of any permit, the Conditional Letter of Map Revision (CLOMR) shall be submitted. Prior to issuance of any building permits, the final Letter of Map Revision (LOMR) shall be submitted.

Minimum pad elevation must be 12" higher than calculated 100-year flood plain.

- g. Dedication of additional right-of-way along the east side of Perris Valley Channel per adopted master plan shall be required. All improvements within this channel shall be reviewed by Planning Department.
4. Improvements to Evans Road between Ramona Expressway and north City limits shall be in general conformance to City Standards, however the following additional improvements will be required:
- Reference is made to Webb & Associates' memorandum dated March 22, 2016 and the City of Moreno Valley Traffic Engineer's letter dated May 29, 2015. The applicant shall be required to implement the recommended improvements stipulated in these letters and as shown on conceptual plans prepared by Webb titled "Evans Road Ultimate Geometric and Safety Improvements". These and following improvements including the traffic signal at intersection of Evans Road and Balserra Gate shall be implemented prior to issuance of any occupancy permits.
 - The memorandum prepared by Webb also references traffic report prepared by RK and previously reviewed by the City Council. The RK report recommend installation of a fence along the median to discourage "J-walking". The City Council has determined that the installation of fence along the median is not appropriate.

- The project applicant shall work with School District to implement the recommendation of the traffic report and the Webb memorandum as feasible. It is also required for the applicant to work with City of Moreno Valley and install the improvements required by City's Traffic Engineer.
- Access shall be restricted to right-in and right-out at "A" Street and "C" Street.
- Access shall be restricted on Evans Road and noted on Final Map.
- The intersection of "C" Street/Marbella Gate with Evans Road shall be reconstructed in a manner to prohibit left turn movements. This is accomplished by construction of new median.
- The existing pavement along the west side of Evans Road adjacent to the site shall be grind/overlay.
- Additional pavement improvements shall be provided along Evans Road due to utility trenches as determined by City Engineer.
- Construct new crosswalk and pedestrian traffic signal at the EMWD easement located in the City of Moreno Valley. Improvements to include median improvements to serve as a pedestrian refuge and pedestrian signal.
- Construct new traffic signal at the existing intersection of Belserra Gate and Evans Road with associated intersection striping to provide crosswalks. Crosswalk striping shall be Continental Striping.
- Re-stripe Evans Road from Ramona Expressway to northerly City limits to reduce lane widths to 11'.
- Continental striping at all proposed and existing school crosswalk locates include Belserra Gate/Evans Road intersection, new pedestrian crossing in the City of Moreno Valley, and Via De Anza/Evans Road intersection.
- Construct pedestrian lighting improvements at crosswalks at the intersection of Belserra Gate and Evans Road.
- Install additional signage extending school reduced speed limit zones south in to the City of Perris per the California MUTCD.

- Install traffic signal interconnect on Evans Road from Ramona Expressway to Via de Anza.
 - Modify existing traffic signal at Anira Court and Evans Road to accommodate shifted lane and bike lanes.
 - Modify existing traffic signal at Ramona Expressway and Evans Road to accommodate shifted lanes and bike lanes. Install southbound overlapping right turn signal per the traffic impact analysis for TTM 36648.
 - Pay cash-in-lieu fair share for cumulative improvements (3rd westbound through lane and westbound overlapping right turn signal) as identified in the traffic impact analysis.
 - In-roadway warning light system shall be installed at all new/existing crosswalks along Evans Road without a signal.
5. All easements and/or right-of-way dedications shall be offered for dedication to the public and shall continue in force until the City accepts or abandons such offers. All dedications shall be free from all encumbrances as approved by City.
 6. Relinquish and waive right of access to and from Evans Road on the Final Map with the exception of two (2) opening at "A" Street and "C" Street as delineated on the approved Tentative Map.
 7. Vehicular movements at "A" Street and "C" Street at Evans Road shall be restricted to right-in/right-out only.
 8. Onsite drainage facilities located outside of road right-of-way shall be contained within drainage easements and shown on the Final Map. A note shall be added to the Final Map stating: "Drainage easements shall be kept free of buildings and obstructions."
 9. The developer shall design and guarantee construction (i.e., posting of security and entering into agreements) of the following public improvements (including parkways and raised landscaped medians) to City's standards unless otherwise noted. Plans shall be approved by City. All street improvement designs shall provide adequate right-of-way and pavement transitions per Caltrans' standards to join existing street improvements.
 10. Improve Evans Road – Arterial Highway (128'/94') from Ramona Expressway to northerly tract boundary to include dedication of

half-width street right-of-way, installation of half-width street improvements, new paving, curb and gutter, sidewalk, streetlights, drainage facilities, signing and striping and utilities (including but not limited to water and sewer), 14' wide raised landscaped median and offsite pavement transition from northerly tract boundary to existing pavement section on Evans Road per Caltrans and City Standards.

In the event that Department of Water Resources (DWR) implements and constructs the Evans Road Crossing prior to construction of Evans Road, the developer will then be required to coordinate and install the necessary improvements to join and match DWR improvements.

In the event DWR has not started any such work, the applicant shall transition Evans Road improvements as stated above and terminate at northerly DWR right-of-way. The applicant shall also pay cash in-lieu to guarantee completion of Evans Road improvements in the event DWR abandons their project. This fund will be reimbursed to applicant upon completion of improvements by DWR or developers.

11. "A", "B", "D", "E", "F", "G", "H" and "I" (60'/40') streets shall be improved with curb/gutter located 20' on either side of centerline within 60' dedicated right-of-way.
12. "C" Street (78'/44') shall be improved with curb/gutter located 22' on either side of centerline within 78' dedicated right-of-way.
13. "F" and "H" Streets northerly terminus shall be improved with turn arounds, as approved by Fire Department, in the adjacent property (TTM 36648-1), if TM 36648-1 improvements are not in place; respective easements shall be obtained.
14. Streetlights shall be installed along all interior streets and Evans Road as approved by the City Engineer per City of Perris standards. The lights shall be LS3, LED and plans prepared by Registered Electrical Engineer.
15. Overhead wires/cables (65 Kv or less) shall be removed and undergrounded, poles relocated.
16. 6' wide concrete sidewalk shall be installed throughout this project as approved by Planning Department.
17. The proposed development is in the service area of Eastern Municipal Water District. The applicant shall provide water and

sewer facilities to this development and comply with EMWD, Fire Department, and Health Department's requirements.

18. Prior to issuance of any permit, the developer shall sign the consent and waiver forms to join the landscaping, flood control, street maintenance, and lighting districts. The developer shall maintain the landscaping for a period of one year after acceptance of these improvements and pay the 18-month advanced energy charges for streetlights. All storm drain facilities including basins, catch basins, and pipes shall be annexed to Flood Control District.
19. On and offsite street, drainage, water, sewer, striping, signing, streetlight, grading, and erosion control plans along with hydrology and hydraulic reports shall be submitted to the City Engineer's office for review and approval.
20. The street design and improvement concept of this project shall be coordinated with the adjacent projects.
21. Open spaces/trails and basins shall be reviewed and approved by Planning Department.
22. Additional traffic calming improvements including signing/striping as recommended by applicant's Traffic Engineer shall be installed throughout the project.



Stuart E. McKibbin
City Engineer

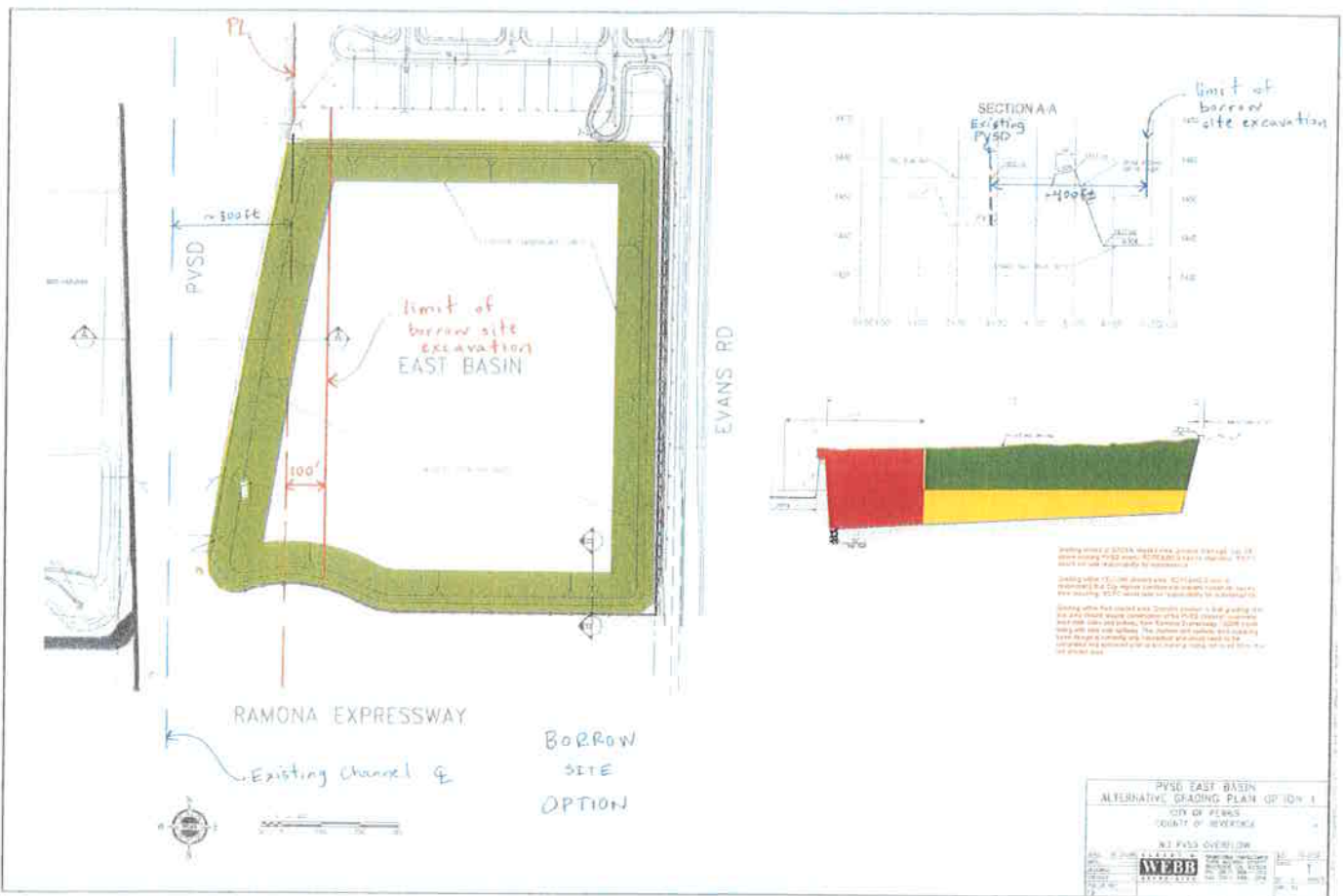

limit of borrow site excavation EAST BASIN

100'

PVSD

RAMONA EXPRESSWAY

Existing channel &

EVANS RD

BORROW SITE OPTION

SECTION A A

Existing PVSD

400'

limit of borrow site excavation

Red

Green

Yellow

PVSD EAST BASIN
ALTERNATIVE GRADING PLAN OPTION 1
CITY OF PERKASIE
COUNTY OF BERKS

W. E. WEBB
REGISTERED PROFESSIONAL ENGINEER
No. 100,000,000
PA. REG. NO. 100,000,000



Memorandum

To: Habib Motlagh, City of Perris
Nathan Perez, City of Perris

From: Dilesh Sheth, P.E., T.E. *Dilesh Sheth*

Date: March 22, 2016

Re: TTM36647 and TTM36648 Safety and Roadway Improvements along Evans Road



The purpose of this memo is to provide recommendations for roadway and safety improvements for Evans Road for Stratford Ranch Residential (TTM36647 and TTM36648). Phase 1 of development of Stratford Ranch is the proposed TTM36648. Phase 2 is TTM36647. The recommendations are based on the Traffic Impact Analysis conducted for TTM36647 and TTM36648 along with an analysis of the current safety conditions of Evans Road, particularly in regards to pedestrians.

Existing Conditions

Evans Road

Currently, Evans Road is a 2 to 3 lane in each direction primary arterial with a 14' raised median. It connects north with Lasselle Street in the City of Moreno Valley, a 2 lane in each direction arterial with an 18' raised median. According to the Stratford Ranch (TTM36648) Traffic Impact Analysis, Evans Road, near the location of Rancho Verde High School, currently carries approximately on average 21,000 vehicles daily. The current speed limit is 55 MPH on Evans Road in the City of Perris between Ramona Expressway and the City limit and 50 MPH north of Rancho Verde High School in the City of Moreno Valley. The City of Perris has adopted a master bike plan for the City of Perris, which includes implementing bike lanes along Evans Road. The City of Moreno Valley has designated between the City limit and Via De Anza as a bike route. There are currently no bike lanes along Evans Road between Ramona Expressway and Via De Anza. The primary land use or zoned land use along Evans Road is residential, except at the intersection with Ramona Expressway, where there is a future commercial development planned.

Rancho Verde High School & Pedestrians

RK Engineering performed the Rancho Verde High School Traffic/Circulation Review in October 2009. The school was originally designed for a student population of approximately 2,400 students but in 2009, the student population was approximately 3,300 students with a staff of approximately 250 employees. The school built new facilities to accommodate students but the amount of parking has only decreased over the years. The review pointed to the inadequacy of the on-site circulation with only one fully functioning access point from Lasselle Street. The review also observes mid-block "jaywalking" as a major safety concern because "parents park on the west side of Lasselle Street in a southbound direction."

PM counts, 25 pedestrians were observed jumping the fence at the school's southern driveway and 74 pedestrians were observed jaywalking just south of where the fence ends at Camino Delrey. Attached to this memo are the counts collected.

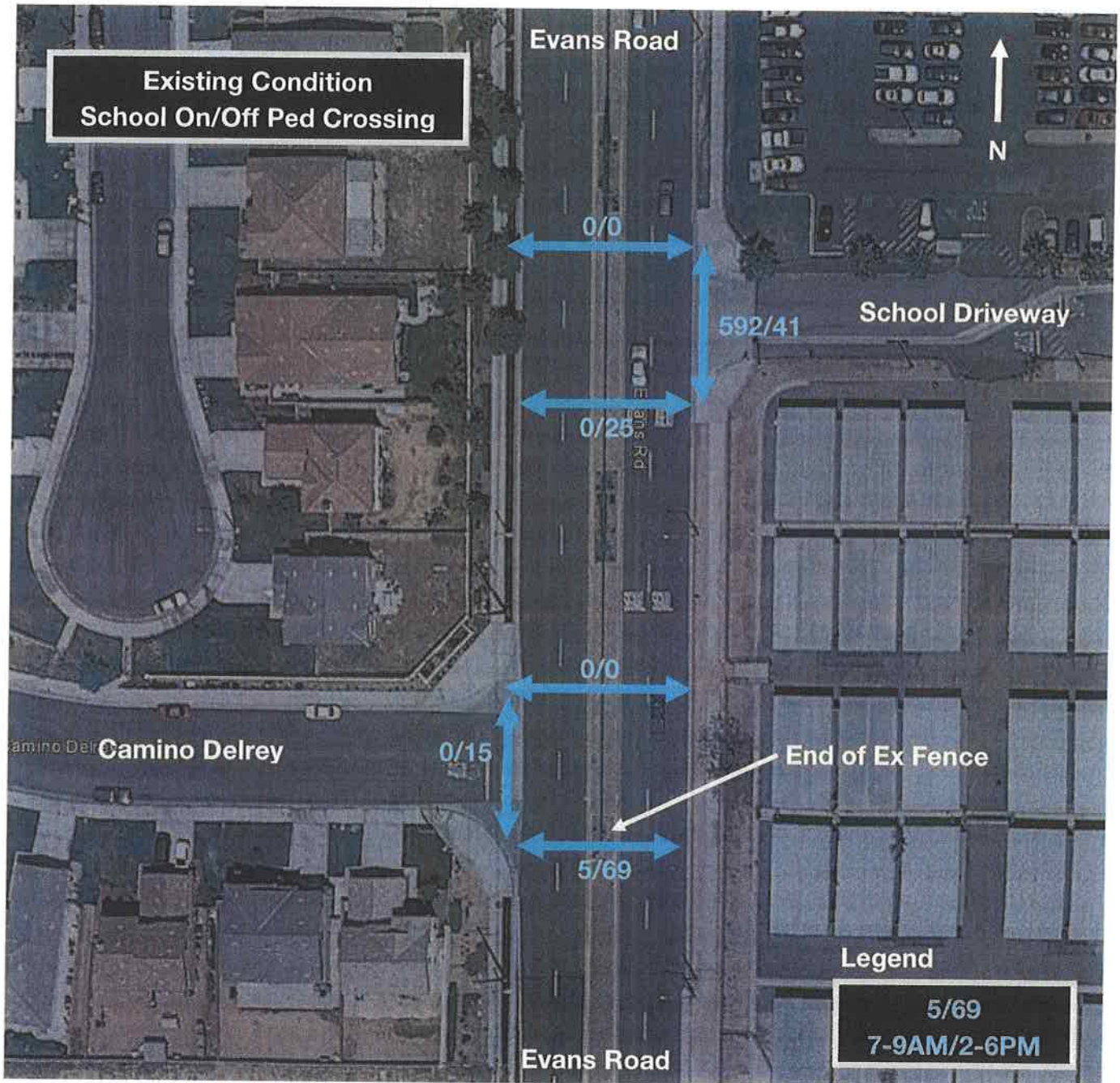

Figure 1: Existing Pedestrian Counts during School On & Off periods at Camino Delrey and School Driveway

Project and Future Conditions

With the addition of the proposed Stratford Ranch (TTM36648) and other cumulative projects in the area, Evans Road is predicted to operate on average 26,500 vehicles a day.

The Stratford Ranch residential project proposes providing the existing ultimate right-of-way for Evans Road as designated in the General Plan and providing 2 through lanes in each direction, bike lanes, and a right turn lane. The right turn lane is proposed to be designed so that in the future, the City can decide if necessary to restripe the right turn lane into a through lane and would not have to perform any additional street improvements. This is in contrast with the City's request for 3 through lanes in the southbound direction, bikes lanes and a right turn lane.

Pedestrian Safety

Collisions with Pedestrians

According to the Federal Analysis Reporting System, a data resource website for the National Highway Traffic Safety Administration, 69% of pedestrian fatalities are at non-intersection locations. These are the locations where pedestrians are not expected and cars travelling at full speed can cause fatalities.¹

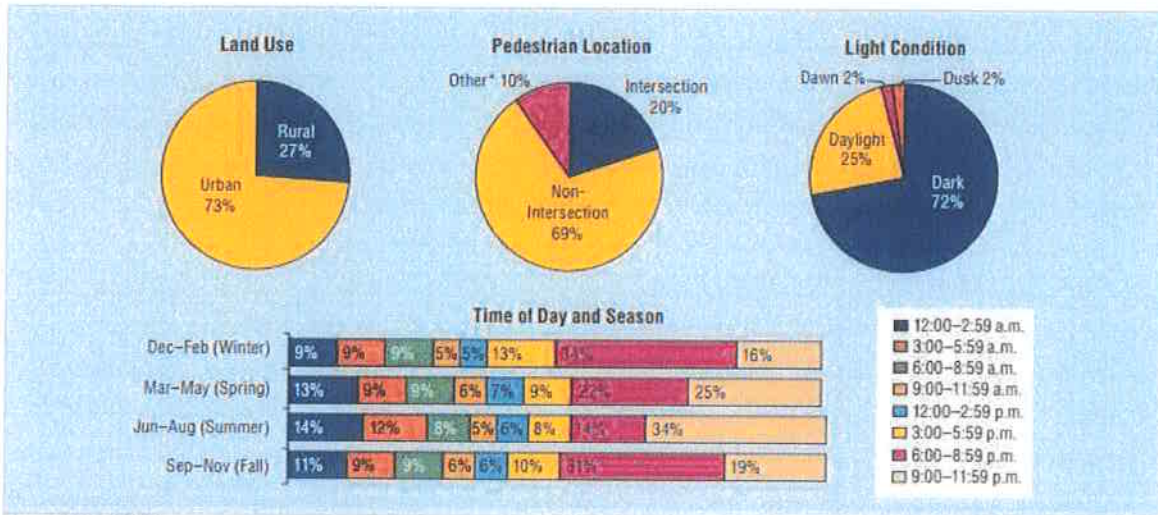

Source: FARS 2013 ARF.

Note: Unknown values were removed before calculating percentages.

*Other includes parking lane/zone, bicycle lane, shoulder/roadside, sidewalk, median/crossing island, driveway access, shared-use path/trail, non-trafficway area, and other.

Figure 2: Percentage of Pedestrian Fatalities in Relation to Land Use, Pedestrian Location, Light Condition, and Time of Day and Season. Source FARS 2013.

There's a high correlation with pedestrian fatalities and the speed of the motor vehicle. Figure 3 from the Traffic Advisory Unit analyzes the probability for fatal, injury-causing, or with no injury accidents, dependant on vehicle speed. The probability for fatality dramatically decreases from approximately 85% with 40 MPH to approximately 5% with 20 MPH. In San Francisco, between 2005 and 2011, 90% of pedestrian fatal collisions were with vehicles traveling at 55 MPH.²

¹ National Highway Traffic Safety Administration. FARS 2013 ARF Pedestrian Collisions Data.

² San Francisco Planning Department. "WalkFirst: Making San Francisco safer one step at a time." Accessed March 27, 2015. <<http://walkfirst.sfplanning.org/index.php/>>

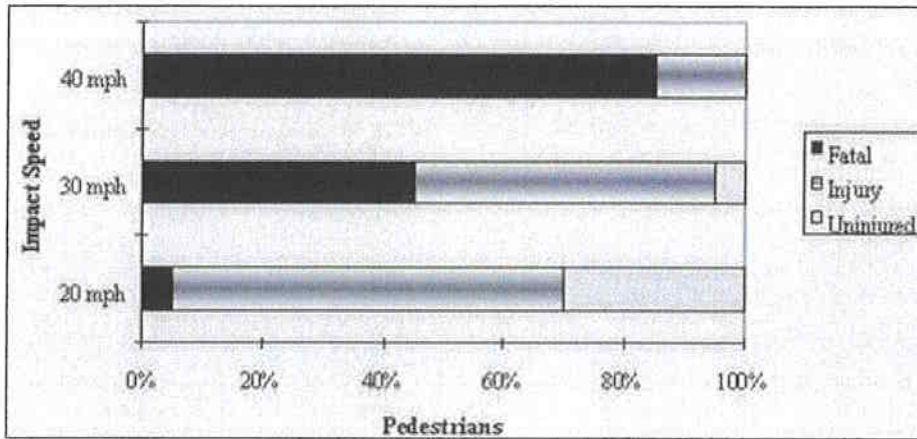

Figure 3: Pedestrian Injury Severity Based on Vehicle Speed. Source: Traffic Advisory Unit, 1993.

Figure 4 from the Transportation Authority of Marin and republished by Safe Routes to School, shows the increasing distance of number of feet motorists will need in order to stop a car. As the speed increases, the distance needed increases.³

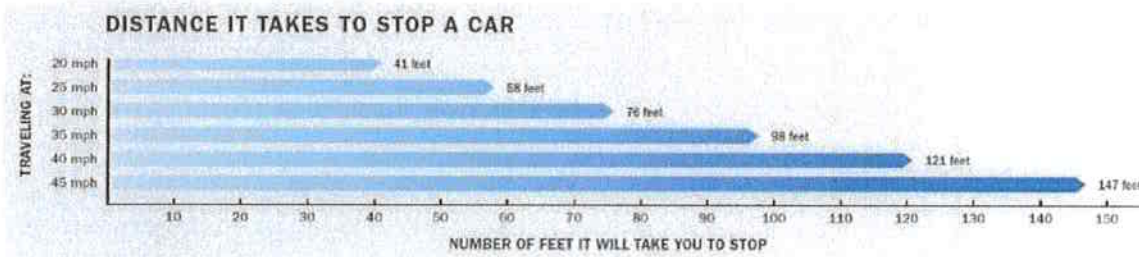

Figure 4: Travel Speed vs. Reaction and Braking. Source: Street Smarts Marin, Transportation Authority of Marin

ITE advises that physical changes to roadways to achieve traffic calming are generally more self-enforcing than traditional education and enforcement efforts and offer long-term benefits and do not require continued intervention. Physical changes to roadways suggested include curb extensions, chicanes, lateral shifts, and chokers, speed humps, speed tables and raised crosswalks, raised intersections, neighborhood traffic circles/mini-traffic circles, half-street closures, median islands, and forced-turn islands. In particular with curb extensions, the publication cites reducing roadway width from curb to curb as one way to shorten crossing distance for pedestrian and make it easier for motorists to see pedestrians, which both improve pedestrian crossing safety.⁴

Possible Recommendations for Improving Pedestrian Safety

Proposals based on Rancho Verde High School Traffic Review

RK Engineering in the Rancho Verde High School Traffic Review made many recommendations to improve the on-site and off-site circulation. On and off-site circulation improvements would improve pedestrian safety

³ Institute of Transportation Engineers. "Safe Routes to School Briefing Sheets: The Use of Traffic Calming Near Schools."

⁴ Institute of Transportation Engineers. "Safe Routes to School Briefing Sheets: The Use of Traffic Calming Near Schools."

for Evans Road. On-site improvements would encourage parents to turn into the school and use the on-site drop off locations instead of choosing to drop kids off on the street. One such recommendation is the connection with Lake Perris Drive to encourage use of the secondary right-in-right-out driveway south of the main driveway.

An off-site recommendation made for Evans Road is to extend the existing median fence south of the existing fence as far as possible to prohibit pedestrians from crossing Lasselle Street.⁵ The fence currently ends just south of the Camino Del Rey intersection with Evans, by the border of the City of Perris and the City of Moreno Valley. Pedestrian counts at the Camino Del Rey intersection show 69 people crossing at that location during the afternoon hours.

Proposal based on TTM36648

Based on the above review of pedestrian safety, three lanes would be safer for pedestrians than four lanes. In addition, the California Manual on Uniform Traffic Control Devices (MUTCD) has designated the pedestrian walking speed to be 3.5 feet per second. Therefore on a 94' wide roadway (as proposed by TTM36648), pedestrians would take 27 seconds to cross the road. Adding an additional lane, as proposed by the City, would require an 106' wide roadway and 30 seconds to cross the road.

If lanes were reduced to be 11' through lanes, motorists are likely to drive slower and there would be space for other potential pedestrian or bicycle improvements. Furthermore, according to the FHWA, a reduction in vehicle interactions resulting from a road diet can decrease the number and severity of crashes.⁶ According to San Francisco's WalkFirst program, a program that seeks to reduce serious and fatal injuries in San Francisco, lists road diets as one of their safety tools to encourage drivers to reduce vehicle speeds. Road diets eliminate a lane or more of travel.⁷

Figure 5: Median Island Pedestrian Refuge Crossing. Source: FHWA



Proposals based on Literature Review

Median Islands – Median Refuge

Median islands can be used as a median refuge for pedestrians crossing wide roads. "The Federal Highway Administration (FHWA) strongly encourages the use of raised medians (or refuge areas) in curbed sections of multi-lane roadways in urban and suburban areas, particularly in areas where there are mixtures of a significant number of pedestrians, high volumes of traffic (more than 12,000) vehicles per day) and intermediate or high travel speeds."⁸

⁵ RK Engineering. "Rancho Verde High School Traffic Review." October 7, 2009.

⁶ FHWA. "Public Roads: Going on a Road Diet." Accessed March 26, 2015.
<www.fhwa.dot.gov/publications/publicroads/11septoct/05.cfm>

⁷ San Francisco Planning Department. "WalkFirst: Making San Francisco safer one step at a time." Accessed March 27, 2015.
<<http://walkfirst.sfplanning.org/index.php/>>

⁸ FHWA. "Safety Benefits of Raised Medians and Pedestrian Refuge Areas." February 2013.

Mid-block Crossing

According to the NACTO Urban Street Design Guide, “midblock crosswalks facilitate crossings to places that people want to go but that are not well served by the existing traffic network. These pedestrian crossings, which commonly occur at schools, parks, museums, waterfronts and other destinations, have historically been overlooked or difficult to access, creating unsafe or unpredictable situations for both pedestrians and vehicles.”⁹ A mid-block crossing has the potential of addressing the pedestrian crossing demand and focusing them at a central location. They are incentivized to cross at this location because pedestrians feel safer in a marked crosswalk. Mid-block crossings should be designed with some of the following proposals to improve the safety.

Curb Extension

A curb extension can also be coupled with a crosswalk to reduce the pedestrian crossing distance, increase pedestrian and driver visibility. The longer the pedestrian crossing distance, the longer pedestrians are in the street, the longer the delay on vehicular traffic and the greater the probability for accidents.

Figure 6: Midblock crossing curb extensions provide better visibility for motorists and pedestrians. Source: FHWA

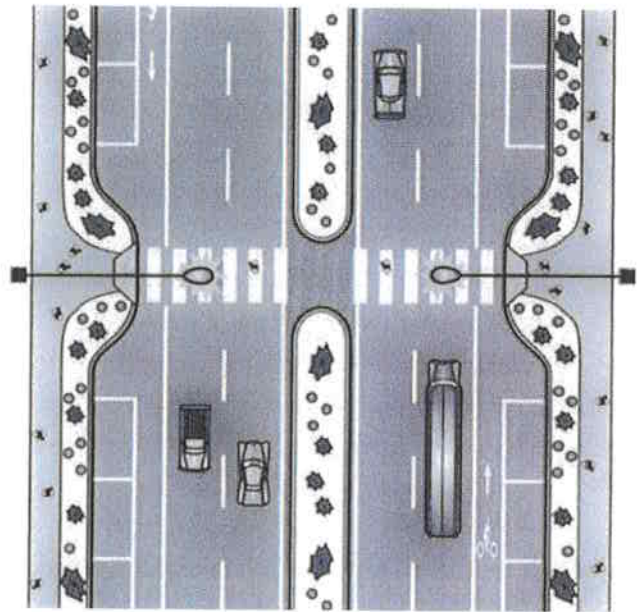

Pedestrian Beacon/Signals

A pedestrian crossing without a traffic signal can also be signalized with flashing beacons, a hybrid beacon, a conventional traffic signal and/or a pedestrian actuated signal device with a locator tone for pedestrians with vision impairments.¹⁰ According to the FHWA, the installation of pedestrian hybrid beacons reduced pedestrian crashes by 69 percent. Their study suggests a 19 percent reduction in total crashes and severe crashes was reduced by 15 percent.¹¹

Raised Crosswalk

An additional option is to vertically raise the crosswalk. The raised crosswalk would provide level street crossing and also make pedestrians more visible to approaching motorists. For vehicles the raised crosswalk would also operate as a speed table to slow drivers down for the 25 MPH reduce speed limit zone. According to Fehr & Peers, speed tables on average see a 45% decrease in accidents.¹² The raised crosswalk would be coupled with signs to warn drivers.

High-Visibility Crosswalks

The visibility of crosswalks can be enhanced through striping. Figure 5 shows various crosswalk treatments including the high-visibility crosswalk treatments. Crosswalk treatments are inexpensive and provide a better

⁹ NACTO. "Urban Street Design Guide." Accessed March 26, 2015. <nacto.org>

¹⁰ FHWA. "Designing Sidewalks and Trails for Access: Best Practices Design Guide." Accessed March 26, 2015. <www.fhwa.dot.gov/environment/bicycle_pedestrian/publications/sidewalk2/sidewalks208.cfm>

¹¹ FHWA. "Pedestrian Hybrid Beacon Guide – Recommendations and Case Study." March 2014.

¹² Traffic Calming.org. Accessed March 26, 2015. <trafficalming.org>

visual queue of where pedestrians could be crossing. The continental crosswalk can be designed to avoid wheel paths and reduce long-term maintenance needs.¹³

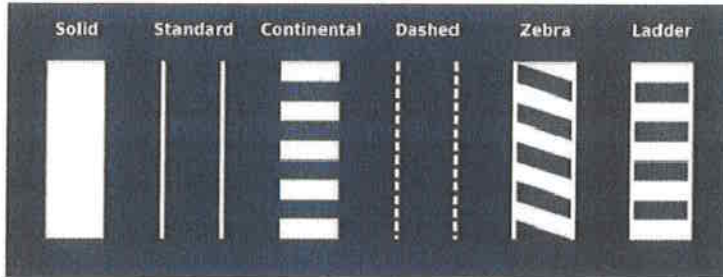

Figure 7: High-Visibility Crosswalk Treatments. Source: SFbetterstreets.org

Pedestrian Lighting

Lighting for crosswalks and for pedestrian walkways improve the safety and security for both traffic and for pedestrians crossing sidewalks. According to FARS 2013, 72% of collisions happen at night.¹⁴ Therefore lighting crosswalks and mid-block crosswalks can greatly reduce the probability of collisions.

Reduced Speed Limit Zone

Currently the speed limit zone starts at the City of Moreno Valley and City of Perris limit, but according to the suggested distance from the California MUTCD and ITE and SRTS Publication on Reduced School Area Speed Limits, the suggestion is 200 feet in advance of the school grounds.¹⁵

| School Speed Limit (mph) | Distance to Crosswalk or First Driveway (ft.) |
|--------------------------|---|
| 20 | 200 |
| 25 | 200 |
| 30 | 300 |
| 35 | 400 |

Figure 8: Suggested beginning of school speed limit zone. Source: Institute of Transportation Engineers (ITE)

Application

Improvements by Rancho Verde High School

This memo recommends that Rancho Verde High School implements the recommendations made by RK Engineering for improving school on-site circulation. Without improvements by the school, the current unsafe travel patterns are only going to continue or can grow worse. On-site circulation can be improved for example through a direct connection to Lake Perris Drive, as mentioned in the memo made by RK Engineering.

Improvements by TTM36648

The following is a summary of the possible improvements listed above that have direct application and are recommended for improving pedestrian safety along Evans Road in connection with the Rancho Verde High School. Other improvements listed here that are not mentioned above are roadway improvements tied to the forecasted traffic from the development. Refer to the attached Evans Road exhibit for details.

¹³ SFBetterStreets.org. "A guide to making street improvements in San Francisco." Accessed March 27, 2015. <www.sfbetterstreets.org/>

¹⁴ National Highway Traffic Safety Administration. FARS 2013 ARF Pedestrian Collisions Data.

¹⁵ Institute of Transportation Engineers. "Safe Routes to School Briefing Sheets: The Use of Traffic Calming Near Schools."

1. Install a traffic signal at the intersection of Belserra Gate and Evans Road with appropriate striping as early as possible, before TTM36648, to facilitate safe crossing at this location.
2. Extend the median fence to Belserra Gate to discourage pedestrians from crossing at non-crosswalk marked locations and cross instead at the signal to be installed.
3. Maintain Evans Road as 2 through lanes in each direction in front of the residential tracts per TTM36648's recommendations.
4. Reduce lane widths to 11' to reduce motorists' speed and allocate additional street space for bike lanes and an expanded bike lane buffer. Refer to the attached Evans Road exhibit for details.
5. A new crosswalk at the EMWD easement's future trail crossing, south of the Camino Delrey intersection, with:
 - a. An opening in the pedestrian fence for this crosswalk,
 - b. Median improvements to serve as a pedestrian refuge, and
 - c. Pedestrian signal or warning beacon to warn motorists of pedestrians.
6. Continental striping at all proposed and existing school crosswalks.
7. Pedestrian lighting improvements especially at crosswalks.
8. Modify the existing Marbella Gate intersection to right-in-right-out to reduce potential conflicting turning movements along Evans Road by extending the median through the intersection.
9. Extend school area reduced speed limit zones south into the City of Perris per the California MUTCD.
10. Interconnect traffic signals on Evans Road from Ramona Expressway to Via de Anza and synchronize the signals at 45 MPH.
11. Update the traffic signal at Anira Court and Evans Road to accommodate shifted lanes and bike lanes. The traffic signal at Ramona Expressway would also need to be updated along with the installation of a southbound overlapping right turn signal per the traffic impact analysis for TTM 36648.
12. Reconfigure Evans Road median to create left turn pockets as shown in the Evans Road exhibit attached.
13. Pay cash-in-lieu fair share for cumulative improvements as identified in the traffic impact analysis for TTM36647.

A second phase of improvements associated with the **TTM36647** (just south of TTM36648) are listed below.

1. Widen Evans Road to the ultimate cross section from the southerly line of Tract 32708 to the northerly DWR easement line. This improvement will require the relocation of 6 existing SCE power poles. Refer to the Evans Road exhibit for geometrics.
2. Restripe Evans Road from the southerly line of Tract 32708 to Ramona Expressway with bike lanes, buffer and reduced lane widths. Refer to the attached Evans Road exhibit for details.

3. Update traffic signal at Ramona Expressway and Evans Road as necessary to accommodate shifted lanes and bike lanes.
4. Construct full width median along Evans Road.
5. Pay cash-in-lieu fair share for cumulative improvements as identified in the traffic impact analysis for TTM36647.

Improvements by City of Perris and City of Moreno Valley

1. Implement no parking signs except residents in adjacent residential tracts.
2. To encourage safe behavior and discourage dangerous behavior for motorists and for pedestrians, increased police enforcement may be necessary. Police enforcement should enforce the following:
 - a. Pedestrians jaywalking across Evans. Guide them to the new and improved crosswalks,
 - b. Vehicles stopping along Evans Road, and
 - c. Speeding particularly within 200 feet of the school grounds during school hours.

Citation

1. Dan Burden and Peter Lagerwey, "Road Diets: Fixing the Big Roads," (Walkable Communities, Inc., 1999).
2. Erik Rosen and Ulrich Sander, "Pedestrian Fatality Risk as a Function of Car Impact Speed."
3. Fatality Analysis Reporting System (FARS) Encyclopedia, 2013.
4. FHWA. "Evaluation of Lane Reduction 'Road Diet' Measures and Their Effects on Crashes and Injuries" (Highway Safety Information System, 2010).
5. FHWA. "Designing Sidewalks and Trails for Access: Best Practices Design Guide." Accessed March 26, 2015.
<www.fhwa.dot.gov/environment/bicycle_pedestrian/publications/sidewalk2/sidewalks208.cfm>
6. FHWA. "Public Roads: Going on a Road Diet." Accessed March 26, 2015.
<www.fhwa.dot.gov/publications/publicroads/11septoct/05.cfm>
7. Institute of Transportation Engineers. "Safe Routes to School Briefing Sheets: The Use of Traffic Calming Near Schools."
8. NACTO. "Urban Street Design Guide." Accessed March 26, 2015. <nacto.org>
9. RK Engineering. "Rancho Verde High School Traffic Review." October 7, 2009.
10. Traffic Calming.org. Accessed March 26, 2015. <trafficcalming.org>

Appendix

1. Evans Road Intersection Exhibit
2. Counts from Counts Unlimited performed in May 2014

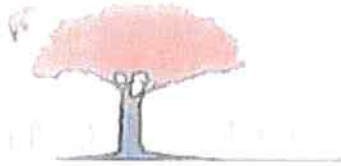

May 29, 2015

City of Perris
135 North "D" Street
Perris, CA 92570-1998

Attention: Clara Miramontes, Director of Development Services

RE: Evans Road Corridor Improvements

Dear Ms. Miramontes:

The City of Moreno Valley appreciates the opportunity to provide input for the proposed corridor improvements on Evans Road between Ramona Expressway and Camino Del Rey. Based upon our review, we offer the following suggested revisions:

1. Revise striping layout to remove the acceleration lanes. Removing the acceleration lanes will reduce unnecessary weaving conflicts for both motorists and cyclists thereby improving traffic operations along the corridor.
2. Consider using 11-foot lanes as a means of reducing vehicle speeds throughout the corridor. Studies have demonstrated that narrower travel lanes on urban arterial roadways improve safety for all users. The resulting additional street width can be absorbed using buffered bike lanes and / or median adjacent striping.
3. Consider 8-foot bike lanes throughout the corridor. This width allows two cyclists to ride comfortably adjacent to each other, allows more operating space to avoid debris, and affords the opportunity for riders to pass slower cyclists, all within the bike lane.
4. Move proposed pedestrian signal from Lasselle Street / Camino Del Rey approximately 155 feet southerly. This location will provide an enhanced crossing opportunity for students attending Rancho Verde High School, and provides better alignment for a future regional trail crossing leading to Lake Perris. A regional trail crossing at this location would serve both the City of Perris and Moreno Valley.
5. Evans Road is a regional arterial serving multiple agencies. Equipment (controllers, fiber optic communication, etc.) specified for all proposed traffic signals along Evans Road should be compatible with the City of Moreno Valley Lasselle Street system. This will allow the traffic signals to communicate and operate as one system, thereby providing the opportunity for seamless coordination along the corridor. Additionally, if video surveillance cameras are installed at key locations as part of the system, Moreno Valley would offer to actively manage the traffic flow through our Transportation Management Center.

Evans Road Corridor Improvements
5/29/15
Page 2

6. Restrict access at the intersection of Evans Road / Marbella Gate to right in/out by extending / reconfiguring the existing raised median. This will eliminate the need for a future traffic signal, and will improve operations / reduce collisions resulting from vehicles crossing multiple lanes from an uncontrolled intersection. Residents desiring to turn left from the adjacent residential communities can be accommodated at Anira Court with minimal inconvenience.
7. Consider dual lefts for the southbound movement into the future commercial center just north of Ramona Expressway. This will improve traffic flow / capacity at the intersection and will enhance channelization approaching Ramona Expressway.

We look forward to working with the City of Perris on these corridor improvements. If you have any questions or comments, or need additional information, please contact me at (951) 413-3149.

Sincerely,

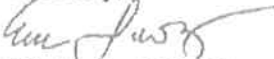

Eric Lewis, P.E., T.E.
City Traffic Engineer

EI

Cc: Habib Mollagh, City Engineer
Dilesh Sheth, Webb and Associates
Michael Lloyd, City of Moreno Valley



CITY OF PERRIS

PUBLIC WORKS DEPARTMENT

LANDSCAPE DIVISION

Weed Abatement

NPDES Services

Flood Control and Landscape Districts

MEMORANDUM

Date: July 3, 2020

To: Ryan Griffiths, Project Planner

From: Michael Morales, CIP Manager

Subject: Condition of Approval Tentative Tract Map (TTM) 36647. Conditions of Approval Proposed to only initiate development of 22.54 acres of the Stratford Ranch South Project (AKA Stratford Ranch Homes) involving 90 single family lots and two lettered lots (A&B), and a 28-acre off site drainage basin. The project is located south of associated TTM 36648, west along Evans Road, east of Perris Valley Storm Channel, North of Ramona Expressway and South of Moreno Valley City Limits (302-150-009 thru-019) PR 16-05216

1. Dedication and/or Landscape Maintenance Easement. Offer of Dedication and Landscape Maintenance Easement for City landscape maintenance district shall be provided as follows:

- **Evans Road**—Provide offer of dedication as needed to provide for full half width Street (64'), curb gutter, sidewalk and off-site landscaping requirements, per City General Plan, including minimum 17' public parkway from back of curb. Provide meandering sidewalk 6' sidewalk beginning at Lot 1 (Where Lot B intersects with the Evans Road right-of-way) and continuing south to the DWR property right-of-way.

2. Landscape Maintenance Easement and Landscape Easement Agreement. The developer shall provide, for review and approval, a landscape easement, complete with legal plat map and legal description to the City of Perris. The Developer shall provide an additional 4' landscape easement and Landscape easement agreement, acceptable to the City of Perris for continuation of the Perris Valley Storm Drain Channel Trail along Evans Road, continuing south to the DWR property right-of-way. The total public parkway and PVSD Trail along Evans Road will be 21' from back of curb. Construct trail in accordance with City of Perris Trail Master Plan and plans drawn by Webb and Associates for Perris Master Plans for exact location and construction for asphalt bike trail and decomposed granite trail and planting plan. The City shall record the same with the Riverside County Recorder's Office, and the recorded instrument shall be returned to the City Clerk of the City of Perris for filing.

3. Landscaping Plans. Three (3) copies of Construction Landscaping and Irrigation Plans for the off-site landscaping, including any medians or other landscape areas along the dedications shall be submitted to the Planning Department for approval and shall be accompanied by the appropriate filing fee. The landscape and irrigation plan shall be prepared by a registered landscape architect and conform to the requirements of Chapter 19.70 of the Municipal Code. The location, number, genus, species, and container size of the plants shall be shown. This landscape plan shall be titled " Off-site Landscape Plan For TTM 36647" and shall be exclusive of any private

property, on-site landscaping. Elements of the Landscape Plan shall include but not be limited to:

a. Landscape Limits – Limits of right-of-way areas or easement areas, defined by concrete mow curb, fully dimensioned, that are to be annexed into the Landscape Maintenance District. A planting palette and hardscape plan intended to meet the design intent of the Landscape Guidelines in effect for the area; or if no such guidelines exist the design intent of neighboring development, as determined by the Engineering Administration and Special Districts Division, including:

- **Evans Road** –Tree Primary: Ulmus Parvifolia-Chinese Elm; Secondary (accent tree): Platnus-Acerfolia-London Plane Tree. Use drought resistant shrubs and ground cover intended to complement the existing parkways to the east along Evans Road (BZ 70 TM 32707 and 32708), including but not limited to 1) Pittosporum Tobira Wheelers Dwarf, 2) Lilly of the Nile (Agapanthus Africanus), 3) Hemerocallis Hybrids (evergreen) "Evergreen Daylilly," 4) Trachelospermum Jasminoides, Star Jasmin, 5) cold hardy varieties of Lantana; and ground cover/vine, which do well in Perris including, : 1) Myoporum Pacificum 2) Rosemarinus O. Prostratus "Prostrate Rosemary, and 3) Parthenocissus Tricuspidata, Boston Ivy. Parkway will include 6' meandering sidewalk to match neighboring development, with 3-rail fence at back of concrete sidewalk separating bicycle path.
- **Master Trail Plan Along Western Edge of Tract to Lot B-** Provide a Landscape Design In accordance with the Class I Bike Path Facilities Design Guidelines, provided in the City of Perris Trails Master Plan.
- **Lot A Walking Path, Lot B Retention/Detention Basin, and Lot B Master Trail** - Provide a landscape design and planting pallet that compliments the selected plants for the retention basin, walking path and master trail design.
- **Evans Road Continuing South to DWR Right-of-way (Continuation of Perris Valley Storm Drain Trail)-** Provide a Landscape Design In accordance with the Class I Bike Path Facilities Design Guidelines, provided in the City of Perris Trails Master Plan. Modified, to include 6" curb at back of asphalt concrete bicycle path and wrought iron fencing along edge fronting basin.
- **Interior Street Parkways-Cul-de-sac** adjacent to Lot 4 at H & A streets; side yard Landscaping at Lots 3, 79, 80, 90, 89, 88, 87, 69 and 70.

b. Irrigation – A list of irrigation system components intended to meet the performance, durability, water efficiency, and anti-theft requirements for Special District landscape areas as determined by the Engineering Administration and Special Districts Division. Components shall include, but not be limited to Salco or GPH flexible PVC risers, Sentry Guard Cable Guard and Union Guard, and backflow Wilkens Model 375 (or equal). Controller shall include an ET based controller with weather station that is centrally controlled capable and wi-fi ready (Calsense or equal). At the discretion of the Engineering Administration and Special Districts Division public landscape areas utilizing no more than 6 valves/stations, programmed to irrigate consecutively, and none simultaneously, may propose the use of an alternative ET based controller with weather station that is centrally controlled capable and wi-fi ready, such as the Weathermatic System or equal. Proposed system shall be complete with wireless weather station, aircard with flow, one year bundle service, blade antenna and flow sensor.

c. Benefit Zone Quantities – Include a Benefit Zone quantities table (i.e. SF of planting areas, turf, number of trees, SF. of hardscape, etc.) in the lower right hand corner of the cover sheet for off-site landscape areas, indicating the amount of landscaping the district will be required to maintain.

d. Meters – Each District is required to be metered separately. All electrical and water meters shall be located in

locations that are easily accessible to maintenance staff while not visually obtrusive in the street scene and away from street intersections. Show location of separate water and electrical utility meters intended to serve maintenance district areas exclusively. Show locations of water and electrical meter for landscape district. Show location of water and electrical meter for flood control district. Show location of electrical meter for Traffic signal and street lighting district, on respective plans. Coordinate location of meters on landscape and civil engineering plan.

- e. **Controllers** - The off-site irrigation controllers are to be located within the right of way (preferably within the off-site landscape area). All point of connection equipment including irrigation controller pedestals, electrical meter pedestals, and backflow preventers are to be located in locations that are easily accessible to maintenance staff while not visually obtrusive in the street scene, and away from street intersections. Backflow preventers are to be screened on at least three sides with (5) gallon plant material. The fourth side shall be open to the back of the landscape area in order to allow the backflow cage to be opened without interference with plant materials. Backflow cages shall meet the required City of Perris Engineering Standards in effect at the time of approval.
 - f. **Recycled Water** - If applicable. The project landscape architect shall coordinate with EMWD to verify if the site will be served with recycled water and design all irrigation and landscape plans to meet the requirements of EMWD and provide additional irrigation components as needed.
 - g. **EMWD Landscape Plan Approval** – The project landscape architect shall submit a copy of all irrigation plans and specifications to EMWD for approval. The project landscape architect must confirm with EMWD that the plans have been approved by EMWD and submit written proof of approval by EMWD prior to the City approving the final Landscape Plans. Until the final landscape plan has been approved by the City of Perris, the maintenance areas depicted cannot be accepted by the City for maintenance. The developer shall coordinate the both reviews to ensure acceptability of plans by both EMWD and the City of Perris, prior to approval by either agency.
 - h. **Landscape Weed Barrier** - Weed cloth with a minimum expected life of 10-years shall be required under all mulched areas.
 - i. **Wire Mesh and Gravel At Pull Boxes**- Provide wire mesh and gravel layer within valve boxes to prevent rodent intrusion
4. **Landscape Inspections.** The project applicant shall inform the on-site project manager and the landscape contractor of their responsibility to call for only "OFF-SITE" landscape and irrigation inspections at the appropriate stages of construction. Inspections shall be scheduled at least two-working days (Monday through Friday) prior to actual inspection. Contact Public Works-Engineering Administration/Special Districts at (951) 657-3280 to schedule inspections.
- **Inspection #1** - Trenches open, irrigation installed, and system pressurized to 150 PSI for four hours.
 - **Inspection #2** - Soil prepared, and plant materials positioned and ready to plant.
 - **Inspection #3** - Landscaping installed, irrigation system fully operational, and request for "Start of 1 year Maintenance Period" submitted, with all required turn-over submittal items provided to Public-Works Engineering Administration/Special Districts.
 - **Turn-Over Inspection**– On or about the one year anniversary of Inspection #3, Developer shall call for an inspection to allow the City to review and identify any potential irrigation system defects, dead

plants, weed, debris or graffiti; stressed, diseased, or dead trees; mulch condition, hardscape or other concerns with the landscape installation; or to accept final turn over of the landscape installation. At his sole expense, the Developer shall be responsible for rectifying system and installation deficiencies, and the one year maintenance period shall be extended by the City until all deficiencies are cured to the satisfaction of the City. If in the opinion of the City's Landscape Inspector the landscape installation is in substantial compliance with the approved landscaping plans, the irrigation and communication system is functioning as intended, and the landscape installation is found to be acceptable to the City, then the Inspector shall recommend to the City's Special District Coordinator to accept turn-over of water and electrical accounts, wi-fi communication contracts and the entire landscape installation.

5. **One Year Maintenance and Plant Establishment Period**-The applicant will be required to provide a minimum of a one (1) year maintenance and plant establishment period, paid at the sole expense of applicant. This one-year maintenance period commences upon the successful completion of Inspection #3 discussed above, and final approval by the City. During this one year period the applicant shall be required to maintain all landscape areas free of weeds, debris, trash, and graffiti; and keep all plants, trees and shrubs in a viable growth condition. Prior to the start of the one year maintenance period, the Developer shall submit a weekly Landscape Maintenance Schedule for the review and approval by the City's Special Districts Division. City shall perform periodic site inspections during the one-year maintenance period. The purpose of these periodic inspections is to identify any and all items needing correction prior to acceptance by the City at the conclusion of the one-year maintenance period. Said items needing correction may include but are not limited to: replacement of dead or diseased plant materials, weeding, replenishment of mulches, repair of damaged or non-functioning irrigation components, test of irrigation controller communications, etc. During this period, the City shall begin the annual assessment of the benefit zone in preparation for the landscape installation turn-over to City maintenance staff.
6. **Street/Off-Site Improvements.** The applicant shall submit street improvement plans, accompanied by the appropriate filing fee to the City Engineering Department. Details of treatments off-site improvements, including lighting shall meet both the City Engineer's Design Guidelines, and the additional requirements of the Engineering and Special Districts Division. Components shall include, but not be limited to:
 - a. **Street Lighting**-If street lighting is required, lighting shall meet the type, style, color and durability requirements, necessary for energy efficiency goals, maintenance and longevity of improvements of the City Engineer's Office. As determined by the City, new streetlights may be required to be deeded to City of Perris, and not SCE. Street lights deeded to City of Perris shall be constructed per LS-3 account billing standard, which shall include an individually metered pedestal for streetlights.
 - b. **Acceptance By Public Works/Special Districts**- Lighting District facilities required by the City Engineer's Office shall be installed and fully operational, and approved by final inspection by the City Engineer's Office, and the City's Consulting Traffic Signal Inspection Team (Riverside County TLMA) at (951) 955-6815. Prior to acceptance for maintenance of "Off-site" traffic signal and lighting facilities by the Public Works-Engineering and Administration Division/Special Districts, the developer shall contact the Public Works Special Districts Division at (951) 956-2120 to schedule the delivery of all required turn-over submittal items. Prior to acceptance into Lighting District 84-1, coordinate turn-over information pertaining to Street Lights, and Traffic Signal Electrical/SCE Service Meters with Wildan Financial Services, the City's Special Districts Consulting Firm at (951) 587-3564. (i.e. Provide electrical meter number, photo of pedestal, and coordinate "request for transfer of billing information" with SCE and City for all new service meters). Developer shall pay 18-month energy charges to the City of Perris for all off-site street lighting. Call Wildan Financial Services, Inc. for amount due, and to obtain receipt for payment. Obtain and provide a clearance form from Riverside County TLMA indicating completion of all punch list items from traffic signal construction. Submit one large format

photo-copy of Traffic Signal as-built plans and timing sheets.

7. **Water Quality Management Plans.** The applicant shall submit a Preliminary and Final WQMP, accompanied by the appropriate filing fee to the Planning Department and City Engineering Department, respectively. Details for treatment control facilities shall meet both the Riverside County WQMP Design Guidelines, and the additional requirements of the Engineering and Special Districts Division intended to reduce long term maintenance costs and longevity of improvements. Components shall include, but not be limited to:
 - **Storm Drain Screens-**If off-site catch basins are required by the City Engineer's Office, connector pipe screens shall be included in new catch basins to reduce sediment and trash loading within storm pipe. Connector pipe screens shall meet the type, style, and durability requirements of the Public Works Engineering Administration and Special Districts Division.
 - **WQMP Inspections-** The project applicant shall inform the on-site project manager and the water quality/utilities contractor of their responsibility to call for both "ON-SITE" and OFF-SITE" WQMP Inspections at the appropriate stages of construction. Contact CGRM at (909) 455-8520 to schedule inspections.
 - **Acceptance By Public Works/Special Districts-**Both on-site and off-site flood control/water quality facilities required for the project, as depicted in the Final WQMP, shall be installed and fully operational, and approved by final inspection by the City's WQMP Consultant, CGRM. The Developer shall obtain a final Clearance Letter from CGRM indicating compliance with all applicable Conditions of Approval for the approved WQMP. The developer shall deliver the same to the Public Works-Engineering and Administration Division/Special Districts. In addition, prior to acceptance by the City, the developer shall submit a Covenant and Agreement describing on-going maintenance responsibilities for on-site facilities per the approved WQMP, to the Public Works Engineering Administration and Special Districts Division. The Public Works Engineering Administration and Special Districts Division will review and approve the Covenant and Agreement. The City shall record the same with the Riverside County Recorder's Office, and the recorded instrument shall be returned to the City Clerk of the City of Perris for filing.
8. **Flood Control District #1 Maintenance Acceptance.** The proposed development will benefit from existing "downstream" flood control facilities, including pipe and catch basins, which serve the existing development. Therefore, the project shall annex into a new Flood Control District Benefit zone and pay its fair share for the maintenance of these downstream facilities. However, any "new" Flood Control District facilities required by the City Engineer's Office shall be installed and fully operational, and approved by final inspection by the City Engineer's Office. Prior to acceptance for maintenance of "Off-site" flood control facilities by the Public Works-Engineering and Administration Division/Special Districts the developer shall contact the Public Works Special Districts Division at (951) 657-3280 to schedule the delivery of all required turn-over submittal items including as-built storm drain plans in electronic PDF format, one large format photo-copy of as-built plans, storm drain video report in electronic format, and hardcopy of video report with industry standard notations and still photos made during video runs (i.e. facilities sizes, off-sets or damage, facility type, dirt and debris, etc.). The flood control facilities shall be turned over in a condition acceptable to the City, and the developer shall make all necessary repairs and perform initial maintenance to the satisfaction of the City.
9. **Assessment Districts.** Prior to permit issuance, developer shall deposit \$5,250 per district, \$15,750 total due. Payment is to be made to the City of Perris, and the check delivered to the City Engineer's Office. Payment shall be accompanied by the appropriate document for each district indicating intent and understanding of annexation, to be notarized by property owner(s):

- **Consent and Waiver for Maintenance District No. 84-1** - New street lighting proposed by the project, as determined by the City Engineer
 - **Consent and Waiver for Landscape Maintenance District No. 1** –New off-site parkway landscape within 17' right-of-way, and 4' easement for continuation of Master Trail along Evans Road to DWR right-of-way; Master Plan Trail within Lot B, Lots A & B retention/detention basin and walking path, interior street side yards at designated lots, and Master Plan Trail along western edge of TTM 36647.
 - **Petition for Flood Control Maintenance District No. 1** -New Drainage Facilities constructed for the project, as determined by the City Engineer.
downstream facilities.
-
- Original notarized document(s) to be sent to:
Daniel Louie
Wildan Financial Services
27368 Via Industrial, #200
Temecula, CA 92590
-
- a. Prior to final map recordation or final certificate of occupancy the developer shall annex into the aforementioned districts, posting an adequate maintenance performance bond to be retained by the City as required by the City Engineer. Upon receipt of deposit and Consent and Waiver Forms, the developer shall work with City to meet all required milestones for annexations.
 - i. City prepares the Engineer's Reports which includes a description of the improvements to be maintained, an annual cost estimate and annual assessment amounts.
 - ii. Reports are reviewed and approved by the property owner. The assessment ballots will be based on these Reports.
 - iii. The Reports and corresponding resolutions are placed, for approval, on the City Council Meeting Agenda. City Council action will include ordering the assessment ballots and setting a Public Hearing for no sooner than 45 days. Property owner attendance at this City Council Meeting is not required.
 - iv. The assessment ballots are sent to the property owner and are opened by the City Clerk at the close of the Public Hearing. With a "YES" vote by the property owner the City Council can move forward with the Resolution that Confirms the Annexation. Property owner attendance at this Public Hearing is not required.
 - v. Confirmation by the City Council completes the annexation process and the condition of approval has been met.

SRC COMMENTS
***** BUILDING & SAFETY *****

Planning Case File No(s): TTM 36647 (16-05216) ZC 16-05218, GPA 16-05217

Case Planner: Nathan Perez, at (951) 943-5003, ext. 279

Applicant: Jason Keller

Location: Located South of associated TIM 36648, west along Evan Road, east of the Perris Valley Storm Channel, North of Ramona Expressway and South of Moreno Valley City Limits.

Project: A proposal to subdivide 22.54 net acres into 90 single family lots and two (2) lettered lots (A, B), a General Plan Amendment to amend the project area from SP (Specific Plan) to R-6,000 from the City of Perris General Plan land use element, and a Zone Change to re-zone the project area from R-10,000 to R-6,000. UPDATED INFO: the project includes the 27 acre East detention basin.

APN(s): 302-150-009 thru -019

Reviewed By: David J. Martinez, CBO

Date: 6-11-2020

BUILDING & SAFETY

GENERAL CONDITIONS

- 1. Shall comply with the latest adopted edition of the following codes as applicable:
 - A. 2019 California Building Code
 - B. 2019 California Residential Code
 - C. 2019 California Electrical Code
 - D. 2019 California Mechanical Code
 - E. 2019 California Plumbing Code
 - F. 2019 California Energy Code.
 - G. 2019 California Fire Code
 - H. 2019 California Green Building Standards Code.
- 5. The Tract or Parcel map shall record prior to the issuance of any permits
- 6. The proposed new tract development will have to comply with the new electric vehicle charging station requirements per the adopted code.
- 7. The proposed new tract development will have to comply with the new Solar requirements per the adopted codes.
- 8. Permits are required prior to the removal and/or demolition of any structures.

PRIOR TO ISSUANCE OF BUILDING/CONSTRUCTION PERMITS

- 14. The following items shall be completed and/or submitted as applicable – prior to the

issuance of building permits for this project:

- A. Precise grading plans shall be approved
- B. Rough grading completed
- C. Compaction certification
- D. Pad elevation certification
- E. Rough grade inspection signed off

MEMORANDUM

101 North "D" Street, Perris, CA 92570

TO: Nathan Perez

FROM: Darren Madkin, Assistant City Manager *DM*

DATE: October 31, 2018

SUBJECT: TTM 36647, ZC 16-0528, GPA 16-05217

APPLICANT: Mission Pacific Land Company

Community Services Staff have reviewed TTM 36647 and offer the following comment(s):

- Ordinance Number 953 F.1-7 specifies that whenever a specific plan, tentative tract map, residential tentative parcel map, or multi-family residential development proposal is submitted to the Development Services Department, it must be accompanied by a written statement from the applicant stating their intention to dedicate land, pay fees in lieu thereof, or a combination of both for park and recreational purposes. **No such statement is included with this application. See attached condition.**
- The map or site plan for this project does not show the location of the proposed parkland dedication.
- The proposed parkland dedication is less than the amount of land required to be dedicated (5 acres/1000 residents). ____ acres are required, but the proposed parkland dedication is only _____. The developer/subdivider must pay fees for the value of any additional land that otherwise would have been required to be dedicated.
- The proposed parkland falls below the minimum size for a _____ park.
- The proposed parkland lies in a floodplain/floodway which impacts the available area for development of park improvements.
The following terms are recommended:
- Other: The household size has increased to 4.16 persons per household in Perris (2010 Census). This number should be used to calculate the park acreage required to meet the requirement. Facilities ineligible for park credit include landscaped area edges, medians, subdivision entries, lakes and streams, or other water features, paseos, greenbelts, trails, walkways, and other similar features that are used primarily as transportation corridors and are not destinations in and of themselves, and privately owned facilities (parks, community centers) which are smaller than four (4) acres.

1. Park Dedication Fee/ Calculation:

90 single family lots x 4.16 persons per household = 374
Dedication requirement is 5 acres per 1,000 residents
 $90/200 = 0.45$ acres

- Or -

The Developer may pay park fees in lieu of dedicating park acreage based on the fair market value of the land which would otherwise be required.

2. Perris Valley Trail Improvements and Landscaping:

The developer shall plan, acquire easements or licenses from the Riverside County Flood Control District, and construct a pedestrian trail along the east bank of the Perris Valley Storm Drain levee that will connect with the future Juan Bautista de Anza Trail (City of Moreno Valley) trail connection to the north of Tract 36648; and the Perris Valley Trail south of the project site. Developer should contact Alan Yasuda, Assistant Engineer with KOA Engineering at 2141 W Orangewood, Orange, CA 92868 (714) 573-0317 or (714) 923-6272; ayasuda@koacorp.com ; to coordinate connection to the City of Moreno Valley's Juan Bautista de Anza Trail. Developer shall also refer to the City of Perris Engineer's conditions of approval for specifications of improvements on Evans Road for bike lane striping.

The Developer shall construct a ten foot (10') wide asphalt concrete pathway for bicycling and a four and a half foot (4.5') wide decomposed granite pathway for pedestrian use adjacent to TTM 36647. A six by twelve inch concrete mow curb (6"x12") will separate the trail from the adjacent channel slope. The mow curb will be notched every 10 feet for drainage and will be set two inches above the slope grade and one inch above the trail. Land opposite the Perris Valley Storm Channel would be landscaped to the property line or to a minimum of five feet (5') from the property line at City owned properties. Landscaping would consist of native, drought resistant vegetation along with a drip irrigation system.

The trail shall extend the entire length of the projects western boundary, from the Moreno Valley City Limit south to the east-west connection in Lot "B" of Tract 36647. The landscape plans shall include grading, fencing, plant material, irrigation, signage and appropriate pedestrian access features. The Landscape plans shall conform to the concepts, features, and standards established in the Perris Trails Master Plan, and design guidelines.

Prior to recordation of final map, the developer shall dedicate land, provide easements, or otherwise hold property in common ownership for an access point to the pedestrian bicycle trail along the Perris Valley Storm Drain on the western boundary of the project site. The access point is to occur as an east to west corridor constructed as a ten foot (10') wide asphalt concrete pathway for bicycling and a four and a half foot (4.5') wide decomposed granite pathway for pedestrian use between Lot "B;" and the proposed Detention Basin identified as Parcel "D." The access point must connect to Evans Road to allow cyclists and pedestrians access to the bicycle lanes on Evans. Prior to the issuance of building permits the applicant shall include a design detail of the pedestrian access on the proposed Landscape Plan. These facilities shall be effectively integrated

into the development through the use of fence, pavement, and plant materials used commonly throughout the development. Particular attention should be given to disabled access, privacy for adjacent 'dwellings (i.e., adequate setbacks and landscape screens), pedestrian safety, and include the installation of bollards to prevent entrance of motorized vehicles.

Wayfinding/Kiosk signage shall be provided at various locations as specified in these conditions. Wayfinding/Kiosk signage shall be provided at the trail connection access point, between Lot "B;" and the proposed Detention Basin identified as Parcel "D." Such signage and the location of the signage shall be consistent with approved signage for the Perris Valley Trail and must be approved by the Community Services Department prior to installation.

Prior to the issuance of a certificate of occupancy for the 45th unit in the tract, the developer shall complete all actions required to complete annexation of the project into any assessment, community facilities, or similar district that provides funding for maintenance, services, or public improvements that benefit the pedestrian trail. The costs and benefits shall be described in the applicable district and annexation documents.

EXHIBIT B
Aerial Map

AERIAL MAP

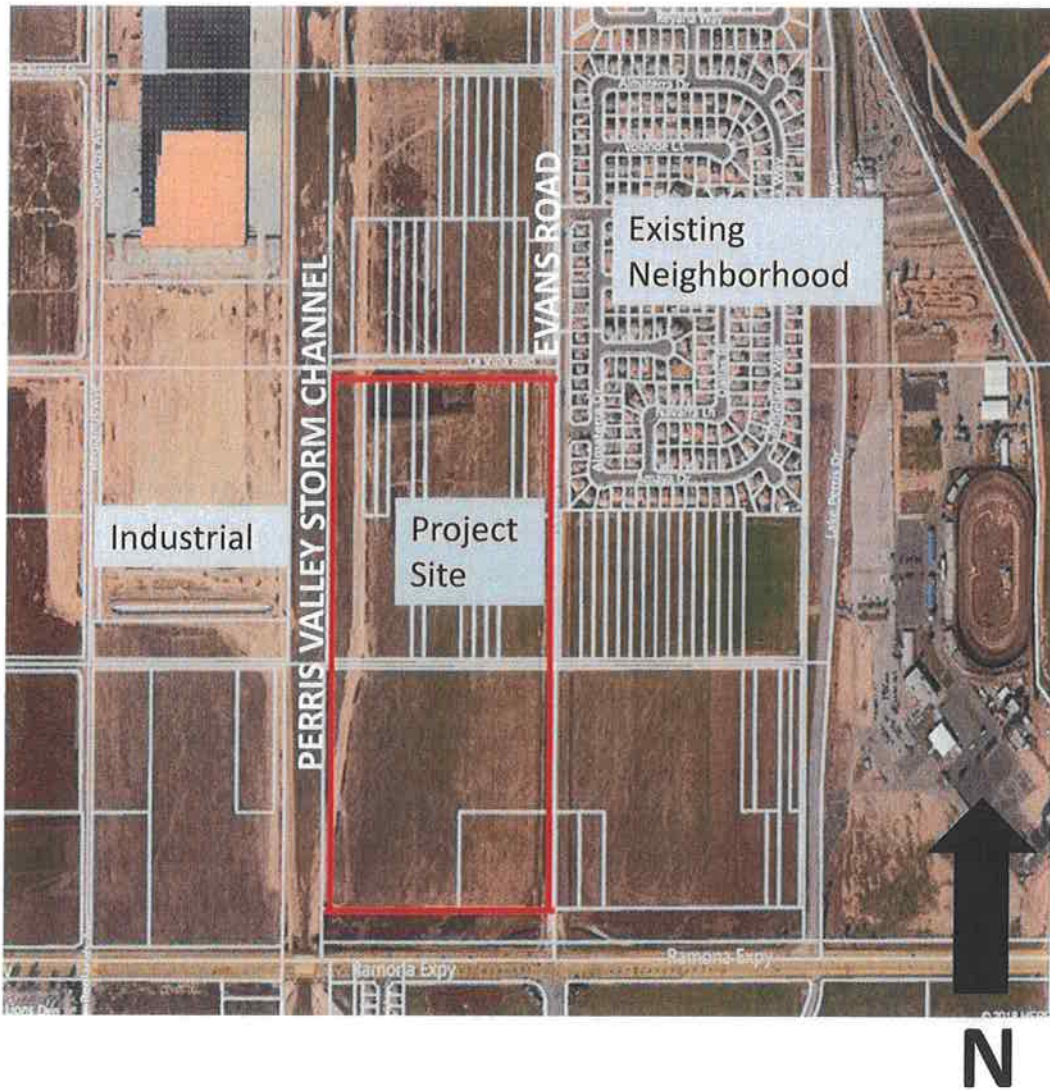

EXHIBIT C
Vicinity Map

VICINITY MAP

Tentative Parcel Map 36674

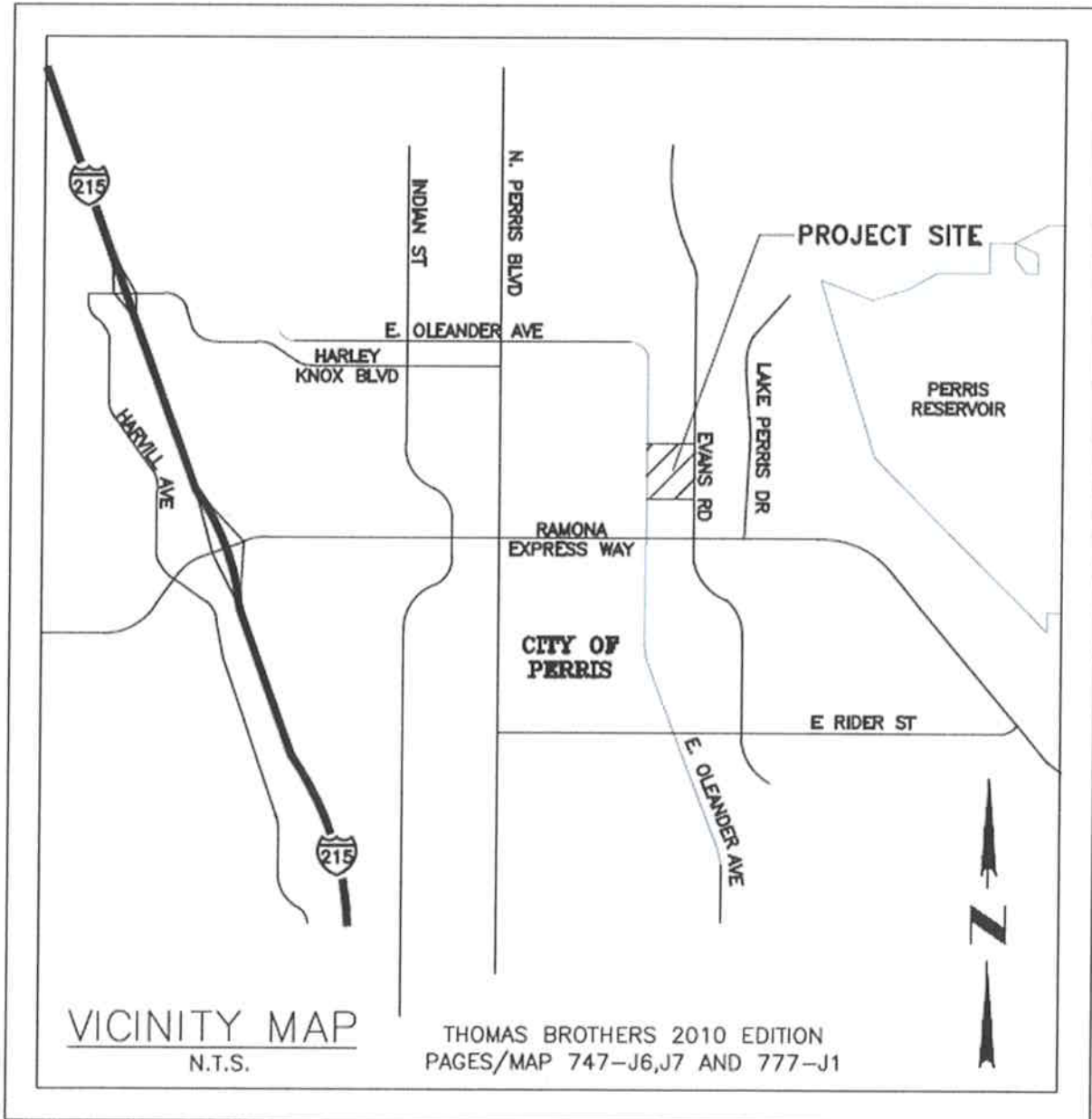

EXHIBIT D
Zone Change Exhibit

SCALE 1" = 700'







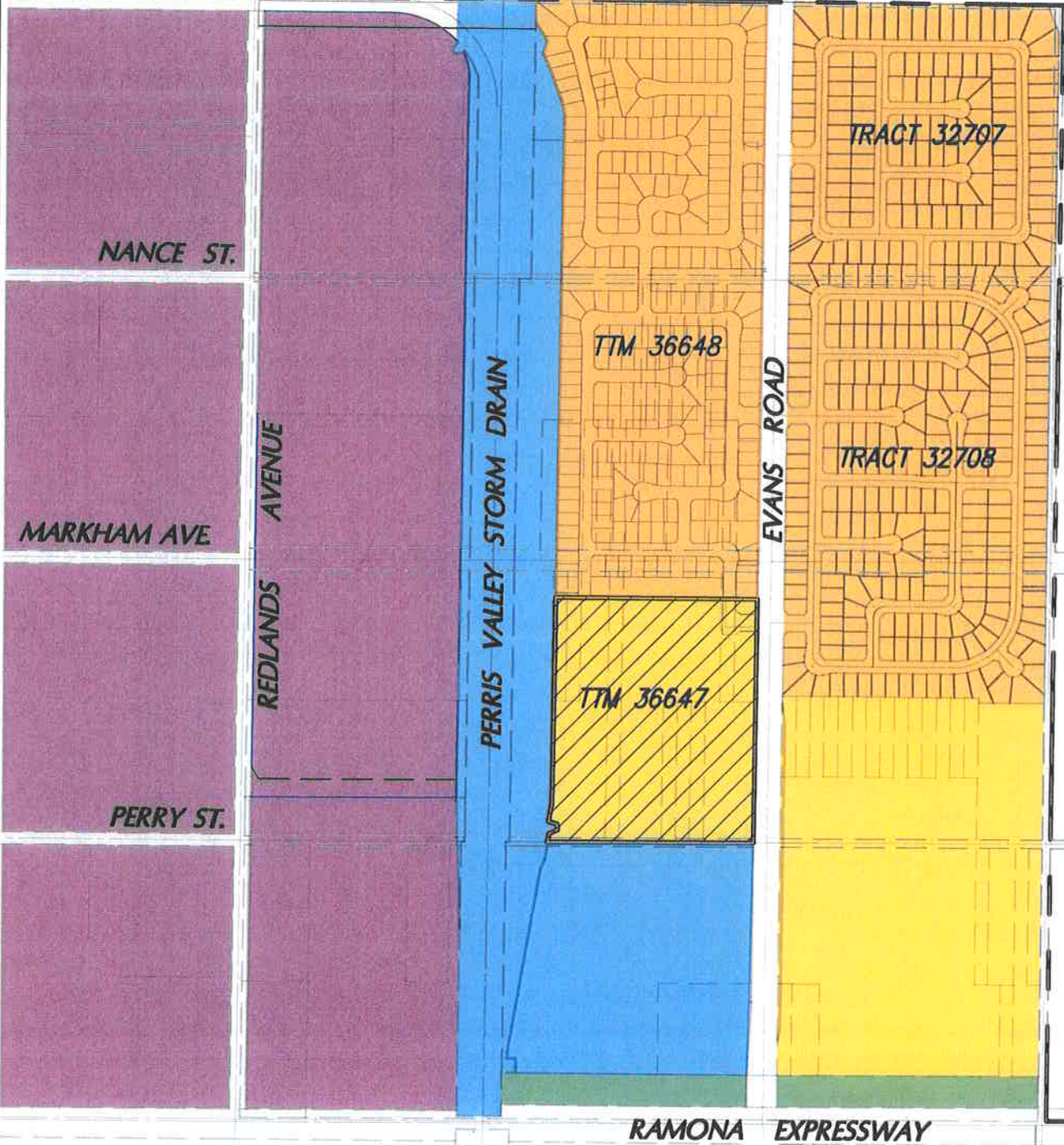

ZONE CHANGE EXHIBIT ZC 16-05218

CITY OF MORENO VALLEY



EXISTING ZONING

- | | |
|--|---|
|  R-6,000 |  NC-NEIGHBORHOOD COMM. |
|  R-10,000 |  PUBLIC |
|  PVCC SPECIFIC PLAN |  OPEN SPACE |

PROPOSED ZONING

- | |
|--|
|  R-6000 |
|--|

Exhibit D - Zone Change

EXHIBIT E
GPA Exhibit

SCALE 1" = 700'



GENERAL PLAN AMENDMENT EXHIBIT GPA 16-05217

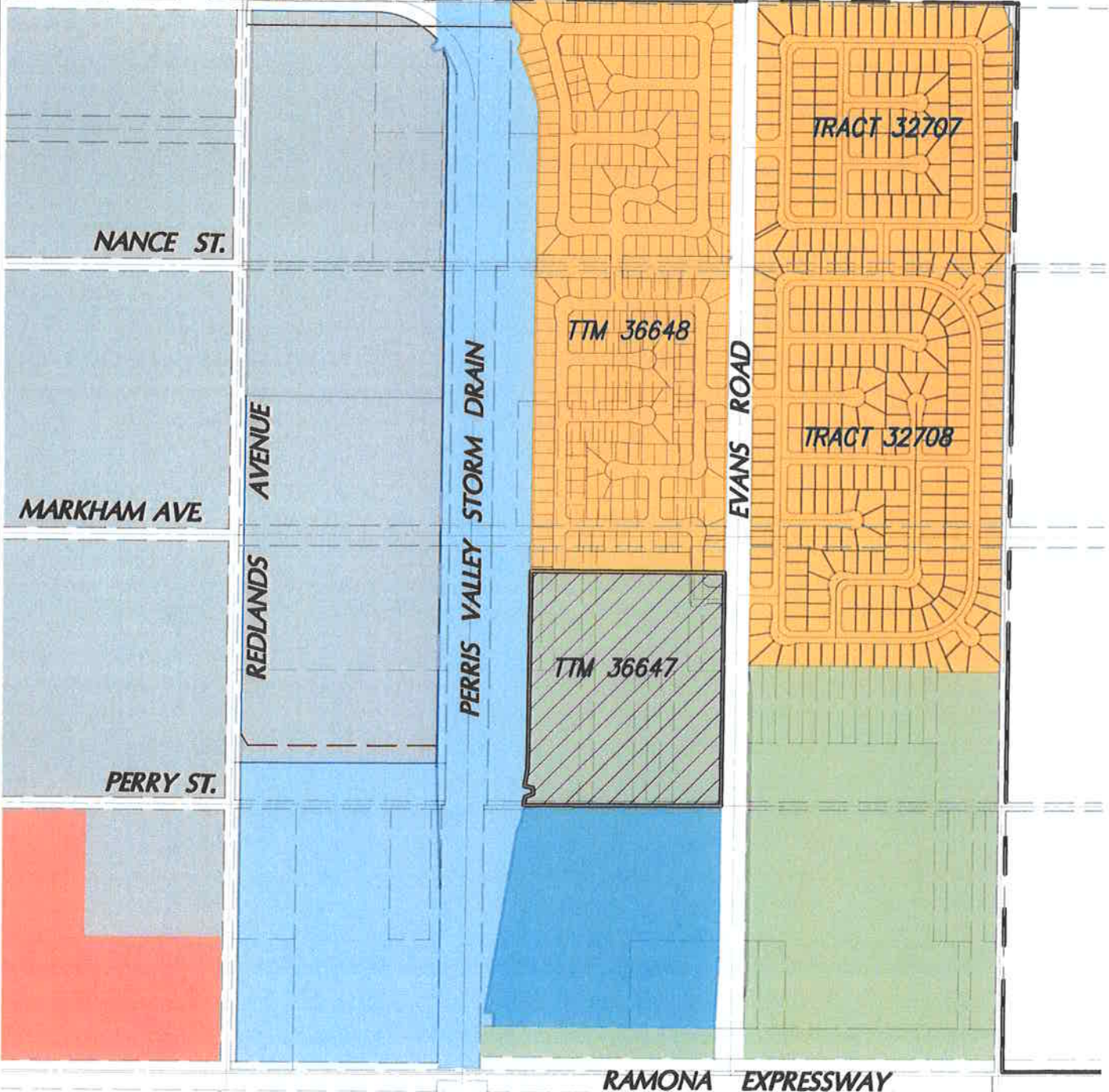

CITY OF MORENO VALLEY



EXISTING GENERAL PLAN

-  R-6000
-  SPECIFIC PLAN
-  PUBLIC

LAND USE PER PVCC SPECIFIC PLAN

-  LIGHT INDUSTRIAL
-  PVSD CHANNEL
-  COMMERCIAL

PROPOSED LAND USE

-  R-6000

Exhibit E - GPA

EXHIBIT F

Evans Road Memo and Exhibit



Memorandum

To: Habib Motlagh, City of Perris
Nathan Perez, City of Perris

From: Dilesh Sheth, P.E., T.E. *Dilesh Sheth*

Date: March 22, 2016

Re: TTM36647 and TTM36648 Safety and Roadway Improvements along Evans Road



The purpose of this memo is to provide recommendations for roadway and safety improvements for Evans Road for Stratford Ranch Residential (TTM36647 and TTM36648). Phase 1 of development of Stratford Ranch is the proposed TTM36648. Phase 2 is TTM36647. The recommendations are based on the Traffic Impact Analysis conducted for TTM36647 and TTM36648 along with an analysis of the current safety conditions of Evans Road, particularly in regards to pedestrians.

Existing Conditions

Evans Road

Currently, Evans Road is a 2 to 3 lane in each direction primary arterial with a 14' raised median. It connects north with Lasselle Street in the City of Moreno Valley, a 2 lane in each direction arterial with an 18' raised median. According to the Stratford Ranch (TTM36648) Traffic Impact Analysis, Evans Road, near the location of Rancho Verde High School, currently carries approximately on average 21,000 vehicles daily. The current speed limit is 55 MPH on Evans Road in the City of Perris between Ramona Expressway and the City limit and 50 MPH north of Rancho Verde High School in the City of Moreno Valley. The City of Perris has adopted a master bike plan for the City of Perris, which includes implementing bike lanes along Evans Road. The City of Moreno Valley has designated between the City limit and Via De Anza as a bike route. There are currently no bike lanes along Evans Road between Ramona Expressway and Via De Anza. The primary land use or zoned land use along Evans Road is residential, except at the intersection with Ramona Expressway, where there is a future commercial development planned.

Rancho Verde High School & Pedestrians

RK Engineering performed the Rancho Verde High School Traffic/Circulation Review in October 2009. The school was originally designed for a student population of approximately 2,400 students but in 2009, the student population was approximately 3,300 students with a staff of approximately 250 employees. The school built new facilities to accommodate students but the amount of parking has only decreased over the years. The review pointed to the inadequacy of the on-site circulation with only one fully functioning access point from Lasselle Street. The review also observes mid-block "jaywalking" as a major safety concern because "parents park on the west side of Lasselle Street in a southbound direction."

PM counts, 25 pedestrians were observed jumping the fence at the school's southern driveway and 74 pedestrians were observed jaywalking just south of where the fence ends at Camino Delrey. Attached to this memo are the counts collected.

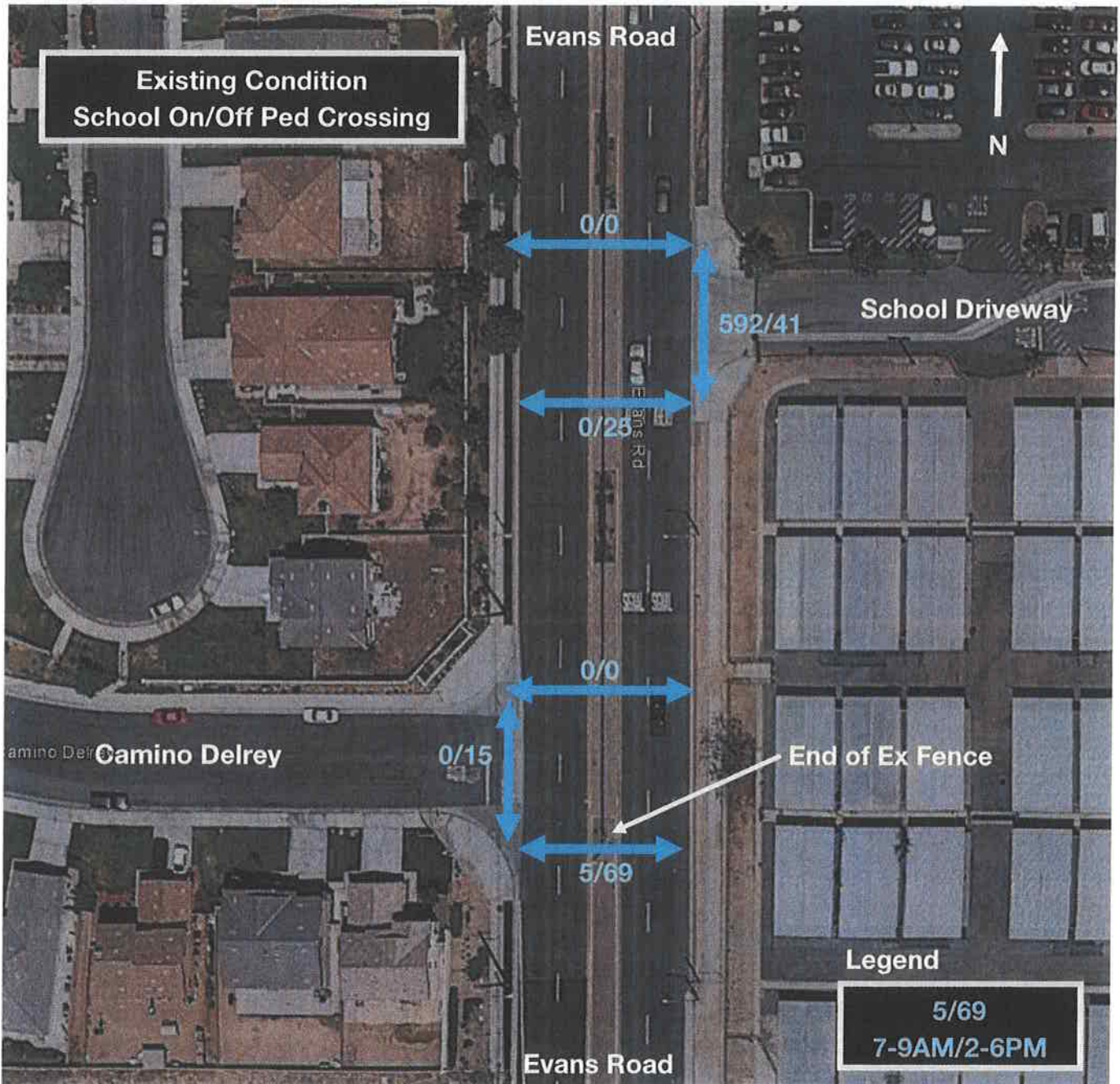

Figure 1: Existing Pedestrian Counts during School On & Off periods at Camino Delrey and School Driveway

Project and Future Conditions

With the addition of the proposed Stratford Ranch (TTM36648) and other cumulative projects in the area, Evans Road is predicted to operate on average 26,500 vehicles a day.

The Stratford Ranch residential project proposes providing the existing ultimate right-of-way for Evans Road as designated in the General Plan and providing 2 through lanes in each direction, bike lanes, and a right turn lane. The right turn lane is proposed to be designed so that in the future, the City can decide if necessary to restripe the right turn lane into a through lane and would not have to perform any additional street improvements. This is in contrast with the City's request for 3 through lanes in the southbound direction, bikes lanes and a right turn lane.

Pedestrian Safety

Collisions with Pedestrians

According to the Federal Analysis Reporting System, a data resource website for the National Highway Traffic Safety Administration, 69% of pedestrian fatalities are at non-intersection locations. These are the locations where pedestrians are not expected and cars travelling at full speed can cause fatalities.¹

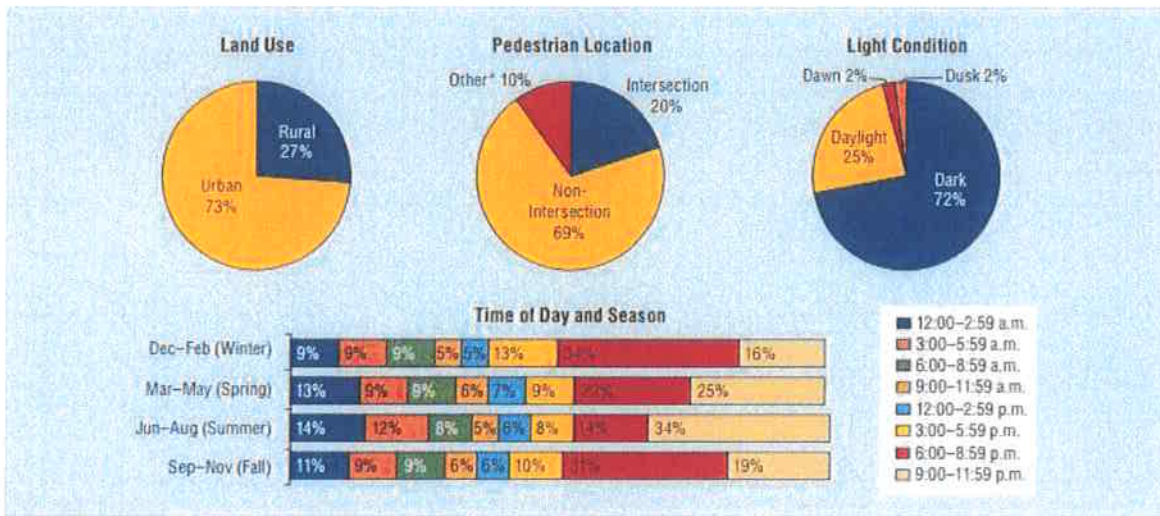

Source: FARS 2013 ARF.
 Note: Unknown values were removed before calculating percentages.
 * Other includes parking lane/zone, bicycle lane, shoulder/roadside, sidewalk, median/crossing island, driveway access, shared-use path/trail, non-trafficway area, and other.

Figure 2: Percentage of Pedestrian Fatalities in Relation to Land Use, Pedestrian Location, Light Condition, and Time of Day and Season. Source FARS 2013.

There's a high correlation with pedestrian fatalities and the speed of the motor vehicle. Figure 3 from the Traffic Advisory Unit analyzes the probability for fatal, injury-causing, or with no injury accidents, dependant on vehicle speed. The probability for fatality dramatically decreases from approximately 85% with 40 MPH to approximately 5% with 20 MPH. In San Francisco, between 2005 and 2011, 90% of pedestrian fatal collisions were with vehicles traveling at 55 MPH.²

¹ National Highway Traffic Safety Administration. FARS 2013 ARF Pedestrian Collisions Data.

² San Francisco Planning Department. "WalkFirst: Making San Francisco safer one step at a time." Accessed March 27, 2015. <<http://walkfirst.sfplanning.org/index.php/>>

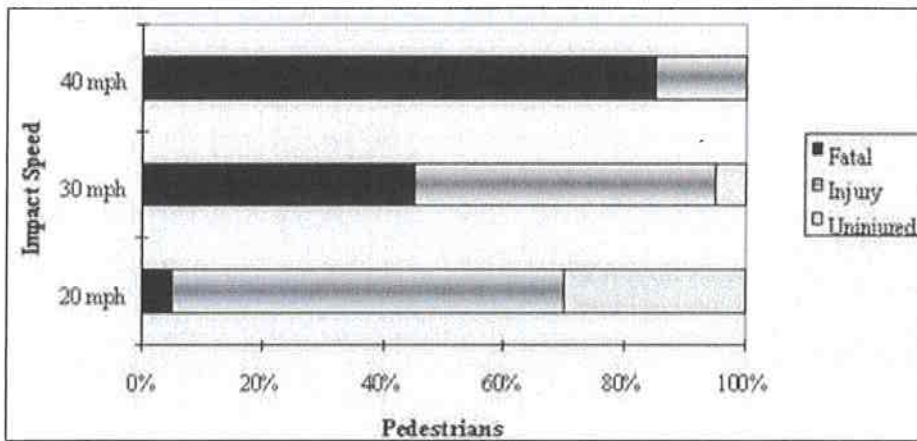

Figure 3: Pedestrian Injury Severity Based on Vehicle Speed. Source: Traffic Advisory Unit, 1993.

Figure 4 from the Transportation Authority of Marin and republished by Safe Routes to School, shows the increasing distance of number of feet motorists will need in order to stop a car. As the speed increases, the distance needed increases.³

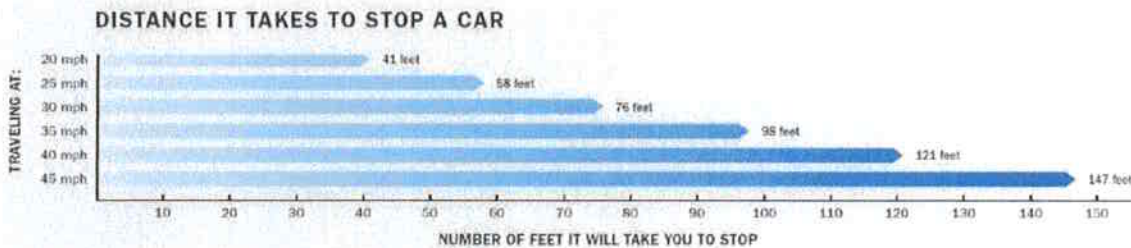

Figure 4: Travel Speed vs. Reaction and Braking. Source: Street Smarts Marin, Transportation Authority of Marin

ITE advises that physical changes to roadways to achieve traffic calming are generally more self-enforcing than traditional education and enforcement efforts and offer long-term benefits and do not require continued intervention. Physical changes to roadways suggested include curb extensions, chicanes, lateral shifts, and chokers, speed humps, speed tables and raised crosswalks, raised intersections, neighborhood traffic circles/mini-traffic circles, half-street closures, median islands, and forced-turn islands. In particular with curb extensions, the publication cites reducing roadway width from curb to curb as one way to shorten crossing distance for pedestrian and make it easier for motorists to see pedestrians, which both improve pedestrian crossing safety.⁴

Possible Recommendations for Improving Pedestrian Safety

Proposals based on Rancho Verde High School Traffic Review

RK Engineering in the Rancho Verde High School Traffic Review made many recommendations to improve the on-site and off-site circulation. On and off-site circulation improvements would improve pedestrian safety

³ Institute of Transportation Engineers. "Safe Routes to School Briefing Sheets: The Use of Traffic Calming Near Schools."

⁴ Institute of Transportation Engineers. "Safe Routes to School Briefing Sheets: The Use of Traffic Calming Near Schools."

for Evans Road. On-site improvements would encourage parents to turn into the school and use the on-site drop off locations instead of choosing to drop kids off on the street. One such recommendation is the connection with Lake Perris Drive to encourage use of the secondary right-in-right-out driveway south of the main driveway.

An off-site recommendation made for Evans Road is to extend the existing median fence south of the existing fence as far as possible to prohibit pedestrians from crossing Lasselle Street.⁵ The fence currently ends just south of the Camino Del Rey intersection with Evans, by the border of the City of Perris and the City of Moreno Valley. Pedestrian counts at the Camino Del Rey intersection show 69 people crossing at that location during the afternoon hours.

Proposal based on TTM36648

Based on the above review of pedestrian safety, three lanes would be safer for pedestrians than four lanes. In addition, the California Manual on Uniform Traffic Control Devices (MUTCD) has designated the pedestrian walking speed to be 3.5 feet per second. Therefore on a 94' wide roadway (as proposed by TTM36648), pedestrians would take 27 seconds to cross the road. Adding an additional lane, as proposed by the City, would require an 106' wide roadway and 30 seconds to cross the road.

If lanes were reduced to be 11' through lanes, motorists are likely to drive slower and there would be space for other potential pedestrian or bicycle improvements. Furthermore, according to the FHWA, a reduction in vehicle interactions resulting from a road diet can decrease the number and severity of crashes.⁶ According to San Francisco's WalkFirst program, a program that seeks to reduce serious and fatal injuries in San Francisco, lists road diets as one of their safety tools to encourage drivers to reduce vehicle speeds. Road diets eliminate a lane or more of travel.⁷

Figure 5: Median Island Pedestrian Refuge Crossing. Source: FHWA



Proposals based on Literature Review

Median Islands – Median Refuge

Median islands can be used as a median refuge for pedestrians crossing wide roads. "The Federal Highway Administration (FHWA) strongly encourages the use of raised medians (or refuge areas) in curbed sections of multi-lane roadways in urban and suburban areas, particularly in areas where there are mixtures of a significant number of pedestrians, high volumes of traffic (more than 12,000) vehicles per day) and intermediate or high travel speeds."⁸

⁵ RK Engineering. "Rancho Verde High School Traffic Review." October 7, 2009.

⁶ FHWA. "Public Roads: Going on a Road Diet." Accessed March 26, 2015.

www.fhwa.dot.gov/publications/publicroads/11septoct/05.cfm

⁷ San Francisco Planning Department. "WalkFirst: Making San Francisco safer one step at a time." Accessed March 27, 2015.

<http://walkfirst.sfplanning.org/index.php/>

⁸ FHWA. "Safety Benefits of Raised Medians and Pedestrian Refuge Areas." February 2013.

Mid-block Crossing

According to the NACTO Urban Street Design Guide, “midblock crosswalks facilitate crossings to places that people want to go but that are not well served by the existing traffic network. These pedestrian crossings, which commonly occur at schools, parks, museums, waterfronts and other destinations, have historically been overlooked or difficult to access, creating unsafe or unpredictable situations for both pedestrians and vehicles.”⁹ A mid-block crossing has the potential of addressing the pedestrian crossing demand and focusing them at a central location. They are incentivized to cross at this location because pedestrians feel safer in a marked crosswalk. Mid-block crossings should be designed with some of the following proposals to improve the safety.

Curb Extension

A curb extension can also be coupled with a crosswalk to reduce the pedestrian crossing distance, increase pedestrian and driver visibility. The longer the pedestrian crossing distance, the longer pedestrians are in the street, the longer the delay on vehicular traffic and the greater the probability for accidents.

Figure 6: Midblock crossing curb extensions provide better visibility for motorists and pedestrians. Source: FHWA

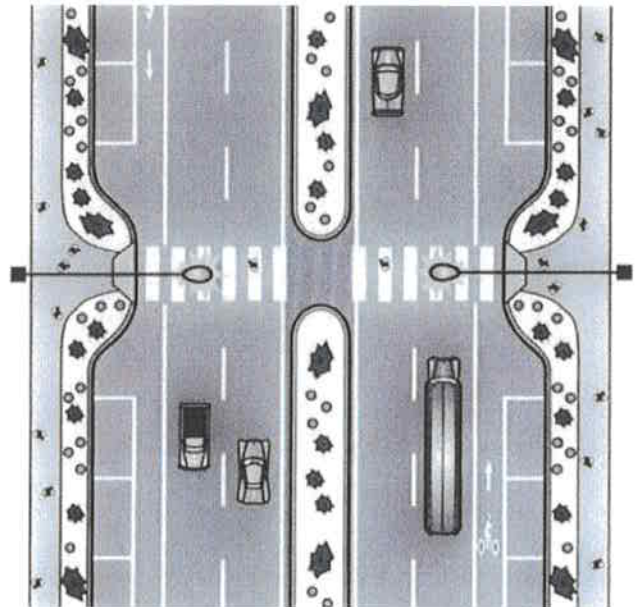

Pedestrian Beacon/Signals

A pedestrian crossing without a traffic signal can also be signaled with flashing beacons, a hybrid beacon, a conventional traffic signal and/or a pedestrian actuated signal device with a locator tone for pedestrians with vision impairments.¹⁰ According to the FHWA, the installation of pedestrian hybrid beacons reduced pedestrian crashes by 69 percent. Their study suggests a 19 percent reduction in total crashes and severe crashes was reduced by 15 percent.¹¹

Raised Crosswalk

An additional option is to vertically raise the crosswalk. The raised crosswalk would provide level street crossing and also make pedestrians more visible to approaching motorists. For vehicles the raised crosswalk would also operate as a speed table to slow drivers down for the 25 MPH reduce speed limit zone. According to Fehr & Peers, speed tables on average see a 45% decrease in accidents.¹² The raised crosswalk would be coupled with signs to warn drivers.

High-Visibility Crosswalks

The visibility of crosswalks can be enhanced through striping. Figure 5 shows various crosswalk treatments including the high-visibility crosswalk treatments. Crosswalk treatments are inexpensive and provide a better

⁹ NACTO. “Urban Street Design Guide.” Accessed March 26, 2015. <nacto.org>

¹⁰ FHWA. “Designing Sidewalks and Trails for Access: Best Practices Design Guide.” Accessed March 26, 2015. <www.fhwa.dot.gov/environment/bicycle_pedestrian/publications/sidewalk2/sidewalks208.cfm>

¹¹ FHWA. “Pedestrian Hybrid Beacon Guide – Recommendations and Case Study.” March 2014.

¹² Traffic Calming.org. Accessed March 26, 2015. <trafficcalming.org>

visual queue of where pedestrians could be crossing. The continental crosswalk can be designed to avoid wheel paths and reduce long-term maintenance needs.¹³

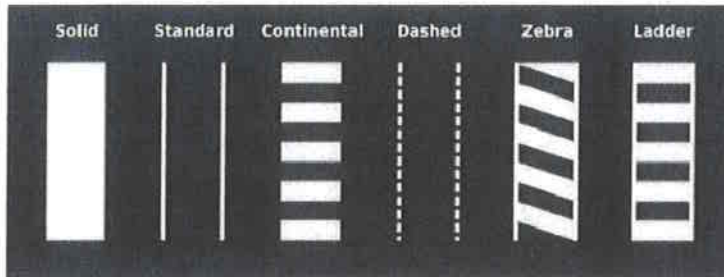

Figure 7: High-Visibility Crosswalk Treatments. Source: SFbetterstreets.org

Pedestrian Lighting

Lighting for crosswalks and for pedestrian walkways improve the safety and security for both traffic and for pedestrians crossing sidewalks. According to FARS 2013, 72% of collisions happen at night.¹⁴ Therefore lighting crosswalks and mid-block crosswalks can greatly reduce the probability of collisions.

Reduced Speed Limit Zone

Currently the speed limit zone starts at the City of Moreno Valley and City of Perris limit, but according to the suggested distance from the California MUTCD and ITE and SRTS Publication on Reduced School Area Speed Limits, the suggestion is 200 feet in advance of the school grounds.¹⁵

| School Speed Limit (mph) | Distance to Crosswalk or First Driveway (ft.) |
|--------------------------|---|
| 20 | 200 |
| 25 | 200 |
| 30 | 300 |
| 35 | 400 |

Figure 8: Suggested beginning of school speed limit zone. Source: Institute of Transportation Engineers (ITE)

Application

Improvements by Rancho Verde High School

This memo recommends that Rancho Verde High School implements the recommendations made by RK Engineering for improving school on-site circulation. Without improvements by the school, the current unsafe travel patterns are only going to continue or can grow worse. On-site circulation can be improved for example through a direct connection to Lake Perris Drive, as mentioned in the memo made by RK Engineering.

Improvements by TTM36648

The following is a summary of the possible improvements listed above that have direct application and are recommended for improving pedestrian safety along Evans Road in connection with the Rancho Verde High School. Other improvements listed here that are not mentioned above are roadway improvements tied to the forecasted traffic from the development. Refer to the attached Evans Road exhibit for details.

¹³ SFBetterStreets.org. "A guide to making street improvements in San Francisco." Accessed March 27, 2015. <www.sfbetterstreets.org/>

¹⁴ National Highway Traffic Safety Administration. FARS 2013 ARF Pedestrian Collisions Data.

¹⁵ Institute of Transportation Engineers. "Safe Routes to School Briefing Sheets: The Use of Traffic Calming Near Schools."

1. Install a traffic signal at the intersection of Belserra Gate and Evans Road with appropriate striping as early as possible, before TTM36648, to facilitate safe crossing at this location.
2. Extend the median fence to Belserra Gate to discourage pedestrians from crossing at non-crosswalk marked locations and cross instead at the signal to be installed.
3. Maintain Evans Road as 2 through lanes in each direction in front of the residential tracts per TTM36648's recommendations.
4. Reduce lane widths to 11' to reduce motorists' speed and allocate additional street space for bike lanes and an expanded bike lane buffer. Refer to the attached Evans Road exhibit for details.
5. A new crosswalk at the EMWD easement's future trail crossing, south of the Camino Delrey intersection, with:
 - a. An opening in the pedestrian fence for this crosswalk,
 - b. Median improvements to serve as a pedestrian refuge, and
 - c. Pedestrian signal or warning beacon to warn motorists of pedestrians.
6. Continental striping at all proposed and existing school crosswalks.
7. Pedestrian lighting improvements especially at crosswalks.
8. Modify the existing Marbella Gate intersection to right-in-right-out to reduce potential conflicting turning movements along Evans Road by extending the median through the intersection.
9. Extend school area reduced speed limit zones south into the City of Perris per the California MUTCD.
10. Interconnect traffic signals on Evans Road from Ramona Expressway to Via de Anza and synchronize the signals at 45 MPH.
11. Update the traffic signal at Anira Court and Evans Road to accommodate shifted lanes and bike lanes. The traffic signal at Ramona Expressway would also need to be updated along with the installation of a southbound overlapping right turn signal per the traffic impact analysis for TTM 36648.
12. Reconfigure Evans Road median to create left turn pockets as shown in the Evans Road exhibit attached.
13. Pay cash-in-lieu fair share for cumulative improvements as identified in the traffic impact analysis for TTM36647.

A second phase of improvements associated with the **TTM36647** (just south of TTM36648) are listed below.

1. Widen Evans Road to the ultimate cross section from the southerly line of Tract 32708 to the northerly DWR easement line. This improvement will require the relocation of 6 existing SCE power poles. Refer to the Evans Road exhibit for geometrics.
2. Restripe Evans Road from the southerly line of Tract 32708 to Ramona Expressway with bike lanes, buffer and reduced lane widths. Refer to the attached Evans Road exhibit for details.

3. Update traffic signal at Ramona Expressway and Evans Road as necessary to accommodate shifted lanes and bike lanes.
4. Construct full width median along Evans Road.
5. Pay cash-in-lieu fair share for cumulative improvements as identified in the traffic impact analysis for TTM36647.

Improvements by City of Perris and City of Moreno Valley

1. Implement no parking signs except residents in adjacent residential tracts.
2. To encourage safe behavior and discourage dangerous behavior for motorists and for pedestrians, increased police enforcement may be necessary. Police enforcement should enforce the following:
 - a. Pedestrians jaywalking across Evans. Guide them to the new and improved crosswalks,
 - b. Vehicles stopping along Evans Road, and
 - c. Speeding particularly within 200 feet of the school grounds during school hours.

Citation

1. Dan Burden and Peter Lagerwey, "*Road Diets: Fixing the Big Roads*," (Walkable Communities, Inc., 1999).
2. Erik Rosen and Ulrich Sander, "*Pedestrian Fatality Risk as a Function of Car Impact Speed*."
3. Fatality Analysis Reporting System (FARS) Encyclopedia, 2013.
4. FHWA. "Evaluation of Lane Reduction 'Road Diet' Measures and Their Effects on Crashes and Injuries" (Highway Safety Information System, 2010).
5. FHWA. "Designing Sidewalks and Trails for Access: Best Practices Design Guide." Accessed March 26, 2015.
<www.fhwa.dot.gov/environment/bicycle_pedestrian/publications/sidewalk2/sidewalks208.cfm>
6. FHWA. "Public Roads: Going on a Road Diet." Accessed March 26, 2015.
<www.fhwa.dot.gov/publications/publicroads/11septoct/05.cfm>
7. Institute of Transportation Engineers. "Safe Routes to School Briefing Sheets: The Use of Traffic Calming Near Schools."
8. NACTO. "Urban Street Design Guide." Accessed March 26, 2015. <nacto.org>
9. RK Engineering. "Rancho Verde High School Traffic Review." October 7, 2009.
10. Traffic Calming.org. Accessed March 26, 2015. <trafficcalming.org>

Appendix

1. Evans Road Intersection Exhibit
2. Counts from Counts Unlimited performed in May 2014

EXHIBIT G

Perris Valley Storm Trail Cross Section

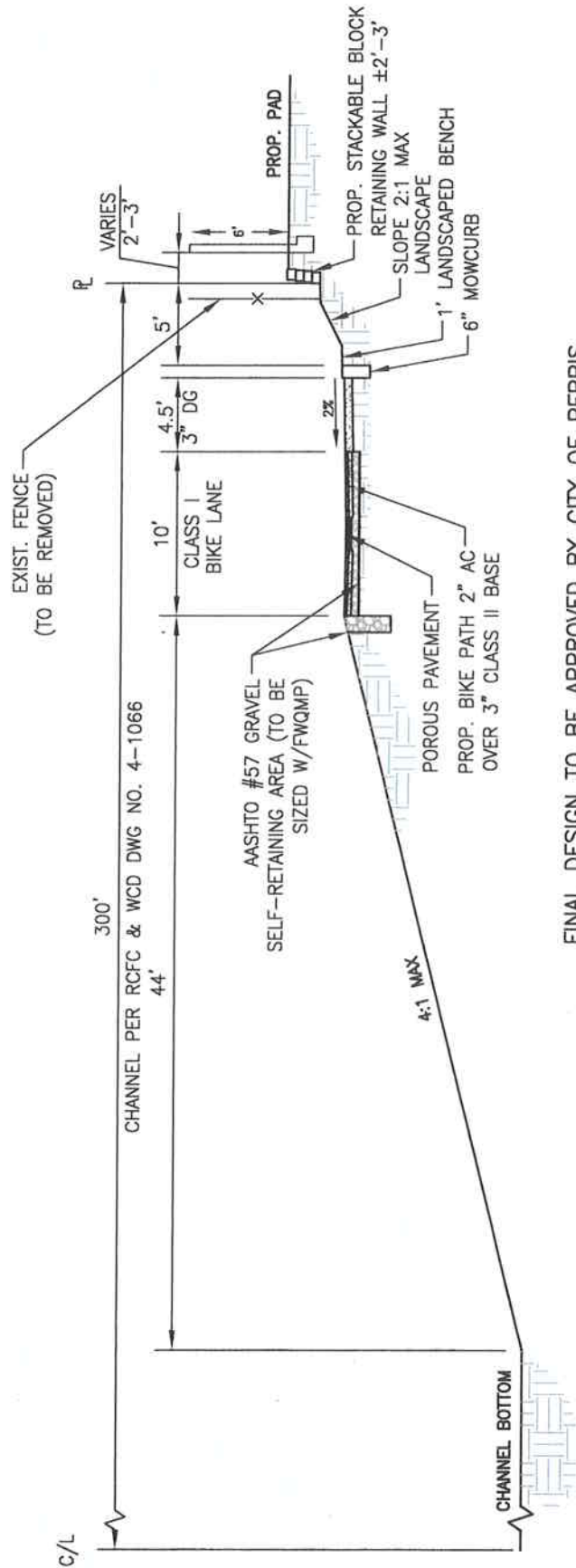

FINAL DESIGN TO BE APPROVED BY CITY OF PERRIS
 AND RIVERSIDE COUNTY FLOOD CONTROL
PERRIS VALLEY STORM DRAIN CHANNEL TRAIL
 NTS

| | | | |
|--|--|----------------|--|
| ENGINEERING CONSULTANTS 3788 MCCRAY STREET RIVERSIDE CA, 92506 PH. (951) 686-1070 FAX (951) 788-1256 | | W.O. 13-0159 | |
| WEBB | | SHEET 1 | |
| ALBERT A. ASSOCIATES | | OF 1 SHEETS | |

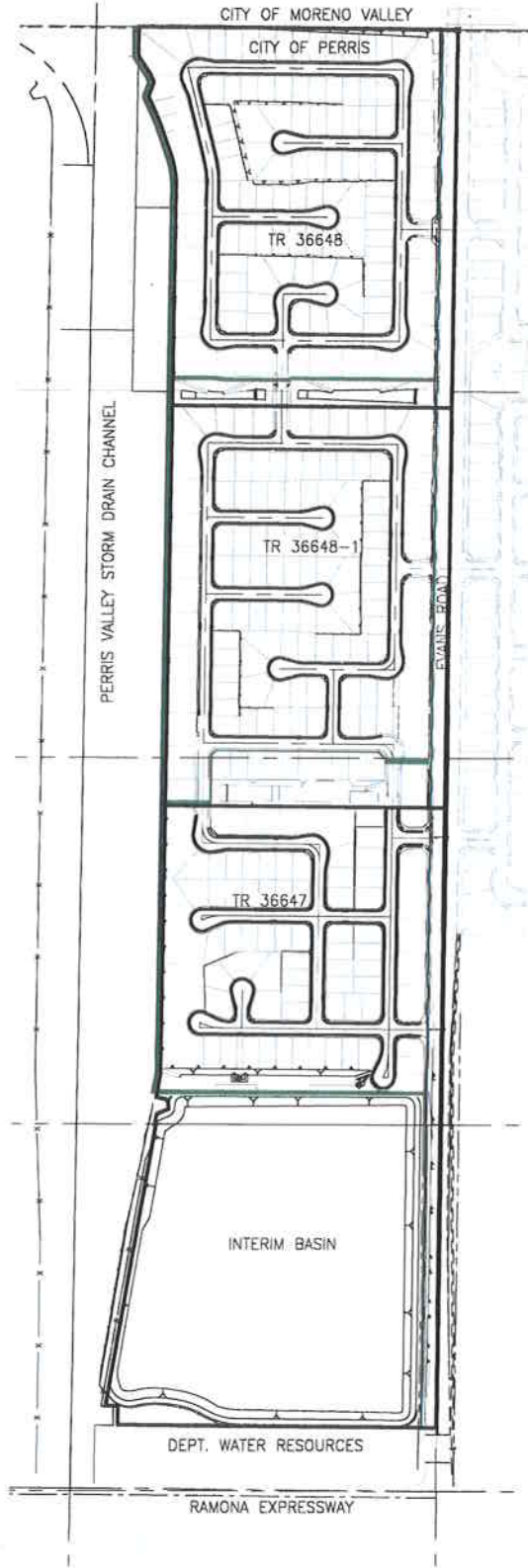

LEGEND:
 TRAILS (TR 36647 & 36648)

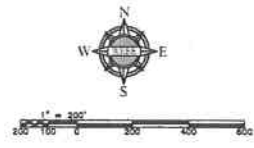

TRACTS 36647 & 36648
 TRAIL EXHIBIT

Exhibit G - Trail

0158\james\Drawings\12-0158 TRAILS Exhibit G 8/29/2016 1:12:34 PM

EXHIBIT H
PC Resolution 20-09

RESOLUTION NUMBER NO. 20-09

A RESOLUTION OF THE PLANNING COMMISSION OF THE CITY OF PERRIS, COUNTY OF RIVERSIDE, STATE OF CALIFORNIA, RECOMMENDING THAT THE CITY COUNCIL ADOPT MITIGATED NEGATIVE DECLARATION 2339, AND APPROVE TENTATIVE TRACT MAP 36647 A PROPOSAL TO AMEND THE GENERAL PLAN LAND USE AND ZONING DESIGNATION OF APPROXIMATELY 24.1 ACRES LOCATED AT THE NORTHWEST CORNER OF RAMONA EXPRESSWAY AND EVANS ROAD FROM SPECIFIC PLAN (GP DESIGNATION) AND R-10,000 (ZONING DESIGNATION) TO R-6,000 TO FACILITATE A 90 SINGLE FAMILY SUBDIVISION WITH TWO (2) LETTERED LOTS (A AND B), AND A 30.7-ACRE LOT BURROW SITE, SUBJECT TO CONDITIONS OF APPROVAL AND THE FINDINGS NOTED HEREIN.

WHEREAS, the applicant, *Mission Pacific Land Company* filed Tentative Tract Map 36647 (15-05002) to subdivide 24.12 gross acres into 90 single-family lot subdivision with two (2) lettered lots (A and B), and a 30.7-acre lot burrow site located at the northwest corner of Ramona Expressway and Evans Road; and

WHEREAS, the applicant, *Mission Pacific Land Company* filed General Plan Amendment (16-05217) and Zone Change (15-05003) for a proposal to amend the General Plan Land Use and Zoning designation of approximately 24.1 acres located at the northwest corner of Ramona Expressway and Evans Road from Specific Plan (GP designation) and R-10,000 (zoning designation) to R-6,000; and

WHEREAS, this Tentative Tract Map, Zone Change, and General Plan Amendment has been duly noticed; and

WHEREAS, proposed Project is considered a “project” as defined by the California Environmental Quality Act (“CEQA”);

WHEREAS, between May 13, 2020 to June 15, 2020, the Initial Study/MND 2339 was made available for public review and comment during a state-mandated 30-day public review period (SCH # 2018101050); and

WHEREAS, August 5, 2020 Planning Commission public hearing was continued to August 19, 2020, at which time all interested persons were given full opportunity to be heard and to present evidence; and

WHEREAS, August 19, 2020 Planning Commission public hearing was continued to September 2, 2020, at which time all interested persons were given full opportunity to be heard and to present evidence; and

WHEREAS, a Planning Commission public hearing was held on September 2, 2020, at which time all interested persons were given full opportunity to be heard and to present evidence; and

WHEREAS, Section 66411 of the California Government Code (Subdivision Map Act) vests in the legislative bodies of local agencies the regulation and control of the design and improvement of subdivisions; and

WHEREAS, the project site is located within the March Air Reserve Base/Inland Port Airport Influence Area (March AIA) Zone D (Flight Corridor Buffer) and Zone E (other Airport Environs) which have no residential development restrictions, therefore project complies with both the 2014 March ARB/IP Land Use Compatibility Plan (March ALUCP); and

WHEREAS, on October 11, 2018, Riverside County Airport Land Use Commission (ALUC) determined that the proposed General Plan Amendment 16-05031, Zone Change 16-05030, Tentative Parcel Map (TPM 37181) 16-05150 applications are conditionally consistent with the 2014 March Air Reserve Base/Inland Port Airport Land Use Compatibility Plan (MARB ALUCP); and

WHEREAS, prior to taking action, the Planning Commission has heard, been presented with, and/or reviewed all of the information and data which constitutes the administrative record for the above-mentioned approvals, including all oral and written evidence presented to the City during all Project meetings and hearings; and

WHEREAS, Chapter 19.54 of the City of Perris Municipal Code (Zoning Code, Authority and Review Procedures) authorizes the City to approve, conditionally approve, or deny requests for a General Plan Amendment, Specific Plan Amendment and Tentative Parcel Map; and

WHEREAS, all other legal prerequisites to the adoption of this Resolution have occurred.

NOW, THEREFORE, THE PLANNING COMMISSION OF THE CITY OF PERRIS does resolve as follows:

Section 1. The above recitals are all true and correct and incorporated herein by reference.

Section 2. The Planning Commission hereby determines pursuant to Section 15070 of the CEQA Guidelines that based upon on the Initial Study, staff report, supporting exhibits, and all written and oral testimony presented at the public hearing, prepared for the project in accordance with City of Perris guidelines for implementing the CEQA, all potential significant effects on the environment can be reduced to a less than significant level through mitigation measures, the design of the development, the zoning code, and standard requirements of the City, therefore a Mitigated Negative Declaration (MND) 2339 has been prepared, with findings that:

- A. No significant environmental effects would occur and there is no substantial evidence, in light of the whole record, that the project as revised may have a significant effect on the environment, and a Mitigated Negative Declaration (MND) 2339 has been prepared.
- B. The City has complied with the California Environmental Quality Act (CEQA).
- C. Determinations of the Planning Commission reflect the independent judgment of the City.

Section 3. The Planning Commission further finds, based upon Initial Study, staff report, supporting exhibits, and all written and oral testimony presented at the public hearing, with respect to the Stratford Ranch Residential South Project, the following regarding General Plan Amendment (GPA)16-05217.

- A. ***The General Plan Amendment is consistent with the General Plan Land Use Map and applicable General Plan objectives, policies, and programs.***

The proposed amendment will result in changing the General Plan land use designation from SP to R-6,000, which will create consistency with the proposed R-6,000 Zone Change 16-05218 action. The proposed amendment would also create compatibility with the existing adjacent General Plan residential land use designations on the north and east. Further, changing the General Plan land use designation from SP to R-6,000 further aligns the property and General Plan land use designation with the direction of the community, which seeks to provide additional housing options to meet unmet housing demands and logically extends the existing zoning pattern to the north and east of the site.

The proposed General Plan Amendment conforms to the goals of the General Plan as future development is conditioned to comply with zoning code development standards and provide for adequate services, infrastructure and facilities, which implements the General Plan goals, objectives and policies.

Furthermore, the General Plan Amendment #16-05217 is consistent with General Plan Policy I.A of the General Plan Land Use Element, which seeks to promote variety in dwelling types, densities and locations to satisfy changing demands as the community evolves and matures. It is also consistent with Goal 1 of the Housing Element, which seeks to promote and maintain a variety of housing types for all economic segments of the City. Finally, as conditioned, the project meets or exceeds the objectives of the proposed R-6,000 General Plan land use designation and as such, is consistent with the General Plan Land Use Map and applicable General Plan objectives, policies, and programs.

- B. ***The proposed amendment would not be detrimental to the public interest, health, safety, convenience, or welfare of the City.***

The proposed amendment will not be detrimental to the public interest, health, safety, convenience, or welfare of the City. The amendment to change the General Plan land use designation from "SP" to R-6,000 will facilitate the development of single family housing, to meet demand in the City and regional housing demand which is consistent with the General Plan goals and objectives. The site is located in an urbanizing area that

is surrounding by single family residential on the north and east with a similar residential density. Adequate site access and services are readily available and future development will be required to adhere to all applicable city codes, standards and policies, and thus the amendment would not be detrimental to the public interest, health, safety, convenience or welfare.

- C. *In the case of an amendment to the General Plan Land Use Map, the subject parcel(s) is physically suitable (including, but not limited to access, provisions of utilities, compatibility with adjoining land uses, and absence of physical constraints) for the requested land use designation(s) and the anticipated land use development(s).***

The proposed General Plan Amendment will bring the property into conformance with the proposed Zone Change, which will facilitate single family residential development in the future in a manner consistent with existing neighborhood fabric, the General Plan's vision and the City's Development Code. The parcel is physically suitable for single-family residential use, as it is of adequate shape and size and utilities and city services are readily available to service the site. The property would gain access from the adjoining a public roadway and future development would be at the same density as the adjoining residential land use to the north. The site is relatively flat and does not have any physical constraints, such as steep slopes or watercourses to prevent future single-family development.

Section 4. The Planning Commission further finds, based upon Initial Study, staff report, supporting exhibits, and all written and oral testimony presented at the public hearing, with respect to the Stratford Ranch Residential South Project, the following regarding Zone Change 16-05218:

- A. *The proposed zoning is consistent with the General Plan Land Use Map and applicable General Plan objectives, policies, and programs.***

The proposed R-6,000 zoning will create consistency with the proposed R-6,000 proposed General Plan land use designation and facilitate future single family residential development at a density of 4-7 dwelling units per acre, which is consistent with the density proposed.

As designed and conditioned the proposed Zone Change #16-05218, is consistent with the proposed General Plan Amendment # 16-0517, and the R-6,000 zoning district, with respect to minimum required development standards, including lot width, depth and size. Therefore, as designed and conditioned, the TTM 36674 is consistent with the City's General Plan Land Use Map.

The proposed Zone Change is consistent with the proposed R-6,000 General Plan Land Use Designation and Map and conforms to the goals of the General Plan by complying with the subdivision and zoning code development standards, which implements the General Plan goals, objectives and policies. Additionally, the project provides for adequate services, infrastructure and facilities for the site and mitigates potential environmental impacts.

Furthermore, the proposed Zone Change is consistent with General Plan Policy I.A of the General Plan Land Use Element to promote variety in dwelling types, densities and locations to satisfy changing demands as the community evolves and matures. The proposed Zone Change is also consistent with Goal 1 of the Housing Element, which seeks to promote and maintain a variety of housing types for all economic segments of the City. Finally, as conditioned, the project meets or exceeds the objectives of the proposed R-6,000 General Plan land use designation and as such, the proposed Zone Change is consistent with the General Plan Land Use Map and applicable General Plan objectives, policies, and programs.

B. The proposed zoning is compatible with or provides adequate buffering of adjoining uses.

The proposed zoning is compatible with adjoining uses to the north and is a logical extension of the existing approved zoning pattern, immediately north of the site (Stratford Ranch Residential North), which is zoned as R-6,000, as well as surrounding residential uses to the east that are also designated as R-6,000. Further, the proposed R-6,000 zoning would facilitate the development of single family residential housing on smaller lots, which is a needed housing option in the City, region and state. Future residential development is required to undergo further plan review to insure that the design meets required building setbacks and buffering and provides for appropriate landscaping and other improvements to ensure compatibility with adjoining residential uses to the north.

C. The proposed zoning is a logical extension of the existing zoning pattern.

The proposed zoning is a logical extension of the existing approved zoning pattern, immediately north of the site (Stratford Ranch Residential North), which is zoned as R-6,000, as well as surrounding residential uses to the east that are also designated as R-6,000. The proposed zoning would also facilitate the development of more affordable, smaller lot residential housing to address an unmet market demand in the City. Future development is required to be designed in conformance with the R-6,000 zoning district, and the City's Zoning Code and applicable standards, codes and policies.

Section 5. The Planning Commission further finds, based upon Initial Study, staff report, supporting exhibits, and all written and oral testimony presented at the public hearing, with respect to the Stratford Ranch Residential South Project, the following regarding Tentative Tract Map 36647 (PLN16-05216).

A. The proposed Tentative Tract Map will not result in a significant adverse effect on the environment:

The proposed Tentative Tract Map will not result in a significant adverse effect on the environment. An Initial Study was prepared for the project, which was supported by numerous technical studies, including biological, cultural, paleontological, air quality, greenhouse gas, traffic and other studies covering the site. Because the surrounding area has been transition to an urban environment, potential adverse effects on the environment were found to be less than significant through the application of conditions of approval, mitigation measures, and design modifications.

Adequate public services and facilities are available to serve the project and potential impacts to parks and recreation and infrastructure are mitigated to an insignificant level through the requirement for on and off-site impacts, fair share payments and participation in the City's impact fee programs. Furthermore, the application of the City's standard project conditions (i.e. Erosion Control Best Management Practices, Storm Water Best Management Practices, etc.) will prevent the project from creating significant impacts to the environment.

B. As conditioned, the design of the Tract is consistent with the General Plan and the Zoning Ordinance standards for the R-6,000 zone.

The design and improvements required for TPM 36647 are consistent with the City General Plan and R-6,000 zoning, with respect to minimum required development standards, including lot width, depth and size. The lots created by TPM 36674 will provide an adequate building site, appropriate vehicular access, and recreational opportunities at a density that is compatible with existing surrounding residential uses. Further, necessary water and sewer services are available to serve the site and the development is required through conditions and approval and mitigation measures to pay its fair share and construct transportation, drainage and other improvements to serve the site. Therefore, the TTM 36674 is consistent with the City's General Plan and Zoning Ordinance.

C. The project site is physically suitable for type and density of the proposed residential development.

The site for TTM 36647 is physically suited to create a subdivision for future development for single-family residential development. The lots created by proposed project proposed are consistent with the development standards established for the R-6,000 zone, in terms of size, shape, width and depth and can readily accommodate future residential development. All future development is required to undergo additional administrative review to ensure that it meets all City code requirements for architecture, grading, and plotting.

Furthermore, TTM 36647 proposes 90 single family lots at a gross density of 4 dwelling units per acre, which is consistent with the density permitted by the R-6,000 zoning regulations. As such, the project site is physically suitable for the proposed density of development.

D. As conditioned, the proposed Tentative Tract Map is consistent with City standards, ordinances, and policies.

As designed and conditioned, the TTM 36647 is compatible with the surrounding land uses and R-6,000 zoning designation as it meets or exceeds the development standards outlined for the R-6,000 zoning district and applicable provisions of the City's Subdivision and Zoning Codes (Title 18 & 19). The proposed project is also consistent with applicable policies and plans related to drainage, recreation and transportation improvements.

E. The project is a subdivision for future residential development that is compatible with the surrounding land use and zoning designations.

As designed and through the application of the conditions of approval, the proposed subdivision, TTM 36647 is compatible with the design of the surrounding future and existing land uses and zoning designations. The proposed subdivision is compatible with the entitled Stratford Ranch Residential North (TM36648) project and the existing two residential neighborhoods immediately across Evans Road in density, zoning, and product type. Therefore, the proposed subdivision is compatible with surrounding land uses and zoning designations.

F. The proposed Tentative Tract Map will not have a negative effect on public health, safety, or general welfare.

The proposed Tentative Tract Map will not have a negative effect on public health, safety, or general welfare. The design of the subdivision is in conformance with the City's General Plan, Zoning Code, and Subdivision Ordinance. As conditioned, the developer is required to pay its fair share towards or construct improvements in order to comply with all applicable City ordinances, codes, and standards, which are intended to protect the public safety, health and welfare. Adequate services are available and in close proximity to serve the subdivision and no hazardous situations are created through the subdivision. As such, TTM 36647 will not have a negative effect on public health, safety or the general welfare of the City of Perris residents.

G. Tentative Tract Map is in compliance with the Subdivision Map Act.

The design of subdivision, TTM 36647, is in compliance with the Subdivision Map Act as the lots created by the subdivision are of adequate size to support future single-family residential development as intended and the proposed subdivision is consistent with the standards outlined for R-6,000 zoning district and all applicable provisions of the City's Subdivision and Zoning Codes Title 18 & 19). Therefore, TTM 36647 is in compliance with the Subdivision Map Act.

Section 6. The Planning Commission hereby recommends that the City Council adopt Mitigated Negative Declaration 2339 and Mitigation Monitoring Reporting Program (MMRP) based on the Initial Study, staff report, supporting exhibits, and all written and oral testimony presented at the public hearing,

Section 7. The Planning Commission hereby recommends that the City Council approve TTM 36647 (16-05216), Zone Change (ZC16-05218), General Plan Amendment (GPA16-05217) for the *Stratford Ranch Residential South Project*, based on the information and findings presented in the staff report and supporting exhibits, as well as all written and oral testimony presented at the public hearing, and subject to the attached Conditions of Approval.

Section 8. The Planning Commission declares that should any provision, section, paragraph, sentence, or word of this Resolution be rendered or declared invalid by any court of

competent jurisdiction, or by reason of any preemptive legislation, the remaining provisions, sections, paragraphs, sentences and words of this Resolution shall remain in full force and effect.

Section 9. The Chairperson shall sign and the Secretary shall certify to the passage and adoption of this Resolution.

ADOPTED, SIGNED and **APPROVED** this 2nd day of September, 2020.

CHAIRPERSON, PLANNING COMMISSION

ATTEST:

Secretary, Planning Commission

STATE OF CALIFORNIA)
COUNTY OF RIVERSIDE) §
CITY OF PERRIS)

I, Kenneth Phung, SECRETARY OF THE PLANNING COMMISSION OF THE CITY OF PERRIS, DO HEREBY CERTIFY that the foregoing Resolution Number 20-09 was duly adopted by the Planning Commission of the City of Perris at a regular meeting of said Planning Commission on the 2nd day of September, 2020, and that it was so adopted by the following vote:

AYES:
NOES:
ABSTAIN:
ABSENT:

Secretary, Planning Commission

Attachments: Conditions of Approval (Planning, Engineering, Public Works, Building and MMRP)

EXHIBIT I
MND/Initial Study

Mitigated Negative Declaration, Initial Study, and Associated Studies, are on File at the Planning Department and available online at:

<http://www.cityofperris.org/departments/development/planning.html>

EXHIBIT J

MMRP

MITIGATION MONITORING & REPORTING PLAN

The following environmental mitigation measures shall be incorporated into the project development as Conditions of Approval (MND 2339). The Project Applicant shall secure a signed verification for the mitigation measures to ensure compliance with Each mitigation measure, as required by the City of Perris to meet CEQA obligations and other requirements (Public Resources Code Section 21081.6.) Final clearance shall require all verifications applicable to the attached table. The Perris Development Services Department has primary responsibility for monitoring and reporting the implementation of each mitigation measure.

In response to the Notice of Preparation for a Mitigated Negative Declaration for the proposed project, the City of Perris received no comment letters in response to the distribution of the Initial Study, and therefore no changes were required.

| MITIGATION MONITORING AND REPORTING PLAN | | | | |
|--|---|---|------------------|-------------|
| TTM 36647 | | | | |
| (GPA 16-05217, ZC 16-05218, TTM 36647 and East Detention Basin Case 16-05216) | | | | |
| MITIGATION MEASURE | TIMING | VERIFICATION OF COMPLIANCE | | |
| | Prior to Building Permit Issuance | DEPARTMENT | SIGNATURE | DATE |
| BIOLOGY | | | | |
| <p>BIO-1: The following avoidance measure is recommended to prevent direct harm to burrowing owls pursuant to Objective 6 of the MSHCP burrowing owl objectives: A qualified biologist will conduct a pre-construction presence/absence survey for burrowing owls within 30 days prior to site disturbance. If burrowing owls are detected onsite, the owls will be relocated/excluded from the site outside of the breeding season following accepted protocols, and subject to the approval of the RCA and wildlife agencies.</p> | <p>Prior to site disturbance and/or issuance of any Grading Permit.</p> | <p>Planning and Building Divisions.</p> | | |
| <p>BIO-2: The following measure is recommended to avoid mortality to nesting birds. As feasible, vegetation clearing should be conducted outside of the nesting season, which is generally identified as February 1 through August 31. If avoidance of the nesting season is not feasible, then a qualified biologist shall conduct a nesting bird survey within three days prior to any disturbance of the site, including disking, demolition</p> | <p>Prior to site disturbance and/or issuance of any Grading Permit.</p> | <p>Planning and Building Divisions.</p> | | |

MITIGATION MONITORING AND REPORTING PLAN

TTM 36647

(GPA 16-05217, ZC 16-05218, TTM 36647 and East Detention Basin Case 16-05216)

| MITIGATION MEASURE | TIMING | VERIFICATION OF COMPLIANCE | | |
|---|---|--|-----------|------|
| | Prior to Building Permit Issuance | DEPARTMENT | SIGNATURE | DATE |
| <p>activities, and grading. If active nests are identified, the biologist shall establish suitable buffers around the nests, and the buffer areas shall be avoided until the nests are no longer occupied and the juvenile birds can survive independently from the nests.</p> <p>BIO-3: The Project would temporarily impact 0.03 acre of wetland Waters of the United States and 0.07 acre of CDFW jurisdiction (consisting of emergent marsh). The following mitigation measure will occur to reduce impacts to a level of less than significant:</p> <p>The Project will purchase wetland/riparian habitat establishment, re-establishment, and/or rehabilitation credits from an approved mitigation bank/in-lieu fee program at a minimum 1:1 ratio for temporary impacts. Approved mitigation banks and/or in-lieu fee programs include, but are not limited to, the Riverpark Mitigation Bank, the Inland Empire Resource Conservation District In-Lieu Fee Program, and the Riverside-Corona Resource Conservation District In-Lieu Fee Program. Mitigation for temporary impacts are proposed off site because the proposed future storm drain would remain in the PVSC for up to two years, thus impacting any on site vegetation restoration efforts.</p> <p>The Project would temporarily impact 0.07 acre of MSHCP Riparian resources (consisting of emergent marsh). The removal of 0.07 acre of MSHCP riparian resources triggers the requirement under the MSHCP that a DBESP be drafted and approved by the Wildlife Agencies. The DBESP</p> | <p>Prior to site disturbance and/or issuance of any Grading Permit.</p> | <p>Planning and Building Divisions</p> | | |

MITIGATION MONITORING AND REPORTING PLAN

TTM 36647

(GPA 16-05217, ZC 16-05218, TTM 36647 and East Detention Basin Case 16-05216)

| MITIGATION MEASURE | TIMING | VERIFICATION OF COMPLIANCE | | |
|--|-----------------------------------|----------------------------|-----------|------|
| | Prior to Building Permit Issuance | DEPARTMENT | SIGNATURE | DATE |
| <p>details the type of resource proposed for impact, why avoidance was not feasible, and the compensation provided to ensure biologically equivalent or superior preservation. The Wildlife Agencies are provided the DBESP for review by the City and they have 60 days to review the DBESP and provide comments. If no comments are provided by the Wildlife Agencies within 60 days, the DBESP is considered approved. If comments are received, the comments will be addressed until the City and the Wildlife Agencies are in agreement. The mitigation that will be presented in the DBESP will be that proposed above for CDFW riparian mitigation: purchase wetland/riparian habitat establishment, re-establishment, and/or rehabilitation credits from an approved mitigation bank/in-lieu fee program at a minimum 1:1 ratio. Approved mitigation banks and/or in-lieu fee programs include, but are not limited to, the Riverpark Mitigation Bank, the Inland Empire Resource Conservation District In-Lieu Fee Program, and the Riverside-Corona Resource Conservation District In-Lieu Fee Program.</p> <p>The riparian/riverine resources compensation can be coordinated with compensation required under Section 1602 Streambed Alteration Agreement (SAA) and CWA Sections 401 and 404 authorizations to ensure duplicate compensation does not occur.</p> | | | | |
| CULTURAL RESOURCES | | | | |
| <p>CR-1 Monitoring of earth-moving activities on a spot-check basis by a qualified archaeologist is recommended. In the event</p> | | | | |

MITIGATION MONITORING AND REPORTING PLAN

TTM 36647

(GPA 16-05217, ZC 16-05218, TTM 36647 and East Detention Basin Case 16-05216)

| MITIGATION MEASURE | TIMING | VERIFICATION OF COMPLIANCE | | |
|--|--|----------------------------|-----------|------|
| | | DEPARTMENT | SIGNATURE | DATE |
| | Prior to Building Permit Issuance | | | |
| (NAHC), which will determine and notify a Most Likely Descendant (MLD). With the permission of the landowner or his/her authorized representative, the MLD may inspect the site of the discovery. The MLD shall complete the inspection within 48 hours of notification by the NAHC. The MLD may recommend scientific removal and nondestructive analysis of human remains and items associated with Native American burials. | | | | |
| HYDROLOGY | | | | |
| MM HYD 1: Prior to the issuance of grading permits for the project site, the project applicant shall submit to the City supporting evidence of compliance with Riverside County Flood Control and Water Conservation District and the City of Perris Requirements and standards. | Prior to issuance of grading permits | Building Division | | |
| NOISE | | | | |
| NOI-1: Any equipment activity and equipment maintenance is limited to the hours between 7:00 a.m. and 7:00 p.m. Per Zoning Ordinance, Noise Control, Section 7.34.060, it is unlawful for any persons between the hours of 7:00 p.m. of any day and 7:00 a.m. of the following day, or on a legal holiday, or on Sundays to erect, construct, demolish, excavate, alter or repair any building or structure in a manner as to create disturbing excessive or offensive noise. Construction activity shall not exceed 80 dBA in residential zones in the City. | During Construction | Building Division | | |
| NOI-2: Stationary equipment that generates noise in excess of 65 dBA at the project boundaries must | | | | |

MITIGATION MONITORING AND REPORTING PLAN

TTM 36647

(GPA 16-05217, ZC 16-05218, TTM 36647 and East Detention Basin Case 16-05216)

| MITIGATION MEASURE | TIMING | VERIFICATION OF COMPLIANCE | | |
|---|--|----------------------------|------------------|-------------|
| | Prior to Building Permit Issuance | DEPARTMENT | SIGNATURE | DATE |
| <p>be shielded and located at least 100 feet from occupied residences. The equipment area with appropriate acoustic shielding shall be designated on building and grading plans. Equipment and shielding shall remain in the designated location throughout construction activities.</p> | During Construction | Building Division | | |
| TRANSPORTATION/TRAFFIC | | | | |
| On-site | | | | |
| <p>TRA-01: Construct full width street improvements on all roadways within the project to City of Perris standards.</p> | Prior to occupancy permit issuance. | Public Works | | |
| <p>TRA-02: Construct partial width improvements on the westerly side of Evans Road at its ultimate (Arterial 128 ') cross-section.</p> | Prior to occupancy permit issuance. | Public Works | | |
| <p>TRA-03: Construct the intersection of Evans Road and Marbella Gate to with the following geometrics with signalized control: Northbound: Two through lanes. One right turn lane. Southbound: Two through lanes. One right turn lane. Eastbound: One right turn lane. Stop sign controlled Westbound: One right turn lane. Stop sign controlled.</p> | Prior to occupancy permit issuance. | Public Works | | |
| <p>TRA-04: Construct the intersection of Evans Road and Project Driveway to restrict movement to right-in and right-out only from the driveway with the following geometrics: Northbound: Two through lanes. Southbound: Two through lanes. One right turn lane. Eastbound: One right turn lane. Stop controlled.</p> | Prior to occupancy permit issuance. | Public Works | | |

MITIGATION MONITORING AND REPORTING PLAN

TTM 36647

(GPA 16-05217, ZC 16-05218, TTM 36647 and East Detention Basin Case 16-05216)

| MITIGATION MEASURE | TIMING | VERIFICATION OF COMPLIANCE | | |
|---|--|---|-----------|------|
| | | DEPARTMENT | SIGNATURE | DATE |
| | Prior to Building Permit Issuance | | | |
| <p>Safety and Operational</p> <p>TRA-05: Sight distance at the project entrance roadway should be reviewed with respect to standard City of Perris sight distance standards at the time of preparation of final grading, landscape and street improvement plans.</p> <p>TRA-06: Participate in the phased construction of off-site traffic signals through payment of project's fair share of traffic signal mitigation fees.</p> <p>TRA-07: Signing/striping should be implemented in conjunction with detailed construction plans for the project site.</p> <p>Regional Funding Mechanisms</p> <p>TRA-08: The project will participate in the cost of off-site improvements through payment of the following "fair share" mitigation fees: Transportation Uniform Mitigation Fee (TUMF), current at time of construction. City of Perris Development Impact Fee (DIF), current at time of construction. These fees should be collected and utilized as needed by City of Perris to construct the improvements necessary to maintain the required level of service.</p> | <p>Prior to occupancy permit issuance.</p> <p>Prior to occupancy permit issuance.</p> <p>Prior to occupancy permit issuance.</p> <p>Prior to map recordation</p> | <p>Public Works</p> <p>Public Works</p> <p>Public Works</p> <p>Public Works</p> | | |

EXHIBIT K

TTM 36647 Exhibits

TENTATIVE TRACT MAP NO. 36647 CONCEPTUAL GRADING

PERRIS VALLEY STORM DRAIN CHANNEL
(PER APPROVED DWG NO. 4-2066)

GENERAL PLAN LAND USE: PUBLIC
ZONING: OPEN SPACE

GENERAL PLAN LAND USE: SPECIFIC PLAN
ZONING: OPEN SPACE

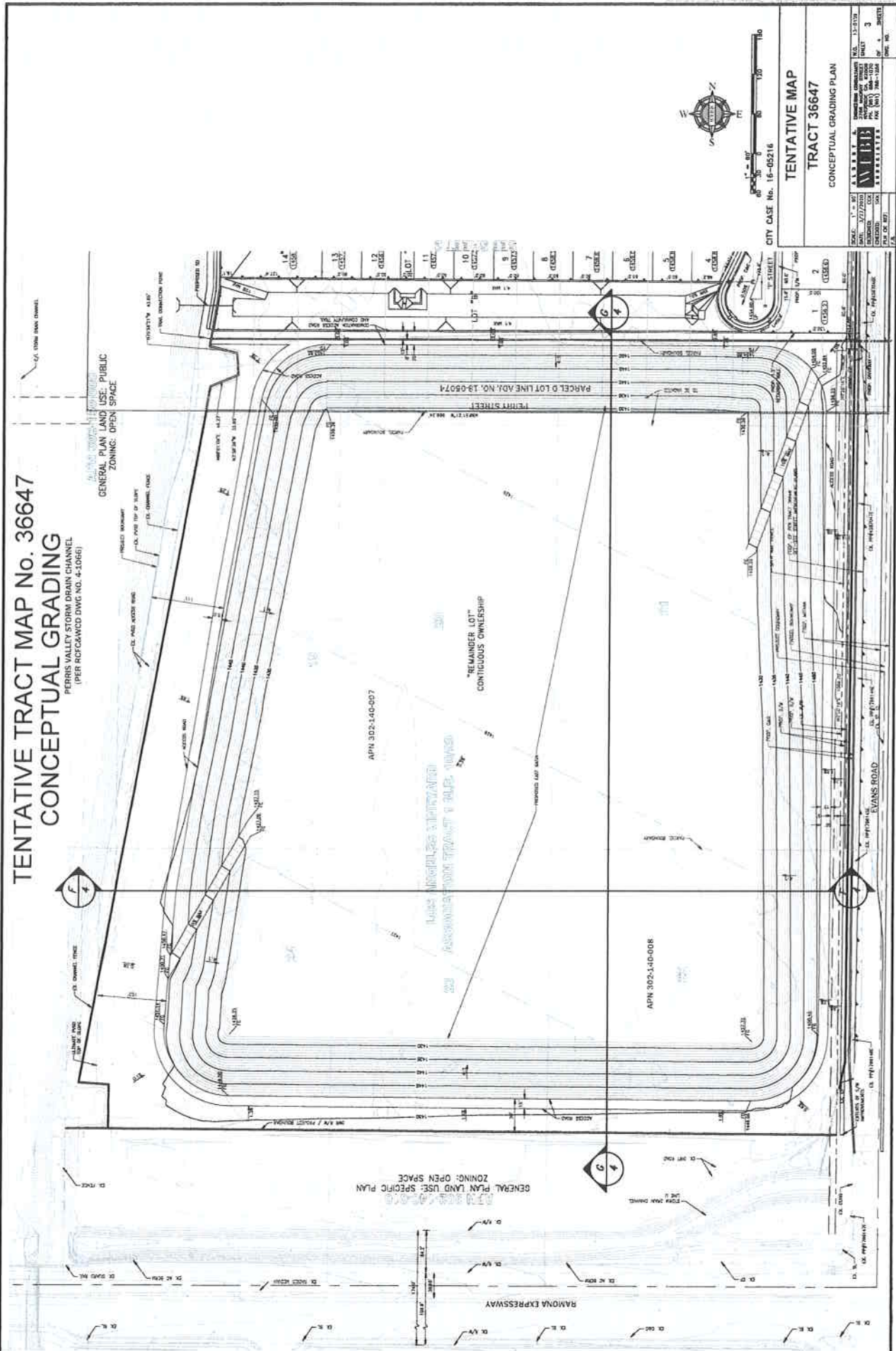

TENTATIVE MAP
TRACT 36647
CONCEPTUAL GRADING PLAN

CITY CASE No. 16-05216

| | | |
|----------------------|-----------------------|-----------------|
| DATE: 11-18-07 | APPROVED: [Signature] | SCALE: 1" = 30' |
| DRAWN: 02/12/08 | APPROVED: [Signature] | SHEET: 3 |
| CHECKED: [Signature] | APPROVED: [Signature] | OF 4 SHEETS |
| DATE: 02-07-07 | APPROVED: [Signature] | |

CONCEPTUAL LANDSCAPE PLANS TRACT 36647 - PERRIS, CA

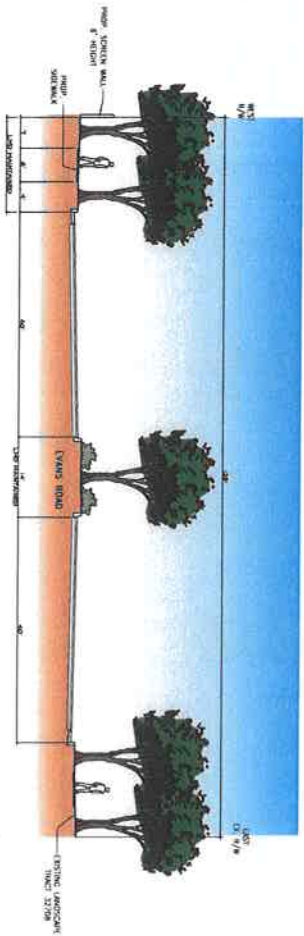

SECTION D-D

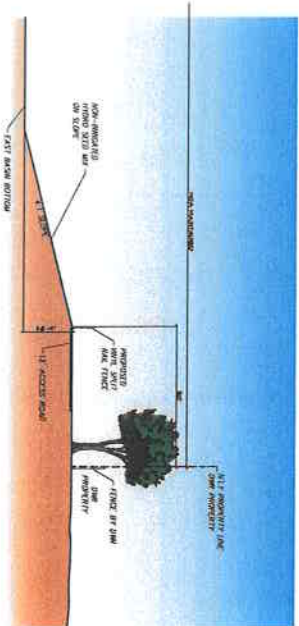

SECTION E-E

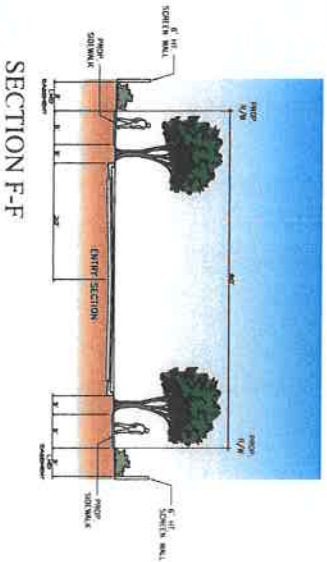

SECTION F-F

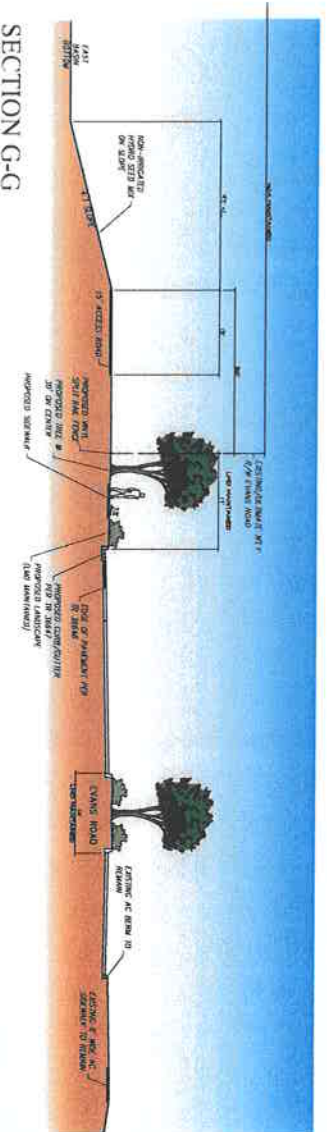

SECTION G-G

MISSION PACIFIC LAND COMPANY
4100 NEWBOLT PLACE, SUITE 400, NEWBOLT BLVD, CA 95660



HJL
HERMANN DESIGN GROUP
3000 WILSON
FARM 2211
1807 27th AVENUE
PERRIS, CA 92470
TEL: (951) 795-1111
FAX: (951) 795-1111
DATE: 4/22/20