



CITY OF PERRIS

PLANNING COMMISSION

AGENDA SUBMITTAL

MEETING DATE:

March 15, 2023

SUBJECT:

Development Plan Review 21-00018 - A proposal to construct a 37-unit condominium development on 1.82 acres located on the east side along G street at the terminus of E. 2nd Street, within the Urban Village (UV) Zone of the Perris Downtown Specific Plan (DTSP) (APN: 310-070-001 and 310-070-002). Applicant: Winston Liu of W&W Land Design Consultants, Inc.

REQUESTED ACTION:

Adopt Resolution No. 23-08, finding the project is Categorically Exempt from California Environmental Quality Act (CEQA) review pursuant to Section 15332 (In-fill Development Projects); and approving DPR 21-00018, based on the findings and subject to the Conditions of Approval.

CONTACT:

Kenneth Phung, Director of Development Services

BACKGROUND

The subject site is vacant and has a relatively flat terrain totaling approximately 1.8 acres. The site has never been developed or utilized for residential or commercial purposes. Surrounding uses include Perris Villas Apartments to the south, Diamond Environmental Services to the west across across G Street, County Hills Apartments to the west, and an existing single-family residence to the north. All the surrounding properties and the project site are zoned Urban Village, which allows 3 to 5-story stacked flats, rowhouses, courtyard housing, live-work, and mixed-use commercial block buildings. The proposed development follows the courtyard housing concept.

As a matter of information, staff conducted an Ad Hoc Committee for this Project on June 8, 2022. The Ad Hoc Committee expressed concerns related to architectural enhancements, color palette, walkability, and outdoor amenities. The applicant has revised the project plans to address the Ad Hoc Committee's concerns by modifying the architectural treatment to have a more traditional downtown architecture with additional veneer treatment with a contemporary flair to reflect the market demand for a modern downtown. Also, walkways have been incorporated to connect all the units to the street and to the outdoor amenities, which have been enhanced to include picnic benches, barbeque grills, and a tot lot. The Downtown Specific Plan does not have specified requirements for on-site recreational amenities for multi-family development, as it is anticipated that as the downtown develops, additional entertainment, recreational and cultural amenities will be close to those who reside in the downtown area. But outdoor amenities have been provided on the project site in response to the Ad Hoc Committee to afford the future residents of the project site recreational amenities as the City develops.

PROJECT DESCRIPTION

The applicant requests a Development Plan Review approval to construct a 37-unit condominium development on 1.82 acres. The proposed condominium development comprises 10 detached buildings containing 3 to 5 attached units.

Each unit has three levels; the ground level includes the main door, private patio, and a two-car garage; the second floor includes living areas, and the third floor includes bedrooms. A 33-foot-wide decorative driveway proposed along S. G street provides the main access to the site and is enhanced with a raised plant median. The project also includes centrally located common open space, parallel parking between curb bulb-outs, and a 10-foot landscape buffer for neighborhood character along the G street frontage. This development is not proposed to be gated, but the tot-lot will be gated for the residents' use only.

PROJECT ANALYSIS

The table below summarizes the project's consistency with the General Plan, DTSP Specific Plan, Zoning Code, Title 18 Subdivision Code, and March Air Reserve Base/Inland Port Airport Land Use Compatibility Plan.

	Consistent	Inconsistent
<p>Consistency with the General Plan</p> <p>The project site has a General Plan land use designation of UV – Urban Village. The intent of the Urban Village is to allow for mixed-use and multi-family residential buildings within walking distance of Downtown and the MetroLink Station. The Urban Village is envisioned to include an interior pedestrian paseo that provides access to downtown and the adjacent commercial district. Building heights may range from three to five stories, with parking provided on the streets as well as in parking structures and surface lots behind buildings. The proposed condominium development as conditioned, will be consistent with the General Plan.</p>	<input checked="" type="checkbox"/>	<input type="checkbox"/>
<p>Consistency with the Perris Downtown (DTSP) Specific Plan</p> <p>The project site is in the Urban Village Zone of the Downtown Specific Plan, which is intended for residential development that supports 3 to 5-story stacked flats, rowhouses, courtyards housing, live-work, and mixed uses. (Exhibit C). This project includes attached condominiums, and ancillary open space (courtyards) uses; therefore, it is consistent with the DTSP Specific Plan.</p>	<input checked="" type="checkbox"/>	<input type="checkbox"/>
<p>Consistency with the March Air Reserve Base/Inland Port Airport</p> <p>The proposed project is located within the March Air Reserve Base/Inland Port Airport Influence Area (March AIA.) Zone E (other Airport Environs). Zone E has no residential development restrictions. As the project is located in the downtown, consistency</p>	<input checked="" type="checkbox"/>	<input type="checkbox"/>

	Consistent	Inconsistent
<p>with the with the March Air Reserve Base/Inland Port Airport Land Use Compatibility Plan (MARB ALUCP), and the 2010/2011 Perris Valley Land Use Compatibility Plan is not required.</p> <p>On February 23, 2023, the Riverside County Airport Land Use Commission (ALUC) considered and determined that the Project is "Conditionally Consistent" with the 2014 March Air Reserve Base/Inland Port Airport Land Use Compatibility Plan (MARB ALUCP).</p>		

COMPLIANCE WITH APPLICABLE DEVELOPMENT STANDARDS

The table below summarizes compliance with the Downtown Specific Plan development standards.

Perris Downtown Specific Plan Urban Village Zone – Courtyard Flat Building Development Standards Development Standards					
Standard		Proposed	Consistent	Inconsistent	
Number of Stories	2 to 3 stories	1.0	<input checked="" type="checkbox"/>	<input type="checkbox"/>	
Building Height	75 -100 feet	35 feet	<input checked="" type="checkbox"/>	<input type="checkbox"/>	
Setbacks	Front Yard:	5 feet	10 feet	<input checked="" type="checkbox"/>	<input type="checkbox"/>
	Side Yards: - North - South	5 feet 5 feet	7 feet - 6 inches 8 feet- 4 inches	<input checked="" type="checkbox"/>	<input type="checkbox"/>
	Rear Yard (east)	5 feet	5 feet - 8 inches	<input checked="" type="checkbox"/>	<input type="checkbox"/>

Parking Standards Downtown Specific Plan – Parking Standards					
Use	Standard	Required	Proposed	Consistent	Inconsistent
Multi-Family	2 spaces/2 or more bedroom unit	74 spaces	74 spaces	<input checked="" type="checkbox"/>	<input type="checkbox"/>
	- 20 2-bedroom units - 17 3-bedroom units		8 guest spaces (not required)		
Total Parking		74 spaces	82 spaces	<input checked="" type="checkbox"/>	<input type="checkbox"/>
Total Surplus Parking			8 spaces	<input checked="" type="checkbox"/>	<input type="checkbox"/>

The project complies with the development standards for Courtyard Flat Building in the Urban Village Zone. It proposes 74 spaces in garages and 8 guest parking spaces, which exceed the minimum parking requirement of the Downtown Specific Plan for multi family residential, which is intended to provide an urban nature in the downtown, where retail businesses and offices are

located within walking distance, public transportation is more accessible than in suburban areas, and higher density residential development is promoted. Thus, as proposed, the project complies with the Downtown Specific Plan.

COMPLIANCE WITH OTHER APPLICABLE REQUIREMENTS

- **Building Elevations/Architecture**

The proposed building elevations reflect a contemporary architecture that emphasizes vertical elements contrasted by alternate decorative materials and colors. The design incorporates a combination of varying rooflines, vertical and horizontal windows, horizontal faux wood shiplap, brick veneer, and intermittent recessed panels to create a contrasting aesthetic design for compliance with the Perris Downtown Specific Plan design standards. The entry areas of the buildings are recessed to provide additional articulation in the vertical plane and covered entry ways. The proposed color palette combines warm shades of tans, white and copper to complement the buildings. The combination of varying colors, articulating footprint, variable roof height, enhanced cornice treatments, windows, etc., provides visual interest to the building.

- **Landscaping**

The applicant has submitted a conceptual landscape plan conforming to the Landscaping Ordinance's requirements. The proposed on-site landscaping area totals approximately 13,326 square feet or approximately 16.8% of the site. There is no minimum landscaping requirement in the Downtown Specific Plan; instead landscaping in the Downtown area is required to be provided in all setbacks to soften the street edge and large buildings, create a sense of place, screen parking areas and mechanical equipment, and enhance the pedestrian environment. The project proposes landscaping and decomposed granite along the street frontage. Additional landscaping is proposed along the perimeter of the site, guest parking area, common open space areas, and adjacent to the buildings. Staff is

The decomposed granite proposed along the street frontage and at the main entrance is recommended to be enhanced with plant materials to provide visual interest from the public right of way for compliance with the Downtown Specific Plan.

- **Fencing and Screening**

The project is required to construct a decorative 6-foot-high split-face concrete wall with a trim cap at the north and south sides of the property to buffer adjacent residential homes from noise and views associated with the residential project. The existing 6-foot-high block wall along the east property line will remain. A low decorative fence will be provided around the private patios for privacy.

- **Lighting**

All exterior lighting will provide one (1) foot-candle of illumination for pedestrian safety and security along all parking lots and pedestrian areas. All exterior lighting shall provide cut-off fixtures and will be downward facing away from the neighboring properties per City standards.

- **Amenity and Recreation area**

The applicant proposes common open space areas furnished with outdoor amenities including picnic benches, barbeque grills, and a tot lot.

ENVIRONMENTAL DETERMINATION

The Project is Categorically Exempt from California Environmental Quality Act (CEQA) review pursuant to Section 15332 (In-Fill Development Projects), as the project constitutes an infill development project within city limits on less than five acres of land in compliance with the applicable General Plan and Zoning Code and has no habitat value for biological resources.

RECOMMENDATION:

Adopt Resolution No. 23-08 finding the project is Categorically Exempt from the California Environmental Quality Act (CEQA) pursuant to Section 15332, Class 32 In-Fill Development Projects, and approving DPR 21-00018 to construct a 37-unit condominium community on 1.82 acres, based on the findings and subject to the Conditions of Approval.

BUDGET (or FISCAL) IMPACT: There is no fiscal impact associated with this project since all project costs are borne by the applicant.

Prepared by: Alfredo Garcia, Associate Planner
Reviewed by: Patricia Brenes, Planning Manager

EXHIBITS:

- A. Resolution 23-08 Approving Conditions of Approval (Planning, Engineering, Public Works, Fire, Community Services and Building & Safety)
- B. Location/Aerial Map
- C. Downtown Specific Plan Land Use Map
- D. Project Plans (Site, Floor, Elevations and Conceptual Landscape Plans)

Consent:
Public Hearing: X
Business Item:
Presentation:
Other:

EXHIBIT A

Reso 23-08 with Conditions of Approval
(Planning, Engineering, Public Works, Fire,
Community Services and Building)

RESOLUTION NUMBER NO. 23-08

A RESOLUTION OF THE PLANNING COMMISSION OF THE CITY OF PERRIS, COUNTY OF RIVERSIDE, STATE OF CALIFORNIA, FINDING THE PROPOSED PROJECT CATEGORICALLY EXEMPT FROM CEQA UNDER SECTION 15332, CLASS 32 IN-FILL DEVELOPMENT AND APPROVING DEVELOPMENT PLAN REVIEW 21-00018 TO CONSTRUCT A 37-UNIT CONDOMINIUM COMMUNITY ON 1.82 ACRES. THE PROJECT SITE IS LOCATED ON THE EAST SIDE ALONG G STREET AT THE TERMINUS OF E. 2ND STREET, WITHIN THE URBAN VILLAGE ZONE OF THE PERRIS DOWNTOWNSPECIFIC PLAN, SUBJECT TO CONDITIONS OF APPROVAL AND THE FINDINGS NOTED HEREIN.

WHEREAS, the applicant, Winston Liu , proposes to construct a 37-unit condominium community on 1.82 acres. The project site is located on the east side along G street at the terminus of E. 2nd Street, within the Urban Village (UV) Zone of the Perris Down Town Specific Plan (“Project”); and

WHEREAS, the Project’s proposed use is in accordance with the objectives of the Downtown specific plan Urban Village zone; and

WHEREAS, the Project’s proposed use is consistent with the City’s General Plan and conforms to all zoning standards and other relevant ordinances and resolutions of the City; and

WHEREAS, the applicant submitted a Development Plan Review application (DPR 21-00018) for the Project for consideration of architectural design and site layout; and

WHEREAS, the City has complied with the California environmental Quality Act, in that the Project is categorically exempt from review under the California Environmental Quality Act (CEQA) under Section 15332, Class 32 In-Fill Development; and

WHEREAS, a duly noticed public hearing was held on March 15, 2023, at which time all interested persons were given full opportunity to be heard and to present evidence; and

WHEREAS, Chapter 19.54 of the City of Perris Municipal Code (Zoning Code, Authority and Review Procedures) authorizes the City to approve, conditionally approve, or deny requests for a Development Plan Review; and

WHEREAS, prior to taking action, the Planning Commission has heard, been presented with, and/or reviewed all of the information and data which constitutes the administrative record for the above-mentioned approvals, including all oral and written evidence presented to the City during all Project meetings and hearings; and

WHEREAS, all other legal prerequisites to the adoption of this Resolution have occurred.

NOW, THEREFORE, BE IT RESOLVED by the Planning Commission of the City of Perris as follows:

Section 1. The above recitals are all true and correct and incorporated herein by this reference.

Section 2. The Planning Commission has determined that the Project is categorically exempt from review under the California environmental Quality Act (CEQA) under Section 15332, Class 32 In-Fill Development.

Section 3. Development Plan Review 21-00018. Based upon the forgoing and all oral and written statements and reports presented by City staff and members of the public, including, but not limited to, all such statements and reports (including all attachments and exhibits) presented at its public hearing on March 15, 2023, the Planning Commission finds, with respect to DPR 21-00018, that:

- 1. The location, size, design, density, and intensity of the proposed development and improvements are consistent with the City's General Plan and provisions of the Perris Municipal Code ("PMC"), the purposes of the Zone in which the site is located, and the development policies and standards of the City.*

The Project is zoned Urban Village. The intent of the Urban Village is to allow for mixed-use and multi unit residential buildings with first floor ancillary commercial uses within walking distance of Downtown and the MetroLink Station. The Urban Village is envisioned to include an interior pedestrian paseo that provides access to Downtown and the adjacent commercial district. Building heights would range from three to five stories, with parking provided on the streets as well as in parking structures and surface lots behind buildings.

The proposed location of the Project is in accordance with the objectives of the Development Plan Review provisions of the City's Zoning Code, Chapter 19.26, in that the proposed commercial building is desirable for the community and an appropriate use that provides a new area for the public to work and ensure compatibility with surrounding uses and protect the aesthetics and public, health and welfare of the community.

The proposed Project is consistent with the City's General Plan, meets the intent of the Urban Village zone and conforms to applicable provisions of the City's Zoning regulations in that appropriate conditions of approval have been developed to ensure that the use operates according to City policies and regulations to protect the public health and welfare.

2. *The proposed Project site is physically suitable, including but not limited to parcel size, shape, access, and availability of utilities and services, for the type of development proposed.*

The proposed location of the Project is in accordance with the objectives of the Development Plan Review provisions of the City's Zoning Code, Urban Village and Chapter 19.26 e, in that the proposed residential buildings are desirable for the community and appropriate use that provides a new area for the public to work and ensure compatibility with surrounding uses and protect the aesthetics and public, health and welfare of the community. The Project has been designed to meet with setbacks, FAR, coverages and landscape requirements as stated in the development standards of Urban Village Zone and Chapter 19.26. Furthermore, the site has been designed with added safety measures via traffic analysis as well as photometric review for added public safety and connection to all public utilities.

3. *The proposed Project and the conditions under which it would be operated or maintained is compatible with abutting properties and will not be detrimental to the public health, safety or welfare, or materially injurious to properties or improvements in the vicinity.*

As conditioned, the proposed Project will not be detrimental to the public health, safety or welfare, or injurious to property and improvements in the vicinity or to the general welfare of the City. Other high density residential projects currently exist in close proximity to the Project site. Traffic control signs currently exist along G Street and 2 Street street to help provide safe access /exit to the site as stated in the Conditions of Approval to ensure safe traffic conditions.

4. *The architecture proposed is compatible with community standards and protects the character of adjacent development.*

The Project proposes an architecturally enhanced buildings with varying roofline angles and heights, , wood ship lap siding and brick veneer. Colors on the façades range from white, tan and cooper which creates a modern yet warm palette. This meets the development standards of the Urban Village Zone.

5. *The landscaping plan ensures visual relief and provides an attractive environment for the public's enjoyment.*

The proposed Project meets or exceeds the on-site and off-site landscape standards for the Urban Village (UV) zoning district as outlined in the City of Perris Municipal Code, by providing a mix of specimen native and drought-tolerant trees, shrubs, ground cover, and annual color throughout the site to ensure visual relief and effectively frame, soften and embellish access points, building entries, parking areas, and trash enclosures.

6. *The safeguards necessary to protect the public health, safety and general welfare have been required for the proposed project.*

Section 4. Based upon the forgoing and all oral and written statements and reports presented by City staff and members of the public, including, but not limited to, all such statements and reports (including all attachments and exhibits) presented at its public hearing on March 15, 2023, the Planning commission finds the Project is exempt from review under the California Environmental Quality Act (CEQA) pursuant to Article 19 of the California Environmental Quality Act (CEQA) under section 15332, Class In-Fill development and approves Development Plan review 21-00018 to construct a 37-unit condominium community on 1.82 acres. The project site is located on the east side along G street at the terminus of E. 2nd Street, within the Urban Village (UV) Zone of the Perris Down Town Specific Plan, subject to the attached Conditions of Approval, which are attached hereto, and incorporated herein by this reference, as Attachment A.

Section 5. Based upon the forgoing and all oral and written statements and reports presented by City staff and members of the public, including, but not limited to, all such statements and reports (including all attachments and exhibits) presented at its public hearing on April 6, 2022.

Section 6. The Planning Commission declares that should include any provision, section, paragraph, sentence, or word of this Resolution be rendered or declared invalid by any court of competent jurisdiction, or by reason of any preemptive legislation, the remaining provisions, sections, paragraphs, sentences, and words of this Resolution shall remain in full force and effect.

Section 7. The Chairperson shall sign, and the Secretary shall certify to the passage and adoption of this Resolution.

ADOPTED, SIGNED and APPROVED this 15th day of March 2023.

CHAIRPERSON, PLANNING COMMISSION

ATTEST:

Secretary, Planning Commission

STATE OF CALIFORNIA)
 COUNTY OF RIVERSIDE) §
 CITY OF PERRIS)

I, Kenneth Phung, SECRETARY OF THE PLANNING COMMISSION OF THE CITY OF PERRIS, DO HEREBY CERTIFY that the foregoing Resolution Number 23-08 was duly adopted

by the Planning Commission of the City of Perris at a regular meeting of said Planning Commission on the 15th day of March 2023, and that it was so adopted by the following vote:

AYES:

NOES:

ABSTAIN:

ABSENT:

Secretary, Planning Commission

Attachments:

A. Conditions of Approval (Planning, Engineering, Public Works, Fire, and Building)

**CITY OF PERRIS
DEVELOPMENT SERVICES DEPARTMENT
PLANNING DIVISION**

PLANNING COMMISSION CONDITIONS OF APPROVAL

Development Plan Review 21-00018

March 15, 2023

PROJECT: Proposal to construct a 37-unit condominium community on 1.82 acres. The project site is located on the east side along G street at the terminus of E. 2nd Street, within the Urban Village (UV) Zone of the Perris Down Town Specific Plan (DTSP). APN: 310-070-001 and 002.

Applicant: Winston Liu of W&W Land Design Consultants, Inc.

General Requirements:

1. **Municipal Code and Specific Plan Compliance.** The project shall conform to the Downtown Specific Plan Urban Village zone standards of the city of Perris Municipal Code.
2. **Future Obligation of Buyers and Lessees.** All future buyers and lessees shall be informed of their obligation to comply with these Conditions of Approval. The applicant shall provide a copy of these conditions and inform the buyer or lessee of their obligation to maintain compliance with all local and City ordinances, including but not limited to an annual fire inspection and maintenance of a City business license.
3. **Expansion of Use.** No expansion of the site or the use shall occur without subsequent reviews and approvals from the Planning Division.
4. **Term of Approval.** This approval shall be used within three (3) years of approval date; otherwise it shall become null and void. By use is meant the beginning of substantial construction contemplated by this approval within the three (3) year period which is thereafter diligently pursued to completion, or the beginning of substantial utilization contemplated by this approval. A maximum of three (3) one-year time extensions shall be permitted.
5. **City Ordinances and Business License.** The subject business shall maintain compliance with all local and City Ordinances, including but not limited to an annual fire inspection and maintenance of a City business license.
6. **Payment of Notice of Exemption (NOE).** Within five (5) days of Planning Commission approval, the applicant shall file electronically a Notice of Exemption (NOE) and administrative \$50.00 fee to the "Riverside County Clerk's Office". A copy of the recorded NOE shall be provided to the Planning Division for record keeping purposes.
7. **Conformance to Approved Plans.** The proposed use will operate in accordance with the March 15, 2023 Planning Commission meeting approval, or as amended by these conditions. Any deviation shall require appropriate Planning Division review and approval.

8. **Graffiti** located on site shall be removed within 48 hours. The site shall be maintained in a graffiti-free state at all times. Graffiti shall be painted over in panels and not patches. In addition, will match color of wall or material surface. Furthermore, applicant shall apply an anti-graffiti coating on walls.
9. **Building & Safety Division.** The project shall comply with all Conditions of Approval by the Building and Safety Department dated January 16, 2021.
10. **ADA Compliance.** The project shall conform to all disabled access requirements in accordance with the State of California, Title 24, and Federal Americans with Disabilities Act (ADA).
11. **Fire Department Conditions.** The project shall comply with all Conditions of Approval by the Fire Department dated November 17, 2021, consisting of the following requirements.
 - a. Provide a fire flow report that has been completed within the last 6 months. The test flow shall be completed from the closest fire hydrant to the property. A minimum of 1,500 GPM @ 20 psi for 2-hours is required. CFC § 507.3
 - b. Provide a stand-alone fire department access plan. The fire department access plan shall show compliance with CFC § 503 and City of Perris Access Guideline and all applicable subsections. The guideline can be obtained <https://www.cityofperris.org/home/showpublisheddocument/2405/637216987049700000> . At a minimum the access plan shall address the following items:
 - Location of the access road. CFC § 503.1.1
 - Width of the access road. CFC § 503.2.1
 - Vertical clearance. CFC § 503.2.1
 - Inside and outside turning radii. CFC § 503.2.4
 - Road weight capacity. CFC § 503.2.3
 - Identify the type of roadway surface (concrete, asphalt, pavers, etc.). CFC § 503.2.3
 - Road grade (distinguish changes in 2.5% increments), CFC 503.2.7
 - Turn-arounds for dead-end access greater than 150' per CFC § 503.2.5 &
 - Location and details of “Fire Lane - No parking sign” and/or red curb marking CFC § 503.3
 - Location of all fire hydrants within 500 feet to the new structures. CFC § 507.5
 - Identify all gates/fences that obstruct the fire department path. CFC § 503.6
12. **Public Works.** The project shall adhere to the requirements of the Public Works Department as indicated in the attached Conditions of Approval dated March 8, 2022.
13. **City Engineering.** The Project shall comply with all requirements of the City Engineer’s Conditions of Approval dated February 10, 2023.

14. **Sign Application.** A separate sign application will be required for any signs.
15. **Indemnification.** The developer/applicant shall indemnify, protect, defend, and hold harmless, the City and any agency or instrumentality thereof, and/or any of its officers, employees and agents from any and all claims, actions, or proceedings against the City, or any agency or instrumentality thereof, or any of its officers, employees and agents, to attack, set aside, void, annul, or seek monetary damages resulting from an approval of the City, or any agency or instrumentality thereof, advisory agency, appeal board or legislative body including actions approved by the voters of the City concerning **Development Review (DPR) 21-00018**. The City shall promptly notify the applicant of any claim, action, or proceeding for which indemnification is sought, and shall further cooperate fully in the defense of the action.
16. **Southern California Edison (SCE).** The developer/owner shall contact Southern California Edison SCE area service planner (951 928-8323) to complete the required forms prior to commencement of construction. No grading permits shall be issued until a letter from SCE is received by the City Engineer indicating electrical service will be placed underground.
17. **Waste Hauling and Disposal.** The project shall use only the City-approved waste hauler for all construction and other waste disposal.
18. **On-site & Off-site Utilities.** All utilities attached to buildings, including meters and utility boxes, shall be painted to match the wall of the building to which they are affixed. These facilities shall also be screened from the public right-of-way by landscaping or physical barrier such as a wall.
19. **Site Lighting Plan.** The site lighting plan shall conform to the requirements of the City's adopted Mount Palomar Ordinance and be submitted to the Planning Division for final review and approval. Full cutoff fixtures shall be used to prevent light and glare above the horizontal plane of the bottom of the lighting fixture. A minimum of one (1) foot-candle of light shall be provided in parking and pedestrian areas. All lighting shall be shielded downward to prevent light pollution to spill over onto adjacent parcels.
20. **Trash Enclosure.** The trash enclosure shall be constructed as presented in the development plans approved by the Planning Commission.
21. **Screening of Roof-Mounted Equipment.** Proper screening shall prevent public views of all HVAC equipment.
22. **Outstanding Fees.** Any outstanding processing fees due to the Planning Division shall be paid.
23. **Construction Practices.** To reduce potential noise and air quality nuisances, the following items shall be listed as "General Notes" on the construction drawings:

- a. Construction activity and equipment maintenance is limited to the hours between 7:00 a.m. and 7:00 p.m., on weekdays. Construction may not occur on weekends or State holidays, without prior consent of the Building Official. Non-noise generating activities (e.g., interior painting) are not subject to these restrictions.
- b. Stationary construction equipment that generates noise in excess of 65 dBA at the project boundaries must be shielded and located at least 100 feet from occupied residences. The equipment area with appropriate acoustic shielding shall be designated on building and grading plans. Equipment and shielding shall remain in the designated location throughout construction activities.
- c. Construction routes are limited to City of Perris designated truck routes.
- d. Water trucks or sprinkler systems shall be used during clearing, grading, earth moving, excavation, transportation of cut or fill materials and construction phases to prevent dust from leaving the site and to create a crust after each day's activities cease. At a minimum, this would include wetting down such areas in the later morning and after work is completed for the day and whenever wind exceeds 15 miles per hour.
- e. A person or persons shall be designated to monitor the dust control program and to order increased watering as necessary to prevent transport of dust off-site. The name and telephone number of such persons shall be provided to the City. Also, a board shall be placed at the subject site to include person and phone number for the public to call in case of dirt and dust issues.
- f. Project applicants shall provide construction site electrical hook ups for electric hand tools such as saws, drills, and compressors, to eliminate the need for diesel powered electric generators or provide evidence that electrical hook ups at construction sites are not practical or prohibitively expensive.

24. Property Maintenance. The project shall comply with provisions of Perris Municipal Code 7.06 regarding Landscape Maintenance and Chapter 7.42 regarding Property Maintenance. In addition, the project shall comply with the one-year landscape maintenance schedule identified in Public Works Department Condition of Approval No. 5, dated March 08, 2022.

Prior to Building Permit Issuance:

28. Prior to building permit issuance, the applicant shall update the plans to provide a 36-inch wide concrete sidewalk between the southerly building wall and parking stalls. The landscaped finger areas shall be widened to align with the width of all emergency exits located at the southerly building wall to provide continuous connectivity of the concrete sidewalk.

29. **Fees.** The developer shall pay the following fees prior to the issuance of building permits:
- a. Stephen's Kangaroo Rat Mitigation Fees of \$500.00 per acre;
 - b. Multiple Species Habitat Conservation Plan fees currently in effect;
 - c. Current statutory school fees to all appropriate school districts;
 - d. Any outstanding liens and development processing fees owed to the City.
 - e. Appropriate City Development Impact Fees in effect at the time of development.
30. **Landscaping Plans.** Prior issuance of building permits, three (3) copies of Construction Landscaping and Irrigation Plans shall be submitted to the Planning Division for approval, accompanied by the appropriate filing fee. The landscape and irrigation plan shall be prepared by a California registered landscape architect and conformed to the requirements of Chapter 19.70 of the Municipal Code. The location, number, genus, species, and container size of the plants shall be shown. The landscaping shall be consistent with the conceptual landscape plan, except as required below. Plans shall be revised to include the following:
- a. The planter proposed to include decomposed granite proposed along the street frontage and at the main entrance shall include plant materials to provide visual interest from the public right of way for compliance with the Downtown Specific Plan.
31. **Wall and Fence Plan.** The project is required to erect a decorative 6-foot-high split face concrete wall with trim cap at the rear side of the property to buffer adjacent residential homes from noise and views associated with the proposed loading and parking areas..
32. **Construction Plans.** All Planning Division and Engineering Department Conditions of Approval, shall be reproduced in full on construction drawings and grading plans, immediately following the cover sheet of such plans. Each Condition shall be annotated on the construction plans for ease of reference (i.e., sheet and detail numbers).

Prior to Grading Permit Issuance:

33. **Precise Grading Plans.** Precise grading plans shall be submitted to the City Engineer for review and approval. Grading plans shall be consistent with approved development plans.
34. **Final Water Quality Management Plan (FWQMP).** Prior to issuance of grading permits a FWQMP is required to be submitted. To mitigate impacts related to pollutant loading to receiving waters and/or increased erosion/siltation resulting from the long-term operation of the project, the applicant shall develop, receive approval from the City, and implement a FWQMP. The FWQMP shall contain measures that will effectively treat all pollutants of concern and hydrologic conditions of concern, consistent with the Preliminary WQMP and developed in compliance with the MS4 permit. The FWQMP shall specifically identify pollution prevention, source control, treatment control measures, and other Best Management Practices (BMPs) that shall be used on site to control predictable pollutant runoff to reduce impacts to water quality to the maximum

extent practicable. The FWQMP shall substantially comply with site design, source control and treatment control BMPs proposed in the approved Preliminary Water Quality Management Plan (PWQMP).

Prior to Issuance of Occupancy Permits:

35. **Assessment and Assessment and Community Facilities Districts.** The project shall be annexed into any assessment, community facilities, or similar district that provides funding for maintenance, services, or public improvements that benefit the project. The costs and benefits shall be described in the applicable district and annexation documents. The developer shall complete all actions required to complete such annexation prior to issuance of a Certificate of Occupancy. See Public Works/Engineering Conditions of Approval.
36. **On-Site Landscape Inspections.** The project applicant shall inform the on-site project manager and the landscape contractor of their responsibility to call for final landscape inspection after all the landscaping and irrigation has been installed and is completely operational. Before calling for a final inspection, a "Certificate of Compliance" form shall be completed and signed by the designer/auditor responsible for the project, and submitted to the project planner for approval.
37. **Final Inspection.** The applicant shall obtain occupancy clearance from the Planning Division by scheduling a final Planning inspection after final sign-offs from the Building Division and Engineering Department. Planning Staff shall verify that all pertinent conditions of approval have been met. The applicant shall have all required paving, parking, walls, site lighting, landscaping and automatic irrigation installed and in good condition.

END OF CONDITIONS

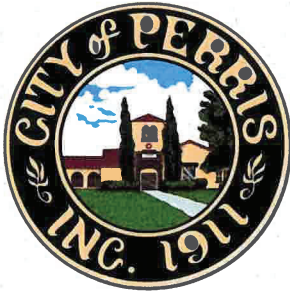

CITY OF PERRIS

STUART E. MCKIBBIN, CONTRACT CITY ENGINEER

CONDITIONS OF APPROVAL

P8-1502
February 10, 2023
DPR 21-00018 – TTM 38308
Grace Su
G St. at 2nd St.
APNs 310-070-001 & -002
Lots A & B – Blk 3 – MB 016/078

With respect to the Conditions of Approval for the above referenced project, the City of Perris requires that the developer provide the following street improvements and/or road dedications in accordance with the City of Perris Municipal Code Title 18. It is understood that the site plan correctly shows all existing and proposed easements, traveled ways, rights-of-way, and drainage courses with appropriate Q's and that their omission may require resubmittal for further consideration. These Ordinances and the following conditions are essential parts and requirements occurring in one is as binding as though occurring in all. They are intended to be complimentary and to describe the conditions for a complete design of the improvements. Unless otherwise noted, all offsite improvements as conditions shall be installed prior to issuance of any occupancy permits. All questions regarding the true meaning of the conditions shall be referred to the City Engineer's office.

In the event of a conflict between any conditions stated below, those imposed by Planning Department and others, and requirements identified in the approved Traffic Impact Analysis, the most stringent in the opinion of the City shall prevail.

General Conditions:

1. The developer/property owner shall secure City's and appropriate agencies clearances and approvals of the improvement plans.
2. The project grading shall be in a manner to perpetuate existing natural drainage patterns. Any deviation from this, concentration or increase in runoff must have approval of adjacent property owners and

DEPARTMENT OF ENGINEERING
24 SOUTH D STREET, SUITE 100, PERRIS, CA 92570
TEL.: (951) 943-6504 - FAX: (951) 943-8416

City Engineer. The developer/property owner shall accept the offsite runoff and convey to acceptable outlet.

3. Prior to commencement of any construction or installation of fencing in public right-of-way, an encroachment permit shall be obtained from the City Engineer's office.

Prior to Recordation of the Tract Map:

4. The developer/property owner shall have approved improvement plans, executed subdivision agreement and posted securities.

5. The developer/property owner shall submit the following to the City Engineer for review and approval:

- a. Onsite Precise Grading Plan and Erosion Control Plans; plans shall show the WDID No.
- b. Street Improvement Plans
- c. Storm Drain Improvement Plans
- d. Signing and Striping Plans
- e. Water and Sewer Improvement Plans
- f. Street Light Plans prepared by a registered Electrical Engineer per City of Perris Safety Lighting Standards
- g. Geotechnical Report
- h. Hydrology and Hydraulic Report
- i. Final WQMP (for reference)

The design shall be in conformance with Eastern Municipal Water District (EMWD), Riverside County Flood Control and Water Conservation District (RCFCD), Riverside County Transportation Department, Caltrans, City of Perris and ADA most recent standards, criteria and requirements and in effect at the time of construction and shall be coordinated with the approved plans of the adjacent developments.

6. G Street is classified as a Collector (60'/40') per the General Plan. Adequate right-of-way shall be dedicated on G Street along the property frontage to accommodate a 30 foot half width dedicated right-of-way.

7. All rights-of-way and easements shall be offered for dedication to the public or other appropriate agencies and shall continue in force until the City or the appropriate agency accepts or abandons such offers. All dedications shall be free from all encumbrances as approved by the City Engineer.

8. Relinquish and waive rights of access to and from G Street on the Map other than the access opening as shown on the tentative map.

9. In the event that offsite property is required to complete the improvements, the developer/property owner shall make a good faith effort to acquire required offsite property interests, and if he or she should fail to do so, the developer/property owner shall, prior to submittal of the Final Map for recordation, enter into an agreement to complete the improvements. The agreement shall provide for payment by the developer/property owner of all costs incurred by the City to acquire the offsite property interests required in connection with the subdivision. Security of a portion of these costs shall be in the form of a cash deposit in the amount given in an appraisal report obtained by the developer/property owner (at developer/property owner cost). The appraiser shall be approved by the City prior to commencement of the appraisal.

10. The developer/property owner shall sign the consent and waiver form to join the City's Lighting and Landscape Districts and City's Flood Control District as appropriate. The proposed and existing streetlights and traffic signals shall be maintained by the City and cost paid by the developer/property owner through the said annexation.

Prior to Issuance of Grading Permit:

11. The developer/property owner shall submit the following to the City Engineer for review and approval:

- a. Onsite Precise Grading Plan and Erosion Control Plans; plans shall show the WDID No.
- b. Street Improvement Plans
- c. Storm Drain Improvement Plans
- d. Signing and Striping Plans
- e. Street Light Plans prepared by a registered Electrical Engineer per City of Perris Safety Lighting Standards
- f. Geotechnical Report
- g. Hydrology and Hydraulic Report
- h. Final WQMP (for reference)

The design shall be in conformance with EMWD, RCFCD, Riverside County Transportation Department, Caltrans, City of Perris and ADA most recent standards, criteria and requirements and in effect at the time of construction and shall be coordinated with the approved plans of the adjacent developments.

12. All generated onsite and offsite runoff shall be collected and conveyed via underground drainage facilities and shall be connected to the existing storm drain system in G Street.

13. The ramps at the driveway shall include wet set concrete truncated domes in compliance to ADA standards and requirements.

Prior to Issuance of Building Permit:

14. Water and sewer Improvement Plans, per Fire Department and EMWD standards, shall be submitted to the City Engineer for review and approval.

15. Fire Department approval of the Water Improvement Plan is required prior to City Engineer's approval.

16. Paved access shall be provided to the proposed buildings per the Precise Grading Plans.

17. The developer/property owner shall submit a compaction certification from the Soils Engineer in compliance with the approved geotechnical/soils report.

Prior to Issuance of Certificate of Occupancy:

18. G Street (Collector - 60'/40') along the property frontage within the dedicated right-of-way shall be improved to provide for a 30 foot wide AC pavement (using a TI of 6.0 and PG 64-10), 6 inch curb and gutter generally located 18 feet east of street centerline, 6 foot wide sidewalk and streetlights subject to the photometric analysis, per City of Perris, County of Riverside and Caltrans standards.

The street design, bulbouts, sidewalk extensions, crosswalks, and paving materials shall be per Downtown Specific Plan standards as approved by Planning Department, Public Works Department and the City Engineer.

19. The conditions of the existing pavement on G Street along the property frontage shall be evaluated by the developer/property owner to determine the extent of pavement rehabilitation as approved by City Engineer. If the existing pavement is in good condition, the developer/property owner may use grind and overlay technique as determined by the City Engineer.

20. The developer/property owner shall provide for utility trench surface repair as directed by the City Engineer.

21. Associated existing signing and striping shall be refreshed and any appurtenances damaged or broken during the development of this project shall be repaired or removed and replaced by the developer/property owner to the satisfaction of the City Engineer. Any survey monuments damaged or destroyed shall be reset by qualified

professional pursuant to the California Business and Professional Code
8771.

Stuart E. McKibbin
Contract City Engineer



CITY OF PERRIS

PUBLIC WORKS DEPARTMENT

Weed Abatement

NPDES Services

Flood Control and Landscape Districts

MEMORANDUM

Date: March 08, 2022

To: Alfredo Garcia, Planner

From: Michael Morales, CIP Manager

By: Chris Baldino, Landscape Inspector CB

Subject: DPR 21-00018 – Conditions of Approval

Proposal of a 37-unit residential development Condominium Project on 1.82 acres. Located within the Downtown Specific Plan on G Street at terminal of 2nd Street.

-
1. **Dedication and/or Landscape Maintenance Easement.** Offer of Dedication and Landscape Maintenance Easement for City landscape maintenance district shall be provided as follows:
 - **G Street** - Provide offer of dedication as needed to provide for full half width Street (60' ROW / 30' Half width, curb gutter, sidewalk, and off-site landscaping requirements, per City General Plan, including a minimum public parkway plus an additional 2' of landscape easement, totaling a 12' public parkway from face of curb. Provide a colored concrete intersection with stamped concrete crosswalk.
 2. **Landscape Maintenance Easement and Landscape Easement Agreement.** The developer shall provide, for review and approval, an Offer of Dedication and certificate of acceptance, complete with legal plat map and legal description to the City of Perris. In addition, if required by the City of Perris, the Developer shall provide a landscape easement and Landscape easement agreement of 1 additional foot for parkway landscaping, acceptable to the City of Perris. The City shall record the same with the Riverside County Recorder's Office, and the recorded instrument shall be returned to the City Clerk of the City of Perris for filing.
 3. **Landscaping Plans.** Three (3) copies of Construction Landscaping and Irrigation Plans for the off-site landscaping, including any medians or other landscape areas along the dedications shall be submitted to the Planning Department for approval and shall be accompanied by the appropriate filing fee. The landscape and irrigation plan shall be prepared by a registered landscape architect and conform to the requirements of Chapter 19.70 of the Municipal Code. The location, number, genus, species, and container size of the plants shall be shown. This landscape plan shall be titled "Off-site Landscape Plan for **DPR 21-00018**" and shall be exclusive of any private property, on-site landscaping. Elements of the Landscape Plan shall include but not be limited to:
 - a. **Landscape Limits** – Limits of right-of-way areas or easement areas, defined by concrete mow curb, fully dimensioned, that are to be annexed into the Landscape Maintenance District. A planting palette and hardscape plan intended to meet the design intent of the Landscape Guidelines in effect for the area; or if no such guidelines exist the design intent of neighboring development, as determined by the Engineering

Administration and Special Districts Division, including:

- **G Street** – Developer shall be required to install new landscape and irrigation within new parkway along G street. Trees to be Koelreuteria Bipinnata, 'Chinese Flame Tree'. Use of drought resistant shrubs and groundcover, including but not limited to the following: Raphiolepis, Kanagarro Paws, Dietes Bicolor, Hermercolasis Hybrid Day Lily, Nandina Domestica Harbor Dwarf and Myoporum parvifolium 'Putha Creek'.
 - **Decorative Double Head Street Light** – The Developer shall be required to provide decorative streetlights with a third pedestrian luminaire per the Downtown Specific Plan.
 - **Decorative Intersection at G Street and 2nd Street / Crosswalk** – The developer shall be required to install a Mid decorative intersection at 2nd & G street. Crosswalks shall be constructed of decorative colored concrete pavement (stamped colored concrete) to clearly mark the pedestrian crossing zone, per sections 3.4 Vision Plan and 5.6 Street Standards, of the Downtown Specific Plan. Colors shall match colors provided in the D street Public Area Enhancement Plan.
- b. **Irrigation** – A list of irrigation system components intended to meet the performance, durability, water efficiency, and anti-theft requirements for Special District landscape areas as determined by the Engineering Administration and Special Districts Division. Components shall include, but not be limited to Salco or equal on flexible PVC risers, Sentry Guard Cable Guard and Union Guard, and backflow Wilkens Model 375 (or equal). Controller shall include an ET based controller with weather station that is centrally controlled capable and wi-fi ready (WeatherTrak ET Pro3 Smart Controller, or equal, with Rain Sensor). At the discretion of the Engineering Administration and Special Districts Division public landscape areas utilizing no more than 6 valves/stations, programmed to irrigate consecutively, and none simultaneously, may propose the use of an alternative ET based controller with weather station that is centrally controlled capable and wi-fi ready, such as the Weathermatic System or equal. Proposed system shall be complete with wireless weather station, aircard with flow, one year bundle service, blade antenna and flow sensor.
- c. **Benefit Zone Quantities** – Include a Benefit Zone quantities table (i.e. SF of planting areas, turf, number of trees, SF. of hardscape, etc.) in the lower right hand corner of the cover sheet for off-site landscape areas, indicating the amount of landscaping the district will be required to maintain.
- d. **Meters** – Each District is required to be metered separately. All electrical and water meters shall be located in locations that are easily accessible to maintenance staff while not visually obtrusive in the street scene and away from street intersections. Show location of separate water and electrical utility meters intended to serve maintenance district areas exclusively. Show locations of water and electrical meter for landscape district. Show location of water and electrical meter for flood control district. Show location of electrical meter for Traffic signal and street lighting district, on respective plans. Coordinate location of meters on landscape and civil engineering plan.
- e. **Controllers** - The off-site irrigation controllers are to be located within the right of way (preferably within the off-site landscape area). All point of connection equipment including irrigation controller pedestals, electrical meter pedestals, and backflow preventers are to be located in locations that are easily accessible to maintenance staff while not visually obtrusive in the street scene, and away from street intersections. Backflow preventers are to be screened on at least three sides with (5) gallon plant material. The fourth side shall be open to the back of the landscape area in order to allow the backflow cage to be opened without interference with plant materials. Backflow cages shall meet the required City of Perris Engineering

Standards in effect at the time of approval.

- f. **Recycled Water** - If applicable. The project landscape architect shall coordinate with EMWD to verify if the site will be served with recycled water and design all irrigation and landscape plans to meet the requirements of EMWD and provide additional irrigation components as needed.
 - g. **EMWD Landscape Plan Approval** – The project landscape architect shall submit a copy of all irrigation plans and specifications to EMWD for approval. The project landscape architect must confirm with EMWD that the plans have been approved by EMWD and submit written proof of approval by EMWD prior to the City approving the final Landscape Plans. Until the final landscape plan has been approved by the City of Perris, the maintenance areas depicted cannot be accepted by the City for maintenance. The developer shall coordinate both reviews to ensure acceptability of plans by both EMWD and the City of Perris, prior to approval by either agency.
 - h. **Landscape Weed Barrier** - Weed cloth with a minimum expected life of 10-years shall be required under all gravel, rock, or cobble areas.
 - i. **Wire Mesh and Gravel at Pull Boxes**- Provide wire mesh and gravel layer within valve boxes to prevent rodent intrusion.
 - j. **Concrete Maintenance Band at Medians and Mortar Cobble turn Land** – Provide 12” wide concrete maintenance band (safety edge) around entire median. At turn pockets provide mortared cobble creek bed, round stone sized 6” to 12”.
 - k. **Perimeter Walls Graffiti Coating** – Provide anti-graffiti coating at all perimeter walls. Acceptable products shall include Vitrocem Anti-Graffiti Coating or equal.
4. **Landscape Inspections.** The project applicant shall inform the on-site project manager and the landscape contractor of their responsibility to call for only “OFF-SITE” landscape and irrigation inspections at the appropriate stages of construction. Inspections shall be scheduled at least two-working days (Monday through Friday) prior to actual inspection. Contact Public Works-Engineering Administration/Special Districts at (951) 657-3280 to schedule inspections.
- **Inspection #1** - Trenches open, irrigation installed, and system pressurized to 150 PSI for four hours.
 - **Inspection #2** - Soil prepared, and plant materials positioned and ready to plant.
 - **Inspection #3** - Landscaping installed, irrigation system fully operational, and request for “Start of 1 year Maintenance Period” submitted, with all required turn-over submittal items provided to Public-Works Engineering Administration/Special Districts.
 - **Turn-Over Inspection**– On or about the one-year anniversary of Inspection #3, Developer shall call for an inspection to allow the City to review and identify any potential irrigation system defects, dead plants, weed, debris or graffiti; stressed, diseased, or dead trees; mulch condition, hardscape or other concerns with the landscape installation; or to accept final turn over of the landscape installation. At his sole expense, the Developer shall be responsible for rectifying system and installation deficiencies, and the one-year maintenance period shall be extended by the City until all deficiencies are cured to the satisfaction of the City. If in the opinion of the City’s Landscape Inspector the landscape installation is in substantial compliance with the approved landscaping plans, the irrigation and communication

system is functioning as intended, and the landscape installation is found to be acceptable to the City, then the Inspector shall recommend to the City's Special District Coordinator to accept turn-over of water and electrical accounts, wi-fi communication contracts and the entire landscape installation.

5. **One Year Maintenance and Plant Establishment Period**-The applicant will be required to provide a minimum of a one (1) year maintenance and plant establishment period, paid at the sole expense of applicant. This one-year maintenance period commences upon the successful completion of Inspection #3 discussed above, and final approval by the City. During this one-year period the applicant shall be required to maintain all landscape areas free of weeds, debris, trash, and graffiti; and keep all plants, trees, and shrubs in a viable growth condition. Prior to the start of the one-year maintenance period, the Developer shall submit a weekly Landscape Maintenance Schedule for the review and approval by the City's Special Districts Division. City shall perform periodic site inspections during the one-year maintenance period. The purpose of these periodic inspections is to identify any and all items needing correction prior to acceptance by the City at the conclusion of the one-year maintenance period. Said items needing correction may include but are not limited to: replacement of dead or diseased plant materials, weeding, replenishment of mulches, repair of damaged or non-functioning irrigation components, test of irrigation controller communications, etc. During this period, the City shall begin the annual assessment of the benefit zone in preparation for the landscape installation turn-over to City maintenance staff.
6. **Street/Off-Site Improvements.** The applicant shall submit street improvement plans, accompanied by the appropriate filing fee to the City Engineering Department. Details of treatments off-site improvements, including lighting shall meet both the City Engineer's Design Guidelines, and the additional requirements of the Engineering and Special Districts Division. Components shall include, but not be limited to:
 - a. **Street Lighting**-If Street lighting is required, lighting shall meet the type, style, color and durability requirements, necessary for energy efficiency goals, maintenance and longevity of improvements of the City Engineer's Office. As determined by the City, new streetlights may be required to be deeded to City of Perris, and not SCE. Street lights deeded to City of Perris shall be constructed per LS-3 account billing standard, which shall include an individually metered pedestal for streetlights.
 - b. **Acceptance By Public Works/Special Districts**- Lighting District facilities required by the City Engineer's Office shall be installed and fully operational and approved by final inspection by the City Engineer's Office, and the City's Consulting Traffic Signal Inspection Team (Riverside County TLMA) at (951) 955-6815. Prior to acceptance for maintenance of "Off-site" traffic signal and lighting facilities by the Public Works-Engineering and Administration Division/Special Districts, the developer shall contact the Public Works Special Districts Division at (951) 657-3280 to schedule the delivery of all required turn-over submittal items. Prior to acceptance into Lighting District 84-1, coordinate turn-over information pertaining to Street Lights, and Traffic Signal Electrical/SCE Service Meters with Wildan Financial Services, the City's Special Districts Consulting Firm at (951) 587-3564. (i.e. Provide electrical meter number, photo of pedestal, and coordinate "request for transfer of billing information" with SCE and City for all new service meters). Developer shall pay 18-month energy charges to the City of Perris for all off-site street lighting. Call Wildan Financial Services, Inc. for amount due, and to obtain receipt for payment. Obtain and provide a clearance form from Riverside County TLMA indicating completion of all punch list items from traffic signal construction. Submit one large format photo-copy of Traffic Signal as-built plans and timing sheets.
7. **Water Quality Management Plans.** The applicant shall submit a Preliminary and Final WQMP, accompanied by the appropriate filing fee to the Planning Department and City Engineering Department, respectively. Details

for treatment control facilities shall meet both the Riverside County WQMP Design Guidelines, and the additional requirements of the Engineering and Special Districts Division intended to reduce long term maintenance costs and longevity of improvements. Components shall include, but not be limited to:

- **Storm Drain Screens**-If off-site catch basins are required by the City Engineer's Office, connector pipe screens shall be included in new catch basins to reduce sediment and trash loading within storm pipe. Connector pipe screens shall meet the type, style, and durability requirements of the Public Works Engineering Administration and Special Districts Division.
- **WQMP Inspections**- The project applicant shall inform the on-site project manager and the water quality/utilities contractor of their responsibility to call for both "ON-SITE" and OFF-SITE" WQMP Inspections at the appropriate stages of construction. Contact CGRM at (909) 455-8520 to schedule inspections.
- **Acceptance By Public Works/Special Districts**-Both on-site and off-site flood control/water quality facilities required for the project, as depicted in the Final WQMP, shall be installed and fully operational, and approved by final inspection by the City's WQMP Consultant, CGRM. The Developer shall obtain a final Clearance Letter from CGRM indicating compliance with all applicable Conditions of Approval for the approved WQMP. The developer shall deliver the same to the Public Works-Engineering and Administration Division/Special Districts. In addition, prior to acceptance by the City, the developer shall submit a Covenant and Agreement describing on-going maintenance responsibilities for on-site facilities per the approved WQMP, to the Public Works Engineering Administration and Special Districts Division. The Public Works Engineering Administration and Special Districts Division will review and approve the Covenant and Agreement. The City shall record the same with the Riverside County Recorder's Office, and the recorded instrument shall be returned to the City Clerk of the City of Perris for filing.

8. **Flood Control District #1 Maintenance Acceptance.** Flood Control District facilities required by the City Engineer's Office shall be installed and fully operational, and approved by final inspection by the City Engineer's Office. Prior to acceptance for maintenance of "Off-site" flood control facilities by the Public Works-Engineering and Administration Division/Special Districts the developer shall contact the Public Works Special Districts Division at (951) 657-3280 to schedule the delivery of all required turn-over submittal items including as-built storm drain plans in electronic PDF format, one large format photo-copy of as-built plans, storm drain video report in electronic format, and hardcopy of video report with industry standard notations and still photos made during video runs (i.e. facilities sizes, off-sets or damage, facility type, dirt and debris, etc.). The flood control facilities shall be turned over in a condition acceptable to the City, and the developer shall make all necessary repairs and perform initial maintenance to the satisfaction of the City.
9. **Assessment Districts.** Prior to permit issuance, developer shall deposit \$5,250 per district, \$15,750 total due. Payment is to be made to the City of Perris, and the check delivered to the City Engineer's Office. Payment shall be accompanied by the appropriate document for each district indicating intent and understanding of annexation, to be notarized by property owner(s):
 - **Consent and Waiver for Maintenance District No. 84-1** – New decorative street lighting proposed by the project, as determined by the City Engineer
 - **Consent and Waiver for Landscape Maintenance District No. 1** – New off-site parkway landscape and decorative intersection proposed by the project on G Street.

- **Petition for Flood Control Maintenance District No. 1** -For Off-site Flood Control Facilities proposed by the project, as determined by the City Engineer.
- Original notarized document(s) to be sent to:
Daniel Louie
Wildan Financial Services
27368 Via Industria, #200
Temecula, CA 92590
- a. Prior to final map recordation or final certificate of occupancy the developer shall annex into the aforementioned districts, posting an adequate maintenance performance bond to be retained by the City as required by the City Engineer. Upon receipt of deposit and Consent and Waiver Forms, the developer shall work with City to meet all required milestones for annexations.
- i. City prepares the Engineer's Reports which includes a description of the improvements to be maintained, an annual cost estimate and annual assessment amounts.
- ii. Reports are reviewed and approved by the property owner. The assessment ballots will be based on these Reports.
- iii. The Reports and corresponding resolutions are placed, for approval, on the City Council Meeting Agenda. City Council action will include ordering the assessment ballots and setting a Public Hearing for no sooner than 45 days. Property owner attendance at this City Council Meeting is not required.
- iv. The assessment ballots are sent to the property owner and are opened by the City Clerk at the close of the Public Hearing. With a "YES" vote by the property owner the City Council can move forward with the Resolution that Confirms the Annexation. Property owner attendance at this Public Hearing is not required.
- v. Confirmation by the City Council completes the annexation process and the condition of approval has been met.

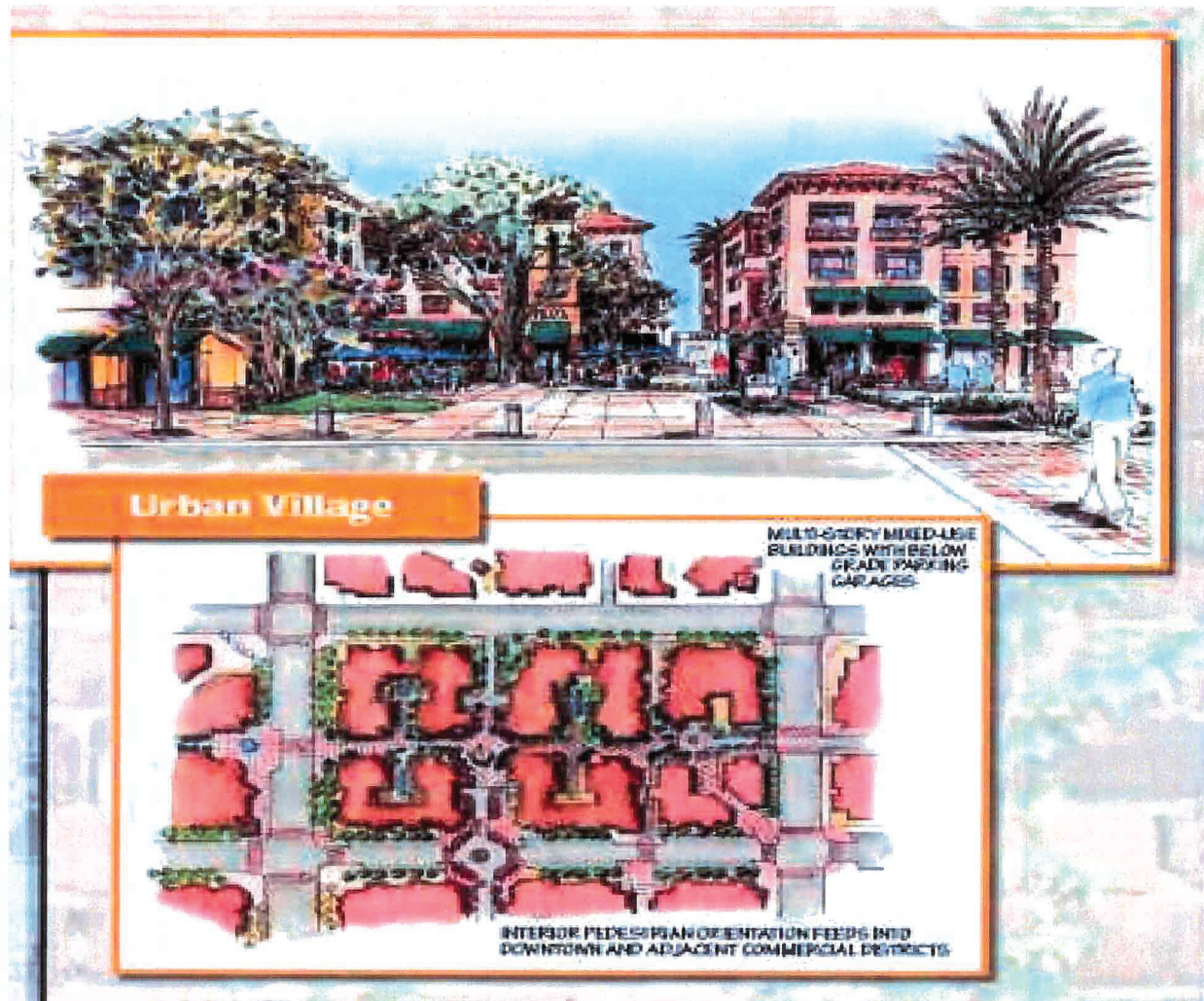

D. INTERSECTION AND CROSSWALK STANDARDS

1. To reduce the length of pedestrian crosswalks and the speed of turning vehicles at intersections, the curb radius at street intersections should not exceed 12 feet unless necessary for emergency vehicle access or to accommodate turning movements along secondary arterial streets and major collector streets, which may require turning radii of 15 feet or greater.
2. Crosswalks are required at all street intersections along D Street and within 1,320 feet (one quarter mile) of the train station. Mid-block crosswalks may be provided to allow greater connectivity for pedestrians. Intersection and mid-block crosswalks in other locations are encouraged to provide safe crossing areas for pedestrians. Crosswalks should be constructed of decorative pavement to clearly mark the pedestrian crossing zone and to help slow the speed of vehicles entering an intersection.
3. Bulbouts (extensions of the sidewalk into the parking aisle) are encouraged along D Street and at intersections with heavy pedestrian traffic. Bulbouts shall be constructed with paving materials that are consistent with the adjacent sidewalk.

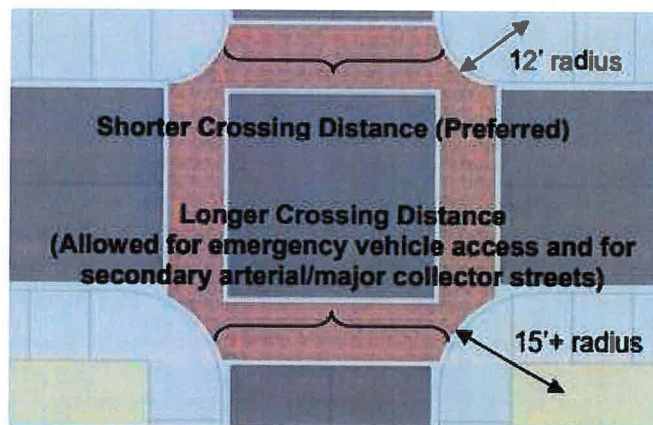

Turning radius at intersections





Dennis Grubb and Associates, LLC

Assisting Cities Build Safe Communities

Fire Department Development Review Comments

November 17, 2021

City of Perris
Attn: Alfredo Garcia
135 N. D Street
Perris, CA 92570-2200

Subject: Development Plan Review for DPR 21-00018

As requested, a review of the subject property was completed. The following fire conditions shall apply:

1. Provide a fire flow report that has been completed within the last 6 months. The test flow shall be completed from the closest fire hydrant to the property. A minimum of 1,500 GPM @ 20 psi for 2-hours is required. CFC § 507.3
2. Provide a stand-alone fire department access plan. The fire department access plan shall show compliance with CFC § 503 and City of Perris Access Guideline and all applicable subsections. The guideline can be obtained <https://www.cityofperris.org/home/showpublisheddocument/2405/637216987049700000> . At a minimum the access plan shall address the following items:
 - Location of the access road. CFC § 503.1.1
 - Width of the access road. CFC § 503.2.1
 - Vertical clearance. CFC § 503.2.1
 - Inside and outside turning radii. CFC § 503.2.4
 - Road weight capacity. CFC § 503.2.3
 - Identify the type of roadway surface (concrete, asphalt, pavers, etc.). CFC § 503.2.3
 - Road grade (distinguish changes in 2.5% increments), CFC 503.2.7
 - Turn-arounds for dead-end access greater than 150' per CFC § 503.2.5 &
 - Location and details of "Fire Lane - No parking sign" and/or red curb marking CFC § 503.3
 - Location of all fire hydrants within 500 feet to the new structures. CFC § 507.5
 - Identify all gates/fences that obstruct the fire department path. CFC § 503.6

Respectfully,

Dennis J. Grubb CFPE



CITY OF PERRIS

COMMUNITY SERVICES

MEMO

Date: March 8, 2023

To: Alfredo Garcia, Project Planner

From: Sabrina Chavez, Director of Community Services

Cc: Arcenio Ramirez, Assistant Director of Community Services
Arturo Garcia, Parks Manager
Joshua Estrada, Parks Coordinator

Subject: Development Plan Review 21-00018 – Proposed 37-unit residential development on vacant land and associated improvements. The site is comprised of 2 existing vacant parcels totaling 1.82 +/- acres. The downtown Specific Plan designated the project site as Urban Village – Comments

Community Services Staff reviewed DPR 21-00018 and offer the following comment(s):

Development Impact Fees

- The Project is subject to payment of Industrial Park Development Impact Fees.
- The Project is subject to payment of Residential Park Development Impact Fees.
- This Project is subject to payment of Public Art Development Impact Fees.

Special Districts

- The project shall annex into the Community Facilities District No. 2018-02 (Public Services)

SRC COMMENTS
***** BUILDING & SAFETY *****

Planning Case File No(s): DEVELOPMENT PLAN REVIEW #21-00018

Case Planner: Alfredo Garcia (951) 943-5003,

Applicant: Winston Liu

Location: Along G Street at the terminus of E 2nd street

Project: Proposed 37- unit residential development

APN(s): 310-070-001 and 002

Reviewed By: David J. Martinez, CBO

Date: 11-16-2021

BUILDING AND SAFETY CONDITIONS

1. Shall comply with the latest adopted State of California 2019 editions of the following codes as applicable:
 - A. 2019 California Building Code
 - B. 2019 Residential Code
 - C. 2019 California Electrical Code
 - D. 2019 California Mechanical Code
 - E. 2019 California Plumbing Code
 - F. 2019 California Energy Code.
 - G. 2019 California Fire Code
 - H. 2019 California Green Building Standards Code.
2. You will be required to provide proper fire access to the entire site.
3. The proposed lots will have to comply with the new EV charging station regulations.
4. You will have to comply with the Title 24 and ADA Access regulations for the complex facilities and the site.
5. You will have to comply with the Solar regulations for the residential units
6. No building will be allowed to be built over any parcel lines. The Parcel Map must be recorded prior to the issuance of any building permits

PRIOR TO ISSUANCE OF BUILDING/CONSTRUCTION PERMITS

1. The following items shall be completed and/or submitted as applicable – prior to the issuance of building permits for this project:
 - A. Precise grading plans shall be approved
 - B. Rough grading completed
 - C. Compaction certification
 - D. Pad elevation certification
 - E. Rough grade inspection signed off

FIRE CONDITIONS: To Be provided by Dennis Grubb

EXHIBIT B

Location / Aerial Map

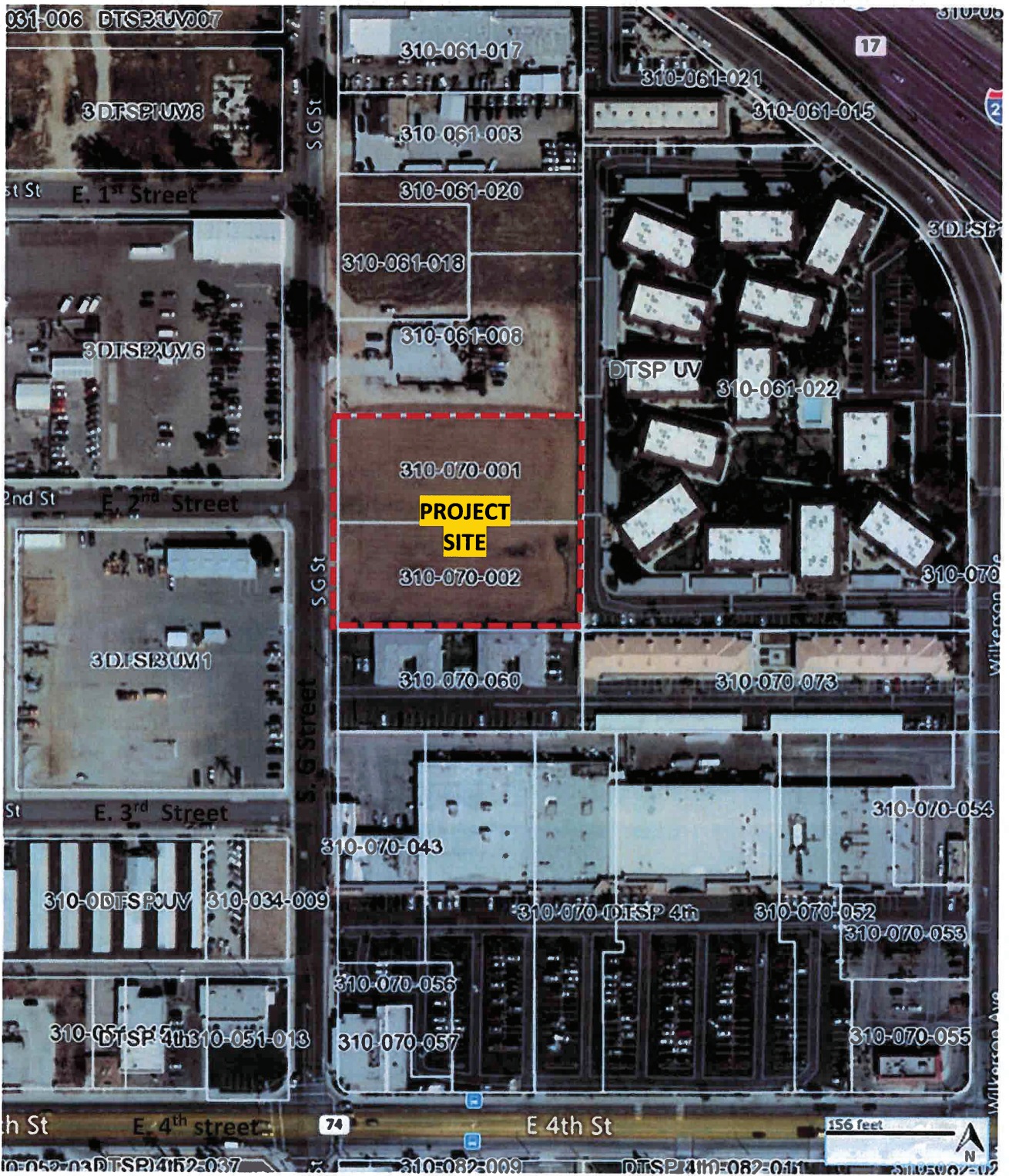

EXHIBIT C

Downtown Specific Plan Land Use Map

EXHIBIT D
Project Plans



WAM LAND DESIGN CONSULTANTS INC.
 175 S. 225 SOUTH G STREET, SUITE 200
 PERMIS, CA 92570
 TEL: (951) 241-1100
 FAX: (951) 241-1107

PROJECT: A 37-UNIT RESIDENTIAL (CONDO)
 DEVELOPMENT
 (DPR 21-00018)
 ADDRESS: 175 S. 225 SOUTH G STREET,
 PERMIS, CA 92570
 CLIENT: GRACE SU
 MEDGO REALTY GROUP, INC.
 12403 CENTRAL AVE., 6610
 CHINO, CA 91710

SHEET TITLE: PROPOSED SITE PLAN & REFERENCE NOTES
 SHEET NO.:
 SET MAP:
 SEAL/STAMP:
 JOB NO.:
 DRAWN BY:
 SUPERVISED BY:
 CHECKED BY:
 PLAN CHECK:
 PERMIT SET:
 REVISIONS:
 NO. DATE BY
 1 10/1/2021
 2 10/1/2021
 3 10/1/2021
 4 10/1/2021
 5 10/1/2021
 6 10/1/2021
 7 10/1/2021
 8 10/1/2021
 9 10/1/2021
 10 10/1/2021

A1.01
 OF SHEETS
 SCALE: 1" = 1'-0"

Reference Notes

- (E) PROPERTY LINES.
- (N) FENCE WALL, SEE 1-1.
- (N) FENCE WALL, SEE 1-1.
- TRASH ENCLOSURE W/ ROOF, SEE 1-1.
- HANDICAP PARKING.
- EV PARKING.
- TRANSFORMER PAD.
- DECORATION PAVING.
- 26'-0" WIDE FIRE LANE, SEE ALDZ FIRE ACCESS PLAN 1-1.
- (N) 4'-0" WIDE CONC. PAVED PATH OF TRAVEL FROM PUBLIC SIDEWALK TO PROPOSED BUILDING ENTRY AND TRASH ENCLOSURE, MAX. 3% SLOPE AND 2% CROSS SLOPE. SEE CIVIL PLAN.
- EXISTING WALL.
- MONUMENT SIGN, SEE 3-1.
- (E) FIRE HYDRANT, SEE CIVIL PLAN.
- ASPHALT PAVING, TP.
- (P) FIRE HYDRANT LOCATION.

Legend

- PATH OF TRAVEL
- LANDSCAPE AREA
- 26'-0" FIRE LANE
- PARKING COUNT
- FIRE HYDRANT

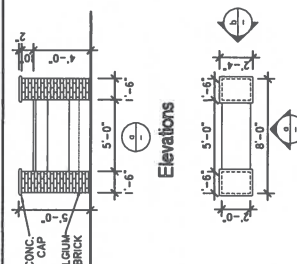

Project Data

APPLICABLE CODES:
 2019 IBC, SEC. 07, CMC, CPC, CALIFORNIA ENERGY CODE, CALIFORNIA ENERGY CODE, 175 S. 225 SOUTH G STREET, 310-070-001, 310-070-002, 79,201± S.F. (1.82± ACRE), 0139, V8, R-2 (RESIDENTIAL), YES (MFA 1), YES (MFA 7), 35'-0"

REQUIRED: PARKING PROVIDED:
 2-CAR PER UNIT (37 UNITS)
 3-BEDROOM (17 UNITS)
 2-CAR GARAGE
 2 SPACES
 2-CAR GARAGE
 2 SPACES

LOT SIZE (GROSS):
 79,201± S.F. (1.82± ACRE)
 LOT COVERAGE:
 31,403 S.F. / 79,201 S.F. = 39.65%
 LANDSCAPE PERCENTAGE:
 13,326 S.F. / 79,201 S.F. = 16.82%

EXISTING SINGLE FAMILY RESIDENCE
 APN: 310-061-008
 278'-5" x 300'-0"

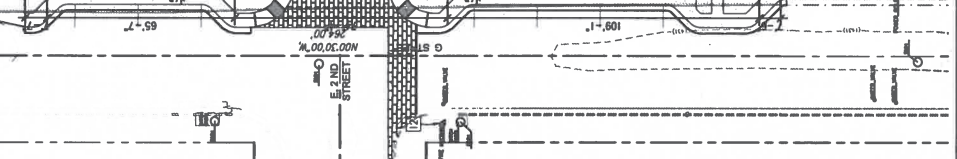
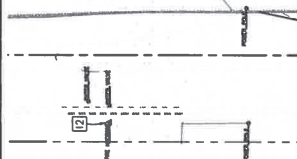
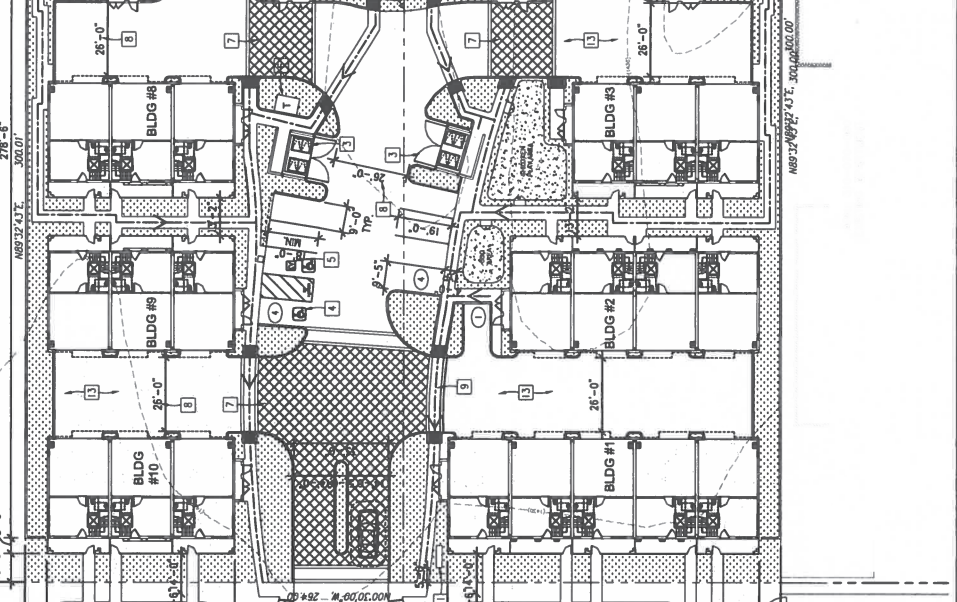
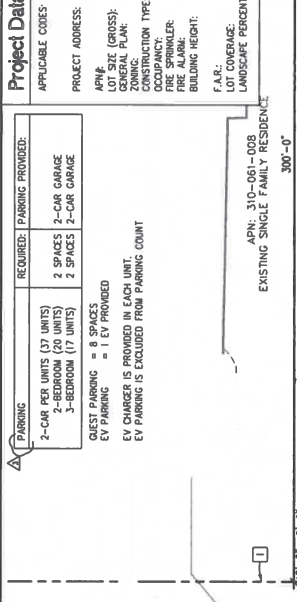
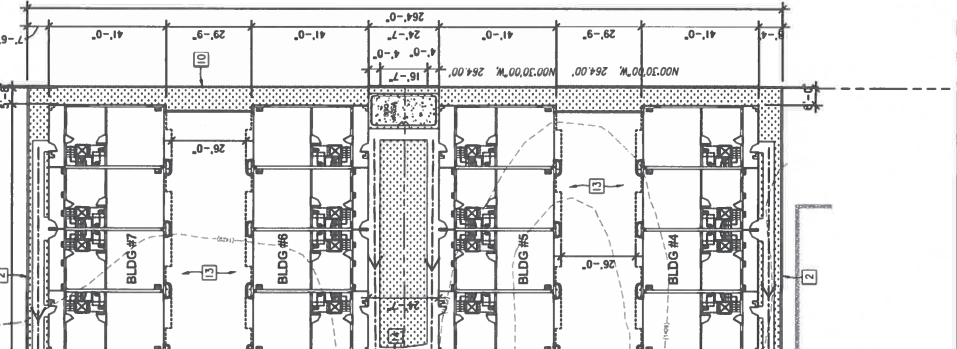
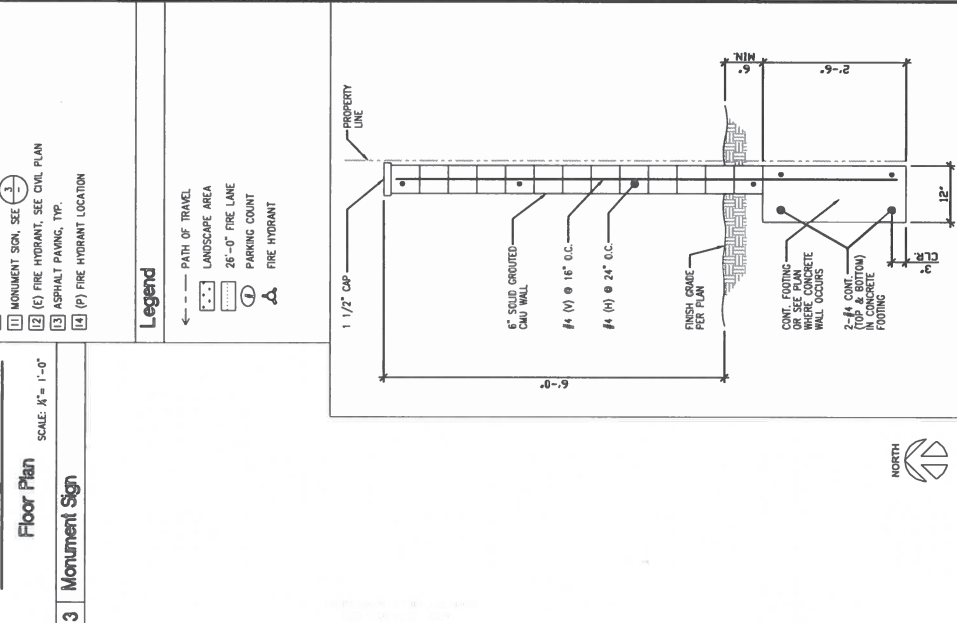

2 Proposed Site Plan
 SCALE: 1" = 20'-0"

1 CMU Fence Wall
 SCALE: 1" = 1'-0"

3 Monument Sign
 SCALE: 1" = 1'-0"

Reference Notes

- (E) PROPERTY LINES.
- (N) FENCE WALL, SEE 1-1.
- (N) FENCE WALL, SEE 1-1.
- TRASH ENCLOSURE W/ ROOF, SEE 1-1.
- HANDICAP PARKING.
- EV PARKING.
- TRANSFORMER PAD.
- DECORATION PAVING.
- 26'-0" WIDE FIRE LANE, SEE ALDZ FIRE ACCESS PLAN 1-1.
- (N) 4'-0" WIDE CONC. PAVED PATH OF TRAVEL FROM PUBLIC SIDEWALK TO PROPOSED BUILDING ENTRY AND TRASH ENCLOSURE, MAX. 3% SLOPE AND 2% CROSS SLOPE. SEE CIVIL PLAN.
- EXISTING WALL.
- MONUMENT SIGN, SEE 3-1.
- (E) FIRE HYDRANT, SEE CIVIL PLAN.
- ASPHALT PAVING, TP.
- (P) FIRE HYDRANT LOCATION.

Legend

- PATH OF TRAVEL
- LANDSCAPE AREA
- 26'-0" FIRE LANE
- PARKING COUNT
- FIRE HYDRANT

SCALE: 1" = 20'-0"
 SCALE: 1" = 1'-0"



WAW LAND DESIGN CONSULTANTS INC.
 ARCHITECTURE, CIVIL ENGINEERING & INTERIOR DESIGN
 2345 W. GARDEN BLVD., STE. L, LAKELAND, CA 92656
 PHONE: (800) 688-7718 FAX: (800) 954-1377

PROJECT: A 27-UNIT RESIDENTIAL (CONDO) DEVELOPMENT
ADDRESS: 175 S 225 SOUTH G STREET, PERRIS, CA 92570
CLIENT: GRACE SU METRO CENTRAL AVE #910 CHINO, CA 91710



REVISIONS

NO.	DATE	BY	DESCRIPTION
1	11/11/18	WAW	ISSUE FOR PERMITS
2	11/11/18	WAW	ISSUE FOR PERMITS
3	11/11/18	WAW	ISSUE FOR PERMITS
4	11/11/18	WAW	ISSUE FOR PERMITS
5	11/11/18	WAW	ISSUE FOR PERMITS
6	11/11/18	WAW	ISSUE FOR PERMITS
7	11/11/18	WAW	ISSUE FOR PERMITS
8	11/11/18	WAW	ISSUE FOR PERMITS
9	11/11/18	WAW	ISSUE FOR PERMITS
10	11/11/18	WAW	ISSUE FOR PERMITS

TRASH ENCLOSURE & DETAILS

SHEET TITLE: TRASH ENCLOSURE & DETAILS

A1.11

OF SHEETS

Reference Notes

- 1 ROOF ABOVE
- 2 1/2" CDX PLYWOOD W/ 8D COMMON NAILS, 6" O.C. EDGES, 12" O.C. A FIELD W/ CLASS A ROOFING
- 3 DASH LINE INDICATE CHU WALL BE ON.

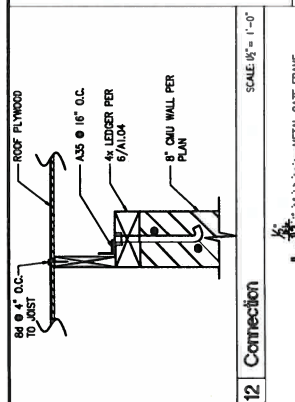
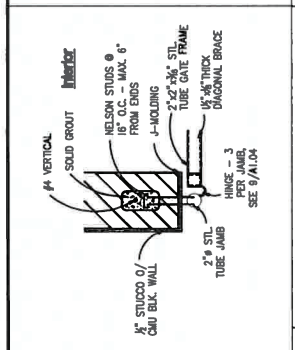
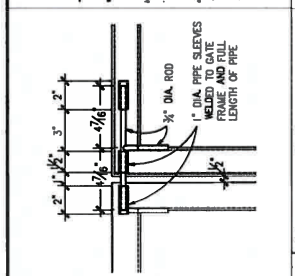
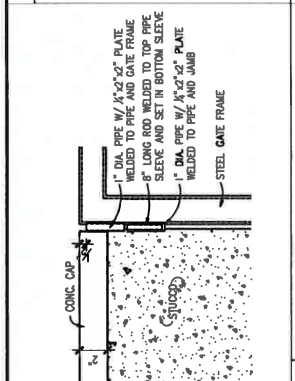

Key Notes

- 1 6\"/>

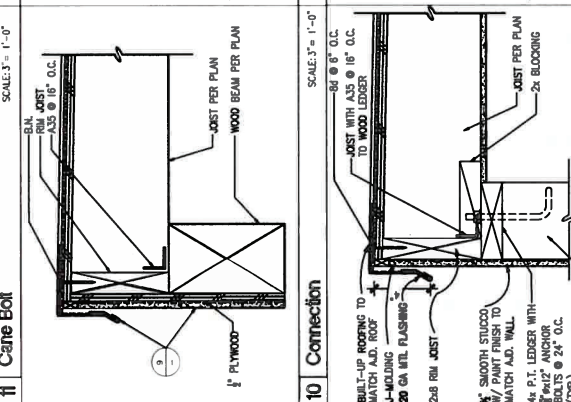
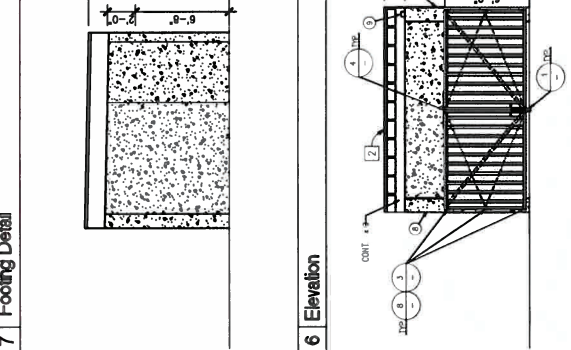
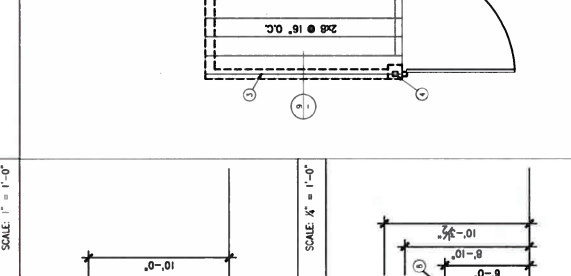
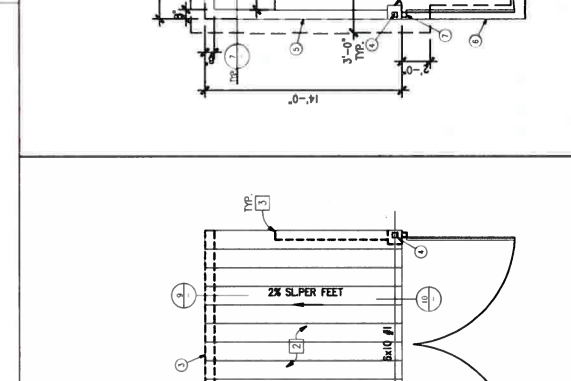
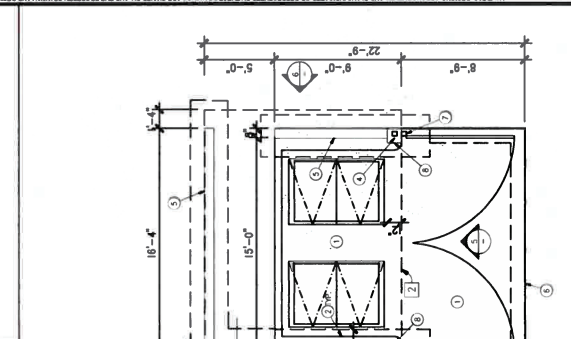
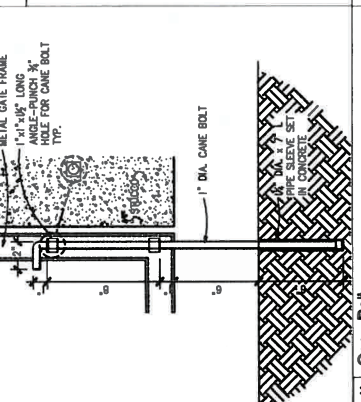
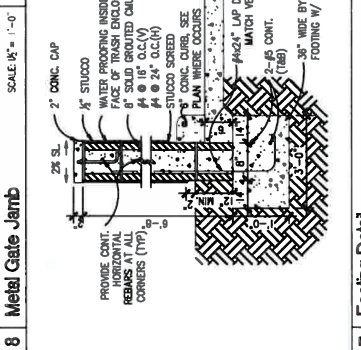
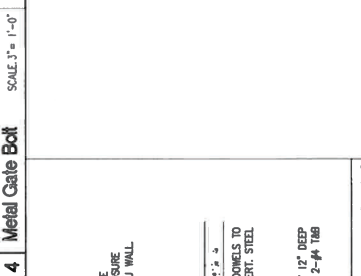

SCALE: 3/4\"/>

SCALE: 3/4\"/>

SCALE: 1\"/>

SCALE: 1/4\"/>

SCALE: 3/4\"/>

Reference Notes

- 1 CLASS 'A' ULTRAVIOLET (ULTRAVIOLET POLYOLEFIN) SINGLE-PLY ROOFING MEMBRANE BY PRESTONE BUILDING PRODUCTS COMPANY, INC. (E81-253)
- 2 30" x 30" x 0.5" CONCRETE SLAB ON GRADE
- 3 YEAR SOLAR REFLECTANCE: 0.79
- 4 YEAR THERMAL ENTRANCE: 0.83
- 5 YEAR U-VALUE: 0.08
- 6 YEAR U-VALUE: 0.08
- 7 NOT USE
- 8 ROOF DRAIN AND OVERFLOW OUTLET
- 9 30" x 30" SQ. ROOF HATCH BY BUCO OR APPROVED EQUAL
- 10 A/C UNIT & EQUIPMENT PLATFORM

11 PROPOSED SOLAR ZONE (MIN. 15%)
 TOTAL ROOF AREA = 3,943 SF
 REQUIRED SOLAR ZONE (MIN. 15%)
 PROPOSED SOLAR ZONE = 640 SF
 PARAPET BRACING, SEE STRL. PLAN.

General Notes

- 1. ALL WALL DIMENSIONS ARE FROM F.A.S., UNLESS NOTED OTHERWISE.
- 2. ALL WINDOW AND DOOR DIMENSIONS ARE FROM CENTER LINE OF THE WINDOW OR DOOR.
- 3. PROVIDE R-13 INSULATION @ ALL PLUMBING WELLS.

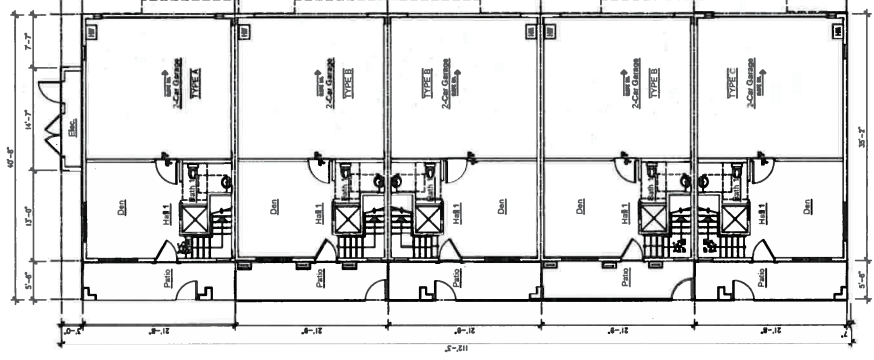
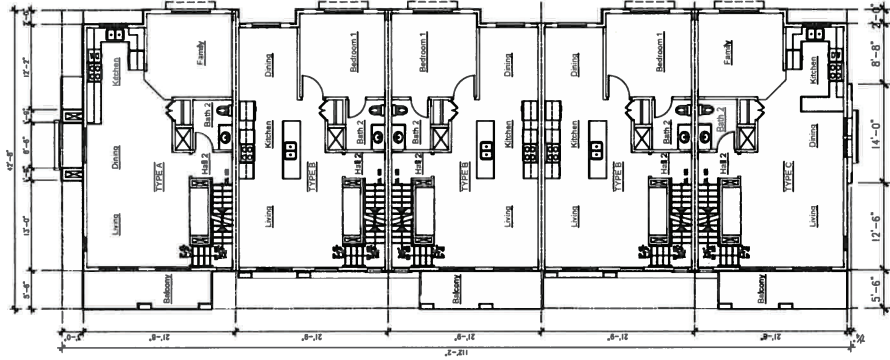
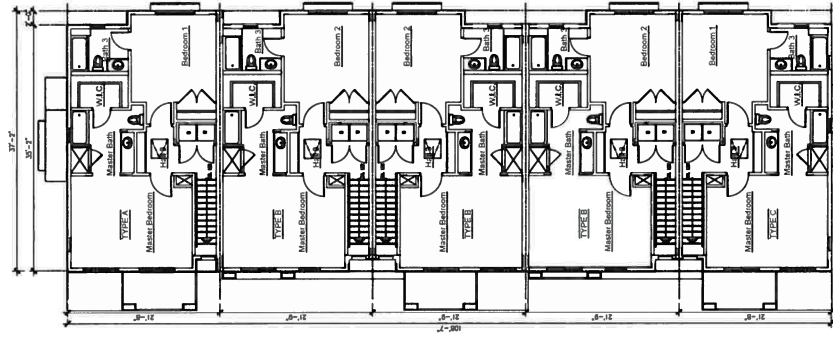
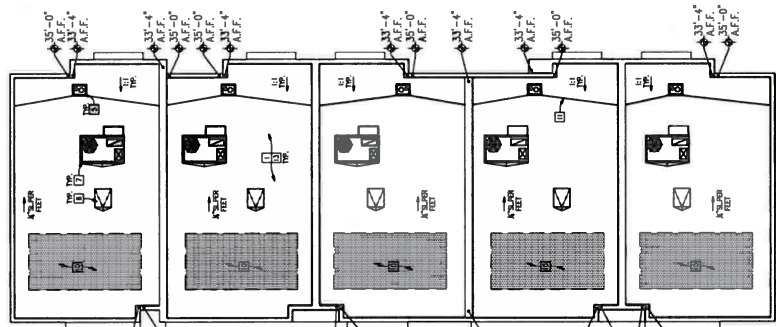



WILMINGTON CONSULTANTS INC.
 ARCHITECTURE, ONE ENGINEERING & INTERIOR
 12409 CENTRAL AVE., #510
 CHINO, CA 91710
 PHONE: (909) 699-7110 FAX: (909) 696-1110

PROPOSED FLOOR PLAN
BUILDING #1

PROJECT: A 37-UNIT RESIDENTIAL (CONDO) DEVELOPMENT (DPR 21-00018)
 ADDRESS: 175 S 225 SOUTH G STREET, PERRIS, CA 92570
 CLIENT: GRACE SU
 MEGUIO REALTY GROUP, INC.
 12409 CENTRAL AVE., #510
 CHINO, CA 91710

SHEET TITLE: PROPOSED FLOOR PLAN
 SERIAL STAMP: [Stamp]

JOB NO. 2104MR
 DRAWN BY: AZ/L
 CHECKED BY: TL
 DATE: 05/01/2021
 DATE: 05/01/2021
 DATE: 05/01/2021
 DATE: 05/01/2021

REVISIONS

NO.	DATE	DESCRIPTION
1	05/01/2021	ISSUE FOR PERMITS
2	05/01/2021	ISSUE FOR PERMITS
3	05/01/2021	ISSUE FOR PERMITS

Colors & Materials

- 1 ARTISAN SHIP LAP SONG BY JAMES HARDIE
W/ PAINT FINISH
- 2 STONE BY CORONADO STONE
STYLE: ROMAN BRICK, COLOR: SPRAWO
- 3 LAHABRA STUCCO W/ PAINT FINISH OR EQ.
SANTA BARBARA MISSION FINISH
COLOR: DUNN EDWARDS, DET1455 COPPER MINING
- 4 LAHABRA STUCCO W/ PAINT FINISH OR EQ.
SANTA BARBARA MISSION FINISH
COLOR: DUNN EDWARDS, DET1880 ESPRESSO MACCHIATO
- 5 NOT IN USE
- 6 LAHABRA STUCCO W/ PAINT FINISH OR EQ.
SANTA BARBARA MISSION FINISH
COLOR: DUNN EDWARDS, DET1848 WHITE PICKET FENCE
- 7 FOAM MOULDING W/ PAINT FINISH
COLOR: DUNN EDWARDS, DET1848 WHITE PICKET FENCE
- 8 WYAL WINDOW BY MILGARD - DUAL GLAZING,
COLOR: WHITE
- 9 WYAL SLIDING DOOR BY MILGARD - DUAL GLAZING,
COLOR: WHITE
- 10 STAINLESS STEEL CABLE RAILING
- 11 ENTRY DOOR W/ PAINT FINISH,
COLOR: DUNN EDWARDS, DET1880 ESPRESSO MACCHIATO
- 12 SANTA BARBARA MISSION FINISH
COLOR: DUNN EDWARDS, DET1848 WHITE PICKET FENCE
- 13 EXTERIOR LED WALL LIGHTING,
KICHLER, WALDEN 12" LED WALL LIGHT TEXTURED BLACK
POSSIBLE LIGHT FIXTURES: BLACK OUTDOOR
LED WALL UP AND DOWNLIGHT
- 14 GARAGE DOOR
COLOR: DUNN EDWARDS, DET1880 ESPRESSO MACCHIATO
- 15 DOOR W/ PAINT FINISH,
COLOR: DUNN EDWARDS, DET1880 ESPRESSO MACCHIATO
- 16 EXTERIOR LED WALL LIGHTING,
KICHLER, WALDEN 12" LED WALL LIGHT TEXTURED BLACK
POSSIBLE LIGHT FIXTURES: BLACK OUTDOOR
LED WALL UP AND DOWNLIGHT
- 17 EXTERIOR LED WALL LIGHTING,
KICHLER, WALDEN 12" LED WALL LIGHT TEXTURED BLACK
POSSIBLE LIGHT FIXTURES: BLACK OUTDOOR
LED WALL UP AND DOWNLIGHT
- 18 EXTERIOR LED WALL LIGHTING,
KICHLER, WALDEN 12" LED WALL LIGHT TEXTURED BLACK
POSSIBLE LIGHT FIXTURES: BLACK OUTDOOR
LED WALL UP AND DOWNLIGHT

Color Legend

- 1 ARTISAN SHIP LAP SONG BY JAMES HARDIE
W/ PAINT FINISH
COLOR: DUNN EDWARDS, DET1827 FEWTER PATTER
- 2 STONE BY CORONADO STONE
STYLE: ROMAN BRICK, COLOR: SPRAWO
- 3 EXTERIOR SMOOTH STUCCO W/ PAINTED FINISH,
COLOR: DUNN EDWARDS, DET1455 COPPER MINING
- 4 EXTERIOR SMOOTH STUCCO W/ PAINTED FINISH,
COLOR: DUNN EDWARDS, DET1880 ESPRESSO MACCHIATO
- 5 EXTERIOR SMOOTH STUCCO W/ PAINTED FINISH,
COLOR: DUNN EDWARDS, DET216 BARREL STONE
- 6 EXTERIOR STUCCO W/ PAINTED FINISH,
COLOR: DUNN EDWARDS, DET1848 WHITE PICKET FENCE



3 Elevation C



4 Elevation D



1 Elevation A



2 Elevation B



WENT LAND DESIGN CONSULTANTS INC.
ARCHITECTURE, ONE DIMENSION & BIRDSONG
2335 N. FORTUNA BLVD., STE. 1, LIPAWA, CA 91706
(909) 609-7115 FAX: (909) 746-1121

PROJECT: A 37-UNIT RESIDENTIAL (CONDO)
DEVELOPMENT
(C/P# 21-50018)
ADDRESS: 175 & 225 SOUTH G STREET,
PERFINS, CA 92570
CLIENT: GRACE SU
HORIZON REALTY GROUP, INC.
CHINO, CA 91710

BUILD #1
ELEVATIONS



DATE: 09/17/2021
BY: [Signature]
CHECKED BY: [Signature]
SUPERSEDED BY: [Signature]
JOB NO.: [Number]
JOB NAME: [Name]

REVISIONS

NO.	DATE	DESCRIPTION
1	09/17/2021	ISSUE FOR PERMIT SET
2	09/17/2021	ISSUE FOR PERMIT SET

A3.01
OF SHEETS
S H E E T

Colors & Materials

- 1 ARTISAN SHIPLAP SIDING BY JAMES HARDE W/ PAINT FINISH
COLOR: DUNN EDWARDS, DETB27 PEWTER PATTER
- 2 STONE BY CORONADO STONE
STYLE: ROMAN BROCK, COLOR: SOPRANO
- 3 LAHABRA STUCCO W/ PAINT FINISH OR EQ.
COLOR: DUNN EDWARDS, DETH45 COPPER MINING
SANTA BARBARA MISSION FINISH
- 4 LAHABRA STUCCO W/ PAINT FINISH OR EQ.
COLOR: DUNN EDWARDS, DETB80 ESPRESSO MACCHIATO
- 5 LAHABRA STUCCO W/ PAINT FINISH OR EQ.
COLOR: DUNN EDWARDS, DETB80 ESPRESSO MACCHIATO
- 6 ENTRY DOOR W/ PAINT FINISH,
SANTA BARBARA MISSION FINISH
COLOR: DUNN EDWARDS, DETB16 BARREL STONE
- 7 NOT IN USE
- 8 LAHABRA STUCCO W/ PAINT FINISH OR EQ.
COLOR: DUNN EDWARDS, DETB48 WHITE PICKET FENCE
- 9 FOAM MOLDING W/ PAINT FINISH
COLOR: DUNN EDWARDS, DETB48 WHITE PICKET FENCE
- 10 VINYL WINDOW BY MILGARD - DUAL GLAZING,
COLOR: WHITE
- 11 VINYL SLIDING DOOR BY MILGARD - DUAL GLAZING,
COLOR: WHITE
- 12 STAINLESS STEEL CABLE RAILING
- 13 LAHABRA STUCCO W/ PAINT FINISH,
SANTA BARBARA MISSION FINISH
COLOR: DUNN EDWARDS, DETB80 ESPRESSO MACCHIATO

- 14 GARAGE DOOR
COLOR: DUNN EDWARDS, DETB80 ESPRESSO MACCHIATO
- 15 DOOR W/ PAINT FINISH
COLOR: DUNN EDWARDS, DETB27 PEWTER PATTER
- 16 EXTERIOR LED WALL LIGHTING,
KICHLER, WALDEN 12" LED WALL LIGHT TEXTURED BLACK
- 17 EXTERIOR LED WALL LIGHTING,
POSSINI LIGHTING, STANFORD BLACK OUTDOOR
LED WALL UP AND DOWNLIGHT

Color Legend

- ARTISAN SHIPLAP SIDING BY JAMES HARDE W/ PAINT FINISH
COLOR: DUNN EDWARDS, DETB27 PEWTER PATTER 1
- STONE BY CORONADO STONE
STYLE: ROMAN BROCK
COLOR: SOPRANO 2
- EXTERIOR SMOOTH STUCCO W/ PAINTED FINISH,
COLOR: DUNN EDWARDS, DETH45 COPPER MINING 3
- EXTERIOR SMOOTH STUCCO W/ PAINTED FINISH,
COLOR: DUNN EDWARDS, DETB80 ESPRESSO MACCHIATO 4
- EXTERIOR SMOOTH STUCCO W/ PAINTED FINISH,
COLOR: DUNN EDWARDS, DETB16 BARREL STONE 5
- EXTERIOR SMOOTH STUCCO W/ PAINTED FINISH,
COLOR: DUNN EDWARDS, DETB48 WHITE PICKET FENCE 6

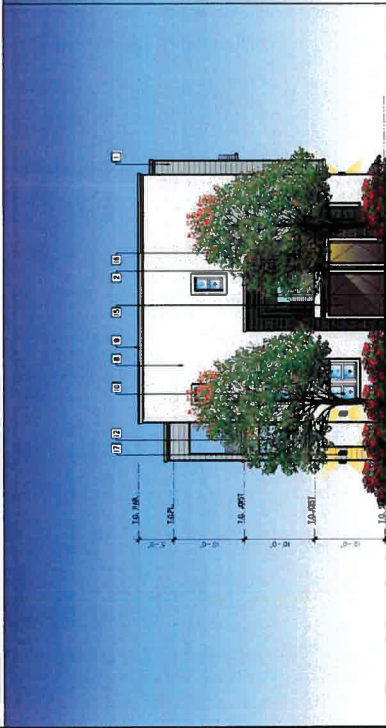

3 Elevation C



4 Elevation D

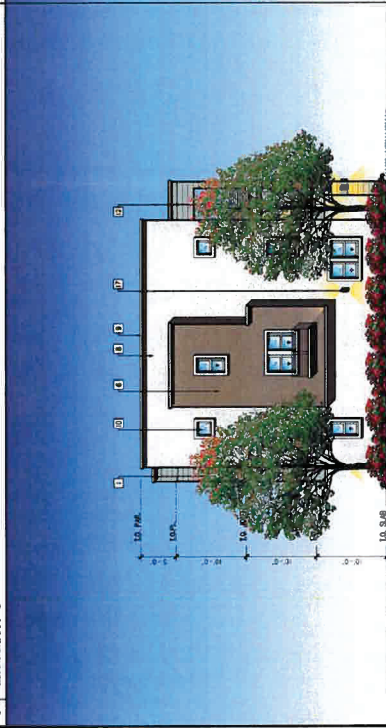

1 Elevation A



2 Elevation B

W
ARCHITECTURE
175 S. GARDEN BLVD, STE 300, UPLAND, CA 91786
TEL: (909) 966-7110 FAX: (909) 966-1137

PROJECT: A 37-UNIT RESIDENTIAL (CONDO)
DEVELOPMENT
(DPR 21-00018)
ADDRESS: 175 S 225 SOUTH G STREET,
PERRIS, CA 92570
CLIENT: GRACE SU
MEDGO CENTRAL AVE., #610
CHINO, CA 91710

SHEET TITLE: ELEVATIONS
(BUILDING #3, #9 REVERSED)
KEY MAP: [Map showing project location in Perris, CA]

DESIGNED BY: [Firm Name]
DRAWN BY: [Firm Name]
CHECKED BY: [Firm Name]
DATE: 07/27/2023

REVISIONS

NO.	DATE	DESCRIPTION
1	07/27/2023	ISSUE FOR PERMIT
2	07/27/2023	ISSUE FOR PERMIT
3	07/27/2023	ISSUE FOR PERMIT
4	07/27/2023	ISSUE FOR PERMIT
5	07/27/2023	ISSUE FOR PERMIT
6	07/27/2023	ISSUE FOR PERMIT
7	07/27/2023	ISSUE FOR PERMIT
8	07/27/2023	ISSUE FOR PERMIT
9	07/27/2023	ISSUE FOR PERMIT
10	07/27/2023	ISSUE FOR PERMIT

A3.02
OF SHEETS
SCALE: 1/8"=1'-0"

Colors & Materials

- 1 ARTISAN SHIP LAP SIDING BY JAMES HARDIE W/ PAINT FINISH
COLOR: DUNN EDWARDS, DET1627 FEWFER PATTER
- 2 STONE BY CORONADO STONE
STYLE: ROMAN BRICK, COLOR: SORANO
- 3 LAHABRA STUCCO W/ PAINT FINISH OR EQ.
SANTA BARBARA MISSION FINISH
COLOR: DUNN EDWARDS, DET1455 COPPER MIRROR
- 4 LAHABRA STUCCO W/ PAINT FINISH OR EQ.
SANTA BARBARA MISSION FINISH
COLOR: DUNN EDWARDS, DET1680 ESPRESSO MACCHIATO
- 5 NOT IN USE
- 6 LAHABRA STUCCO W/ PAINT FINISH OR EQ.
SANTA BARBARA MISSION FINISH
COLOR: DUNN EDWARDS, DET1648 WHITE PICKET FENCE
- 7 FOAM MOLDING W/ PAINT FINISH
COLOR: DUNN EDWARDS, DET1648 WHITE PICKET FENCE
- 8 VINYL WINDOW BY MILGARD - DUAL GLAZING,
COLOR: WHITE
- 9 VINYL SLIDING DOOR BY MILGARD - DUAL GLAZING,
COLOR: WHITE
- 10 STAINLESS STEEL CABLE RAILING
- 11 ENTRY DOOR W/ PAINT FINISH,
COLOR: DUNN EDWARDS, DET1680 ESPRESSO MACCHIATO
- 12 LAHABRA STUCCO W/ PAINT FINISH OR EQ.
SANTA BARBARA MISSION FINISH
COLOR: DUNN EDWARDS, DET1627 FEWFER PATTER
- 13 STONE BY CORONADO STONE
STYLE: ROMAN BRICK, COLOR: SORANO
- 14 EXTERIOR LED WALL LIGHTING,
KICHLER, WALDEN 12" LED WALL LIGHT TEXTURED BLACK
POSSIBLE LIGHTING: STANFORD, BLACK OUTDOOR
LED WALL UP AND DOWNLIGHT
- 15 GARAGE DOOR
COLOR: DUNN EDWARDS, DET1680 ESPRESSO MACCHIATO
- 16 DOOR W/ PAINT FINISH,
COLOR: DUNN EDWARDS, DET1680 ESPRESSO MACCHIATO
- 17 EXTERIOR SMOOTH STUCCO W/ PAINT FINISH,
COLOR: DUNN EDWARDS, DET1680 ESPRESSO MACCHIATO
- 18 EXTERIOR SMOOTH STUCCO W/ PAINT FINISH,
COLOR: DUNN EDWARDS, DET1648 WHITE PICKET FENCE
- 19 EXTERIOR SMOOTH STUCCO W/ PAINT FINISH,
COLOR: DUNN EDWARDS, DET1455 COPPER MIRROR
- 20 EXTERIOR SMOOTH STUCCO W/ PAINT FINISH,
COLOR: DUNN EDWARDS, DET1680 ESPRESSO MACCHIATO

Color Legend

- ARTISAN SHIP LAP SIDING BY JAMES HARDIE W/ PAINT FINISH
COLOR: DUNN EDWARDS, DET1627 FEWFER PATTER
- STONE BY CORONADO STONE
STYLE: ROMAN BRICK, COLOR: SORANO
- EXTERIOR SMOOTH STUCCO W/ PAINT FINISH,
COLOR: DUNN EDWARDS, DET1455 COPPER MIRROR
- EXTERIOR SMOOTH STUCCO W/ PAINT FINISH,
COLOR: DUNN EDWARDS, DET1680 ESPRESSO MACCHIATO
- EXTERIOR SMOOTH STUCCO W/ PAINT FINISH,
COLOR: DUNN EDWARDS, DET1648 WHITE PICKET FENCE



3 Elevation C



4 Elevation D



1 Elevation A



2 Elevation B

SCALE: 1/8"=1'-0"

NEW LAND DESIGN CONSULTANTS INC.
ARCHITECTURE, CIVIL, LANDSCAPE & INTERIOR
2335 W. FORTMILL BLVD., STE. 1, UPLAND, CA 91786
(909) 939-7118 FAX: (909) 946-1127

PROJECT: A 37-UNIT RESIDENTIAL (CONDO)
DEVELOPMENT
(DPR 21-00018)
ADDRESS: 175 & 225 SOUTH G STREET,
PERRIS, CA 92570
CLIENT: GRACE SU
1209 CENTRAL AVE., #810
CHINO, CA 91710

SHEET TITLE:
ELEVATIONS
BUILDING #2, #5, & #7
(BUILDING #4, #6 REVERSED)



JOB NO. _____
DATE: _____
SUPERSEDED BY: _____
CHECKED BY: _____
PLAN CHECK: _____
PERMIT SET: _____
BID SET: _____
DATE: _____

REVISIONS

NO.	DATE	DESCRIPTION

A3.03
OF SHEETS
S H E E T

REVISIONS	BY



**PHIL MAY
LANDSCAPE
ARCHITECTURE**
2522 Wilshire Ave.
Fulerton, CA 92831
Phone: 909 373 1199
www.philmaydesign.com



PLANTING PLAN

**37-UNIT RESIDENTIAL CONDO
DEVELOPMENT
175&225 SOUTH G ST.
PERRIS, CA 92570**

DRAWN
CHECKED
DATE
04/16/22
SHEET

L-2
OF 3 SHEETS
JOB NO.
21123



PLANT LEGEND

SYMBOL	BOTANICAL NAME	COMMON NAME
	TREES	
	<i>Arbutus 'Marino'</i>	
	<i>Geijera parvifolia</i>	
	<i>Lagostroemia l. 'Tuscarora'</i>	
	<i>Lophostemon confertus</i>	
	<i>Chitalpa laskhentensis</i>	
	SHRUBS	
	<i>Agave attenuata</i>	
	<i>Callistemon 'Little John'</i>	
	<i>Ligustrum j. 'Texanum'</i>	
	<i>Salvia g. 'Novajo Bright Red'</i>	
	<i>Westringia fruticosa 'Smoky'</i>	
	<i>Westringia fruticosa 'Mundi'</i>	
	<i>Grevillea 'Noelle'</i>	
	PERENNIALS	
	<i>Aloe striata</i>	
	<i>Dianella revoluta 'Little Rev'</i>	
	<i>Dianella l. 'Variegata'</i>	
	<i>Bubline frutescens 'Orange'</i>	
	<i>Diets indioides 'Orange Drop'</i>	
	<i>Kniphofia uvaria</i>	
	GROUNDCOVER	
	<i>Rosmarinus o. 'Hunt. Carpet'</i>	
	<i>Festuca arundinacea</i>	
	<i>Myoporum panicifolium</i>	
	Children play area	

